

# Wind & Energy Systems

## Master thesis and Bachelor project Topic Catalogue

### 2025/2026

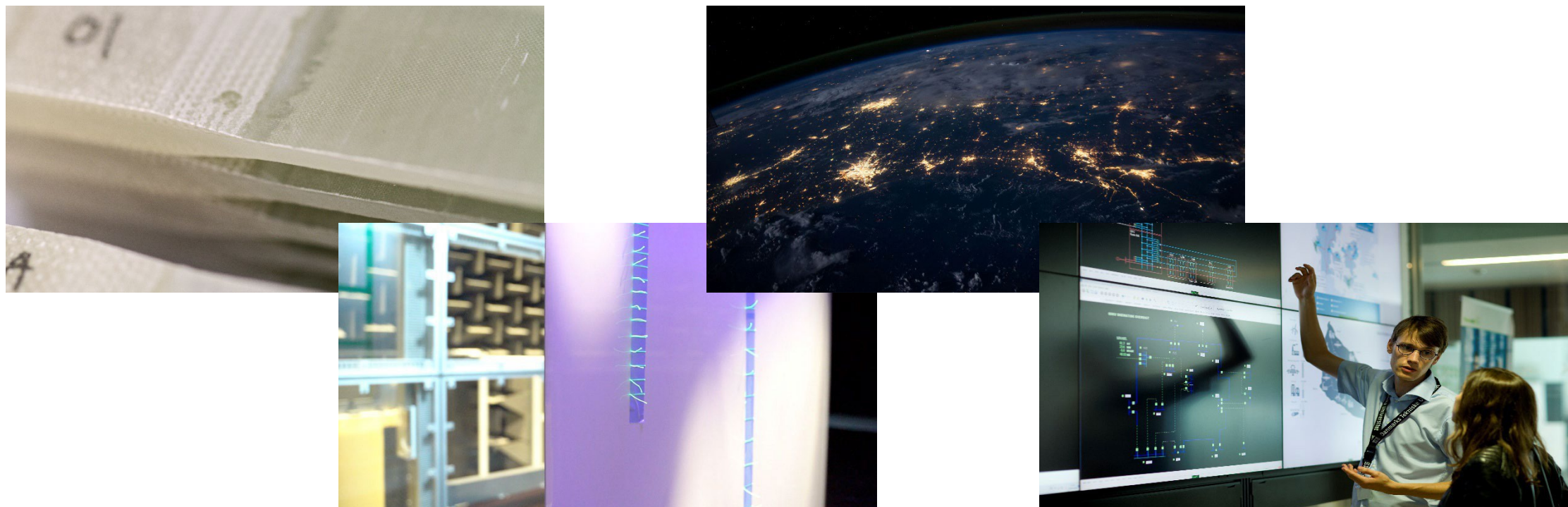

# Master thesis & Bachelor projects topic catalogue for 2025/2025

In this catalogue you can find different topics within Wind and Energy Systems. You are of course also welcome to be inspired in creating your own topic, based on ideas you find here.

All topics are based on a 30 ECTS master thesis and 15 ECTS bachelor project – but some of them might be duable for a larger ECTS point.

You also find a number of topics from some of our Industrial partners – please keep in mind that a supervisor from DTU WIND must be your main supervisor.

We are looking forward to work with you in your thesis or project writing.

Below you see some colored bubbles. You will find a bubble on every topic page, they each indicate if the topic is a Master thesis, Bachelor project or can be both.

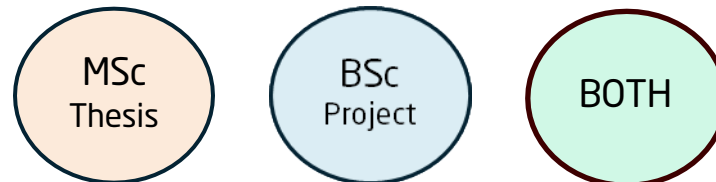

## Division for Power and Energy Systems (PES)

	<b>10</b>	
ABS study and development based on electro-valves and pump	Nenad Mijatovic	11 PES
Aggregating thermal energy storages for energy flexibility	Aneesh Nunna; Yi Zong	12 PES
ANN driven control of drives with sinusoidal filters	Miguel Lopez	13 PES
Behavioral Insights into EV User Providing in Flexibility Services	Tilman Weckesser, Haris Ziras	14 PES
BESS as flexibility platform	Shi You	15 PES
Black start from BESS	Shi You	16 PES
Charging behaviour of electric vehicles	Jan Engelhardt	17 PES
Comparison of System Stability between IBRs with grid forming vs. grid following inverters	Nenad Mijatovic	18 PES
Conditional connection agreements for transformer congestion reduction: a large-scale analysis for the Copenhagen area	Mattia Secchi	19 PES
Converter induced transformer diagnostics	Nenad Mijatovic	20 PES
Coupled degradation-LCA for V2G systems	Leonardo Ferhati	21 PES
Data-driven physics informed modelling of PCM TES	Aneesh Nunna; Yi Zong	22 PES
Detection of EV charging in a large residential smart meters dataset	Mattia Secchi	23 PES
Development of EV smart charger	Jan Engelhardt	24 PES
Digitalization value assessment for smart meter data	Kai Heussen	25 PES
Energy Coordination in Residential Neighborhoods	Jan Engelhardt	26 PES
Energy Management for Offshore-Wind-Hydrogen Systems	Aneesh Nunna; Yi Zong	27 PES
Enhancing Grid Resilience through Next-Generation Battery Storage	Chunyang Zhao, Chresten Traeholt	28 PES
Entity-driven consumer profiles generation	Kai Heussen	29 PES
EV charger Dynamic Model for Power System Stability	Tilman Weckesser	30 PES
Evaluating Economic Trade-offs in Flexible EV Charging Management	Haris Ziras, Margarita Chatzouli	31 PES
Evaluating the Identification of Residential EV Chargers Across Different Data Environments	Bjarke Bak	32 PES
Eventure BlueDot / Vermilion Racing Project Design requirements for integrating hub motors in Vermilion: Hub Motors development racer	Nenad Mijatovic	33 PES
Eventure BlueDot / Vermilion Racing Project Lap time simulation modelling	Nenad Mijatovic	34 PES
Eventure BlueDot / Vermilion Racing Project Servo Drive Steering System for Precision Vehicle Control	Nenad Mijatovic	35 PES
Eventure BlueDot / Vermilion Racing Project: Battery Management System (BMS) development	Nenad Mijatovic	36 PES
Eventure BlueDot / Vermilion Racing Project: Super-Cap storage system investigation	Nenad Mijatovic	37 PES
Eventure BlueDot / Vermilion Racing Project: Vermilion racer accumulator design	Nenad Mijatovic	38 PES
EVs as price makers in multiple electricity markets	Mathias Botoft Hansen	39 PES

Extreme Usage and Operational Conditions of Lithium-Ion Batteries Across Multi-Sector Applications	Chunyang Zhao, Chresten Traeholt	40	PES
Fast High Temperature Superconductive cable joint	Nenad Mijatovic	41	PES
Flexibility Assessment of Electrification in Cement Production	Bruno Laurini, Yi Zong	42	PES
Flexibility quantification of energy assets with Bayesian models	Pere Izquierdo	43	PES
Frequency support via residential bidirectional EV chargers: a large-scale analysis for a Danish aggregator	Mattia Secchi	44	PES
Hybrid PtX & Batteries in power systems	Shi You	45	PES
Impact of grounding of Y-Transformers in Offshore Substations on Asymmetrical LVRT and Post-Fault Overvoltage Behavior	Nenad Mijatovic	46	PES
Impact of running forecasting on EV scheduling	Mathias Botoft Hansen	47	PES
Investigation of Heterogeneous Behaviour of Second-Life Lithium-Ion Battery Systems	Chunyang Zhao, Chresten Traeholt	48	PES
Modeling of EV smart charging cluster	Jan Engelhardt	49	PES
Modelling residential electricity consumption – assessing modelling choices and data availability	Bjarke Bak	50	PES
New battery concepts and chemistries	Shi You	51	PES
Optimal phase allocation of electrification loads given per-phase smart meter data	Kai Heussen	52	PES
Over-current properties of a High Temperature Superconductive cable	Nenad Mijatovic	53	PES
Performance Evaluation of Aggregated EV Chargers for Ancillary Grid Services	Tilman Weckesser, Haris Ziras	54	PES
Power cables and joints AC resistance measurement methodology with thermal cycling	Nenad Mijatovic	55	PES
Power cables joints optimization of coating thickness and contact plate	Nenad Mijatovic	56	PES
Predicting frequency reserves with conformal prediction	Licio Romao	57	PES
Real-time frequency control using MPC	Licio Romao and Tilman Wecksser	58	PES
Robust state observers for sensor reduction in drives with sinusoidal filters	Miguel Lopez	59	PES
RTDS PowerLab Power Hardwer in Loop experimental setup for testing grid forming converters	Nenad Mijatovic	60	PES
Sensitivity Study of LVRT with Symmetrical Reactive Current Injection: Impact of Export Cable Length	Nenad Mijatovic	61	PES
Short Circuit High Power Laboratory Characterization	Nenad Mijatovic	62	PES
Study of Anti-lock Braking (ABS) System Using Additive Manufacturing and Standard Components suitable for FS	Nenad Mijatovic	63	PES
User-oriented Smart Meter Data Value Creation	Kai Heussen	64	PES
Zero inertia power systems	Shi You	65	PES
<b>Division for Wind Energy Systems (WES)</b>		<b>66</b>	
A spatial model for social acceptance	Matt Shields	67	WES
Airborne Wind Energy as a Sensor	Michael K. McWilliam	68	WES

Analyzing the Impact of Price Variability on Wind Power Revenues	Matti Koivisto, Rujie Zhu	69	WES
Assessing the Impact of Weather Variability on the Profitability of Wind Investments	Matti Koivisto	70	WES
Assessing the impact of wind direction variability on the modelling the wake characteristics	Alfredo Peña, Nikolas Angelou	71	WES
Benchmarking and hybridization of search and evolutionary algorithms for wind farm layout optimization	Ju Feng	72	WES
Black Start Capability in Renewable-Dominated Markets	Zeenat Hameed, Chresten Træholt,		WES
	Zoltan Pinter	73	
Buoyancy in Turbulence modelling via RDT	Mark Kelly, J. Mann, G. Larsen	74	WES
Comparative Modelling of Ancillary Service Markets in High-Renewable Power Systems	Zeenat Hameed, Chresten Træholt,		WES
	Zoltan Pinter	75	
Comparison of flow predictions between static and dynamic wake models	Vasilis Pettas, Julia Steiner	76	WES
Complex terrain: replacing RIX with effective roughness	Mark Kelly	77	WES
Depth of the ABL: modeled vs. measured	Mark Kelly	78	WES
Design of hybrid power plants consisting of wind, solar with multiple storage options	Megha Gupta	79	WES
Down-scaling WRF winds: sensitivity & validity	Mark Kelly, Rogier Floors, Andrea		WES
	Hahmann	80	
Dynamic analysis of Kite-Ship interactions	Michael K. McWilliam	81	WES
Energy Management of Data Centers and Battery Systems	Zoltan Pinter, Zeenat Hameed,		WES
	Chresten Træholt	82	
EV Penetration and System Flexibility in Multiple Market Designs	Zeenat Hameed, Chresten Træholt,		WES
	Zoltan Pinter	83	
Exploring wind farm loads trends under control using surrogate models	Vasilis Pettas	84	WES
Fine-Tuning the TOPFARM SGD Driver	Julian Antony Quick	85	WES
Flexibility Value of Energy Storage Across Global Markets	Zeenat Hameed, Chresten Træholt,		WES
	Zoltan Pinter	86	
Heat pumps and home appliances as part of Energy Management	Zoltan Pinter, Zeenat Hameed,		WES
	Chresten Træholt	87	
High Fidelity Modelling of Airborne Wind Energy	Michael K. McWilliam	88	WES
How 'normal' is the wind at different scales?	Mark Kelly	89	WES
How supply chain costs from turbine upsizing could impact LCOE	Matt Shields	90	WES
Impact of electrolyzer degradation on the operation and design of a hybrid power plant with Power-to-X	Megha Gupta		WES
		91	
Layout Optimization of Wind Farms	Mikkel Friis-Møller, Pierre-Elouan		WES
	Rétoré	92	

Leveraging the Flexibility of Wastewater Treatment Plants for Energy Arbitrage and Flexibility Services	Zoltan Pinter, Zeenat Hameed, Chresten Træholt	93	WES
Life Cycle Sustainability Module for Offshore Wind Impact Assessment	Paul Kerr, Moritz Johann Gräfe, Anastasia Ioannou	94	WES
Locational Pricing and Flexibility Valuation in High-RES Markets	Zeenat Hameed, Chresten Træholt, Zoltan Pinter	95	WES
Microscale wind data to improve modelling of wind in large-scale energy system studies	Matti Koivisto	96	WES
Modelling steady state motion of floating offshore wind turbine with TLP foundation	Ju Feng	97	WES
Modelling wind-price boundary conditions for wind farm project evaluation	Vasilis Pettas, Moritz Gräfe	98	WES
Modulation of small-scale turbulence by large-scale atmospheric structures	Leonardo Alcayaga, Mark Kelly	99	WES
Optimization of maintenance routing and scheduling for offshore wind farms	Ju Feng	100	WES
Robust optimisation of offshore wind farm layouts under uncertain conditions (with RWE)	Pierre-Elouan Réthoré	101	WES
Satellite remote sensing on ocean winds	Charlotte Hasager, Krystallia Dimitriadou	102	WES
Sensitivity of power & loads with respect to flow model fidelity	Julia Steiner	103	WES
Simulation of the wake of a turbine in WRF-LES: a comparison with 3D lidar measurements	Alfredo Peña, Nikolas Angelou	104	WES
Sizing of hybrid power plants using surrogate-based high fidelity EMS under uncertainties	Rujie Zhu, Kaushik Das	105	WES
Sizing optimization of multi-technology hybrid power plants	Megha Gupta	106	WES
Stability, windspeed, and other $P(L^{-1}   \dots)$	Mark Kelly	107	WES
Stationary battery systems for energy arbitrage and flexibility services	Zoltan Pinter, Zeenat Hameed, Chresten Træholt	108	WES
Supply chain risk assessment for future wind energy systems	Matt Shields	109	WES
System Engineering for Airborne Wind Energy	Michael K. McWilliam	110	WES
Techno-economic analysis of hybrid power plants with PPA and ancillary service markets participation	Rujie Zhu, Kaushik Das	111	WES
Terrain spectra & microscale modelling	Mark Kelly	112	WES
Wake deficit models for non-uniform inflow	Julia Steiner	113	WES
Wake deficit surrogate model for fast time domain simulations	Julia Steiner	114	WES
Wake steering wind farm control considering limits of turbine yaw systems	Ju Feng	115	WES
Wake surrogate model for offshore wind farm layout optimization (with RWE)	Pierre-Elouan Réthoré	116	WES
WASP flow model sensitivity, towards uncertainty	Mark Kelly, E. Brizuelo, B. Olsen, R. Floors	117	WES
What is the interaction between the sea surface and the offshore wind conditions?	Alfredo Peña, Nikolas Angelou	118	WES
Wind Assisted Ship Propulsion	Michael K. McWilliam	119	WES

Wind energy manufacturing workforce readiness in the EU	Matt Shields	120	WES
Wind Turbine Optimization	Michael K. McWilliam	121	WES
<a href="#">Division Wind Material and Components (WMC)</a>		<a href="#">122</a>	
Advancing mechanical testing of natural fibres	Bo Madsen, Rajnish Kumar	123	WMC
Cohesive Zone Modelling of transition from stable to unstable crack propagation:	Rubén I. Erives	124	WMC
Controlling interfaces by thermal residual stresses	Kristine M. Jespersen	125	WMC
Crack growth simulation for wind turbine bearings	Matthias Stammmler	126	WMC
Damage tolerant structural design by shape optimization of wind turbine blade structures	Bent F. Sørensen	127	WMC
Design Exploration of a coning pitch bearing	Matthias Stammmler	128	WMC
Design of light-weight loading arms for fracture mechanics test	Kristine M. Jespersen	129	WMC
Experimental: Comparative Analysis of Blade Material Durability Using Whirling Arm Rain Erosion Facility	Nicolai Frost-Jensen Johansen	130	WMC
Experimental: Implementation of digital image correlation (DIC) to extract fracture resistance of composite materials	Bent F. Sørensen	131	WMC
Experimental: In-situ measurements of fracture resistance using digital image correlation from SEM	Bent F. Sørensen	132	WMC
Fatigue crack growth thresholds in elastomers	Jakob I. Bech	133	WMC
Fatigue resistance of corroded 42CrMo4 steel	Matthias Stammmler	134	WMC
Investigating dynamic effects of steel beams used in a DCB-UBM test setup	Ashish K. Bangaru	135	WMC
Micro Mechanical Properties and Failure Modes of Carbon Fiber Pultrusions: Influence of Fiber Geometry	Lars P. Mikkelsen, C.F. Niordson	136	WMC
Numerical modelling of carbon fiber wind turbine blade structures	Mathijs Peeters	137	WMC
On demand bonding and debonding of interfaces by friction	Kristine M. Jespersen	138	WMC
On-demand debonding of interfaces by alternating strong and weak bonds	Kristine M. Jespersen	139	WMC
Physics-informed machine learning for parameter identification of interface fracture of composite materials	Rubén I. Erives	140	WMC
Probabilistic modeling of operation and maintenance processes	Moritz Gräfe	141	WMC
Pycnometer method for fibre density	Bo Madsen, Agustin Canalis	142	WMC
Techno-Economic Modeling of Life-time extension	Moritz Gräfe	143	WMC
Understanding crack-tip behavior in composites at the microscale	Ashish K. Bangaru	144	WMC
Wind farm project valuation under different operational strategies and market conditions	Moritz Gräfe	145	WMC
Wind turbine blade erosion modelling	Jakob I. Bech	146	WMC
Wind Turbine Blade Thermal Image Super-Resolution and Denoising Using Diffusion Models	Xiaodong Jia, Xiao Chen, Hans-Henrik von Benzon	147	WMC

## Division Wind Turbine Design (WTD)

	Supervisor	148	
Aerodynamic Design of Ground-effect Vehicle for Sustainable Transportation	Ang Li, Mac Gaunaa	149	WTD
Analysis of Turbulent Inflow using Lidar Measurements for Aerodynamic Noise Application	F. Bertagnolio, A. Fischer	150	WTD
Analysis of Wind Turbine Noise in Non-Nominal Conditions	F. Bertagnolio, A. Fischer	151	WTD
Atmospheric Flow Characterization using Stochastic Reduced Order Model	Søren Andersen	152	WTD
Beyond superposition: advancing near-wake vortex-cylinder (NW-VC) model for curved blades	Ang Li	153	WTD
Blade Load Estimation using Sensors on Tower	Alan Wai Hou Lio, Sangwon Lee, Taeseong Kim	154	WTD
CFD and ROM of Flow over a Golf Court	Søren Andersen, Niels Troldborg	155	WTD
CFD reproduction of floating wind turbine response to nonlinear waves	Sithik Aliyar, Henrik Bredmose	156	WTD
CFD study of the impact of high tip speeds on wind turbine wakes	Emily Hodgson	157	WTD
CFD study of wake steering under wind direction uncertainty	Emily Hodgson	158	WTD
CFD-Based Multibody Simulation of Floating Vessels with Experimental Benchmarking for Offshore Operations	Sithik Aliyar, Henrik Bredmose	159	WTD
Comparing LES and engineering models for wind farm flows	Emily Hodgson	160	WTD
Consistency in Mean Velocity Estimates between Different CFD fidelities	Søren Andersen, Paul van der Laan	161	WTD
Coupling HAWC2 and OpenFOAM for High-Fidelity Simulation of Floating Offshore Wind Turbines	Sithik Aliyar, Henrik Bredmose	162	WTD
Design and analysis of a hydrofoil setup for a small leisure motor-boat or a solar challenge race boat	Mac Gaunaa, Robert Mikkelsen	163	WTD
Design and wind tunnel test of porous disc for emulated rotor thrust	Robert Mikkelsen, Jens H. Walter, Fabio Pierella	164	WTD
Design and Wind tunnel testing of a Magnus Rotor	Robert Mikkelsen, Mac Gaunaa	165	WTD
Design of an Individual Pitch Controller for a model 22MW floating wind turbine	Fabio Pierella	166	WTD
Development and verification of control strategies for wind turbine loads reduction	Fanzhong Meng, Andrew Russell	167	WTD
Dynamic Stall Wind Tunnel Measurements	Robert Mikkelsen, Mac Gaunaa, Andreas Fischer	168	WTD
Efficient aerodynamic modeling of curved blades for rotor design and aeroelastic simulation	Ang Li	169	WTD
Experimental measuring and identification of slamming loads in a Floating Wind Platform.	Ignacio Johannesen, Henrik Bredmose	170	WTD
HAWC2-MIRAS re-simulation of floating wind turbine tests	Henrik Bredmose, Ang Li, Ignacio Johannesen	171	WTD
Influence of flexibility on loads and wake of a 22MW turbine in CFD	Emily Hodgson	172	WTD
Investigation of aerofoil noise directivity in the Red Wind Tunnel	Robert Mikkelsen, Andreas Fischer, Oliver Lylloff	173	WTD
Investigation of the roll-yaw couple motion by using individual pitch control on FOWT	Fanzhong Meng, Alan Wai Hou Lio	174	WTD

Numerical investigations of the effect of flexibility on the loads of a floating wind turbine	Fabio Pierella	175	WTD
Oscillating inflow in airfoil testing using CFD and wind tunnels	Robert Mikkelsen, Mac Gaunaa, Andreas Fischer	176	WTD
Sensitivities and uncertainties in CFD of wind farm flows	Emily Hodgson	177	WTD
Study of vortex Induced vibrations on wind turbine towers	Christian Grinderslev	178	WTD
Unsteady Actuator Line	Alex M. Forsting, Georg Pirrung, Mac Gaunaa	179	WTD
Vortex induced vibrations of wind turbine blades	Christian Grinderslev	180	WTD
Yawed Rotor Wake Modeling	Mac Gaunaa, Paul van der Laan	181	WTD
<b>Industrial partnes</b>		<b>182</b>	
Battery Energy Storage regulation & stability in weak grid	Jesper Horn Pedersen	183	Artelia Energy
Wave-Induced Loads on Airtight Platforms in Offshore Wind Monopiles	Aref Moalemi	184	Rambøll
Investigating Chinese Offshore Wind Installation and O&M	Lars-André Bugge Tobaben	185	Sea Impact
Analysis and optimization of offshore renewable energy projects	Kathrine Dykes	186	Sperra
Design and Analysis of 3D concrete printed offshore structures	Kathrine Dykes	187	Sperra
Techno-economic and impact analysis for offshore renewables	Kathrine Dykes	188	Sperra
IEA reference turbine controller tuning in transient load events	Joshua Forrest	189	Wood Thilsted
Modal analysis – Quick tool for integrated load assessment	Martin Bjerre Nielsen	190	Wood Thilsted
Novel foundation type modelling in Orcaflex	Joshua Forrest	191	Wood Thilsted
Using soil hysteresis model resonant sea state	Martin Bjerre Nielsen	192	Wood Thilsted

# **Power and Energy Systems (PES)**

At the heart of Denmark's green transition, the Division for Power and Energy Systems (PES) leads the way in designing tomorrow's resilient, intelligent, and renewable-based energy systems. With over 130 researchers, engineers, and PhD-students, PES tackles the grand challenges of electrification, system integration, and digital transformation.

We work across the full spectrum of energy system innovation - from high-voltage engineering and grid stability to cyber-physical resilience and sector coupling. Our research powers the development of energy markets, power grids, Power-to-X and storage, intelligent energy solutions, sector coupling, prosumers, and e-mobility solutions, all supported by cutting-edge digital tools and AI-driven analytics.

Students joining projects in PES become part of a vibrant, collaborative environment with access to world-class facilities like PowerLab, real-world data from Bornholm's power grid, and strong partnerships with industry leaders like Energinet, Siemens Energy, Ørsted, Radius, SPIIRI, Danfoss, or other of our 200+ partners.

Whether you're passionate about modelling, control, data, or hardware, PES offers a unique opportunity to contribute to the transformation of energy systems - locally and globally. Join us in shaping the future of energy.

# ABS study and development based on electro-valves and pump

BOTH

**Project Description:** The project focuses on developing a semi-industrial Electronic Stability Control (ESC) system integrated with a wheel angular acceleration ( $\dot{\omega}$ ) estimator to enhance traction control for high-performance hybrid vehicles. Students will design the control algorithm, implement estimation techniques, and validate performance through simulation and hardware-in-the-loop (HIL) testing.

- **Understand Vehicle Dynamics and Control Principles**
  - Analyze longitudinal and lateral dynamics of hybrid vehicles.
  - Explain the role of ESC and traction control in improving safety and performance.
- **Develop and Implement Estimation Algorithms**
  - Design a wheel angular acceleration ( $\dot{\omega}$ ) estimator using sensor data and filtering techniques (e.g., Kalman filter).
  - Evaluate estimator accuracy under varying road and load conditions.
- **Design and Validate Control Strategies**
  - Implement ESC and traction control algorithms tailored for hybrid powertrains.
  - Test performance using simulation tools (MATLAB/Simulink) and HIL setups.
- **Optional: Integrate Semi-Industrial Hardware and Communication Protocols**
  - Configure CAN bus communication for real-time data exchange.
  - Deploy the controller on a semi-industrial platform (e.g., dSPACE, NI PXI) and assess real-time performance.

## Keywords:

Electronic Stability Control  
Driver-in-the-Loop  
Real-Time Vehicle Simulator  
Vehicle physics  
Tyre mathematical model

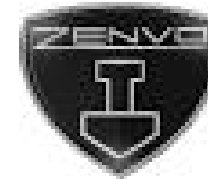

## Contact & Information

Contact person: Nenad Mijatovic  
Mail: [nemi@dtu.dk](mailto:nemi@dtu.dk)  
Division: Power and Energy Systems  
Master thesis: X  
Bachelor project:  
Can be both: X

# Aggregating thermal energy storages for energy flexibility

BOTH

## Summary

The project aims to develop a modelling framework for the coordinated control and optimal operation of aggregated Thermal Energy Storage (TES) devices - both sensible and latent heat storages - for energy flexibility. The project will demonstrate intelligent coordination of aggregated TES devices for enhanced energy flexibility.

## Keywords

Coordinated Control

Energy flexibility

Thermal Energy Storage

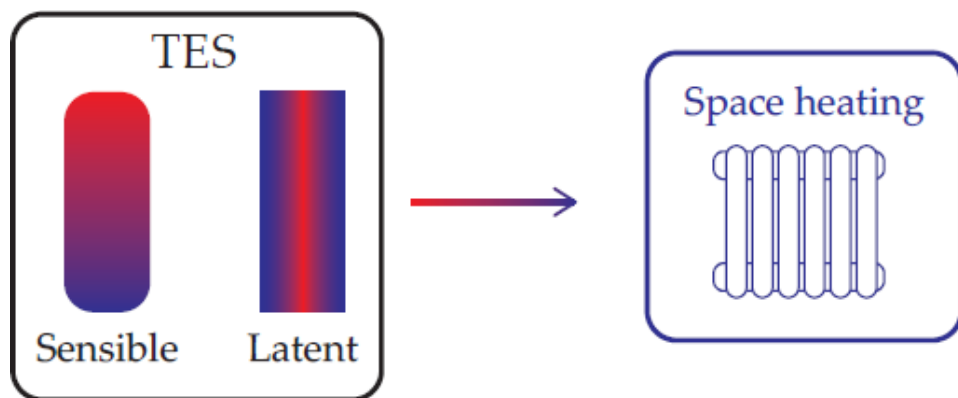

## Contact & Information

Contact person: Aneesh Nunna; Yi Zong

Mail: [anecha@dtu.dk](mailto:anecha@dtu.dk); [yizo@dtu.dk](mailto:yizo@dtu.dk)

Division: Power and Energy Systems

Master thesis: X

Bachelor project: X

Can be both: X

## Context and challenge:

**Model Predictive Control (MPC)** enables fast dynamic response in complex systems with high flexibility, handling constraints and multivariable control using its cost function. However, inaccurate system models, parameters variations, and high computational load limit real-time performance, especially in fast dynamic systems such as **power converters**. **Data-driven control** methods can tackle these challenges.

**Objective:** Design and implement an ANN data-driven controller, capable of handling parameter variations, achieving high dynamic performance with low computational burden.

## Project tasks

- Review state-of-the-art control methods for drives with sine filters.
- Simulate baseline controllers and data-driven controller under system parameter mismatch.
- Validate experimentally and compare results.
- Write the master thesis.

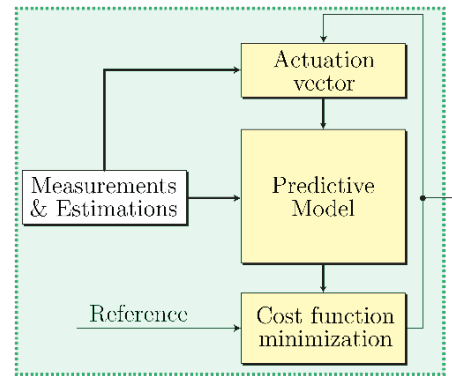

Control Algorithm

Advanced control method (MPC)

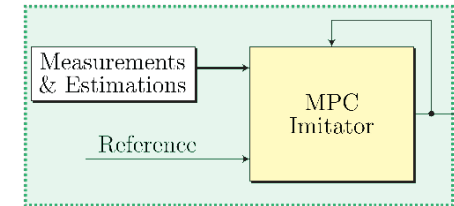

Control Algorithm

MPC imitator (ANN-driven control)

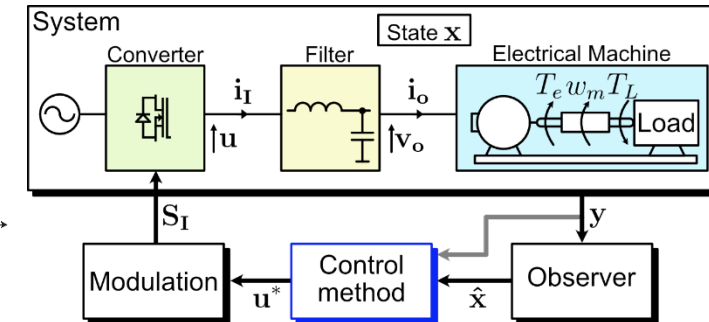

## Keywords

Model predictive control  
Data-driven control  
Power electronics  
Electric drives  
Sinusoidal filters

## Contact & Information

Contact person: Miguel Lopez  
Email: [melga@dtu.dk](mailto:melga@dtu.dk)  
Division: Power and Energy Systems  
Master thesis: X



Smart converter lab at DTU Lyngby campus

# Behavioral Insights into EV User Providing in Flexibility Services

This thesis explores how EV users respond to participating in flexibility services that prolong the duration of overnight charging sessions. Using data from the e2flex research project (<https://wind.dtu.dk/e2flex>), the student will investigate changes in user behavior, satisfaction, and willingness to provide flexibility over time. The study will combine quantitative analysis of charging patterns with qualitative insights from user feedback to assess the impact of flexibility provision on user behavior and participation acceptance.

## Key Tasks:

- Analyze changes in user charging behavior due to flexibility provision.
- Track user participation trends over time.
- Correlate behavioral changes with service activation events.
- Evaluate user feedback and satisfaction metrics.

The project will contribute to the research project e2flex: <https://wind.dtu.dk/e2flex>

## Keywords

EV User Behavior  
Flexibility Services  
Charging Patterns  
User Acceptance  
Behavioral Analysis



## Contact & Information

Contact person: Tilman Weckesser  
Haris Ziras  
Mail: [tweck@dtu.dk](mailto:tweck@dtu.dk), [chazi@dtu.dk](mailto:chazi@dtu.dk)  
Division: Power and Energy Systems  
Master thesis: X  
Bachelor project: X  
Can be both: X

# BESS as flexibility platform

Short description of the thesis/project idea

## Background

Introducing distributed renewable resources (RES) wind, PV, EVs and battery energy storage systems (BESS) leads to the rapidly changing load landscape. A particular challenge is the bi-directional power flow and the increase in max-min loading in the distribution network. Congestions show up in transformer and line overload and/or voltage violations. Most congestion and voltage excursions can be mitigated by BESS functioning as buffer, or proxy for a temporary line expansion. .

## Task

The main objective of this MSc/BSc thesis project is to explore (experimentally/model & simulation) how a BESS co-located with a substation may constitute a physical manifestation of a flexibility platform for congestion management, voltage management and virtual asset expansion.

## Industrial opportunity

DSO's such TREFOR, SEV or solution providers such as Danfoss or Hitachi.

## Keywords

- Battery systems
- Substations
- Congestion management
- Voltage management
- Grid simulation

## Contact & Information

Contact person: Shi You

Mail: [shyo@dtu.dk](mailto:shyo@dtu.dk) or [ctra@dtu.dk](mailto:ctra@dtu.dk)

Division: Power and Energy Systems

Master thesis: X

Bachelor project: X

Can be both: X

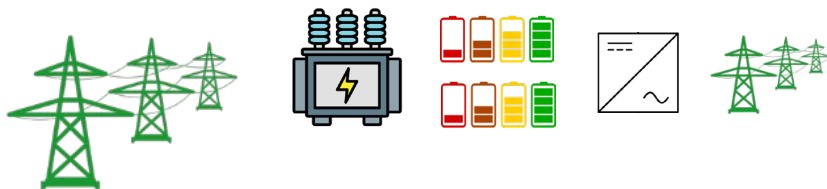

# Black start from BESS

Short description of the thesis/project idea

## Background

Introducing active front end converter-based resources (RES) wind, PV and battery energy storage systems (BESS) leads to the loss of inertia and short circuit capabilities. A particular challenge is black start where e.g. inrush currents in transformers and rotating machines may cause voltage dips, and in worse case trip protection relays. Traditionally loads are energized sequentially.

## Task

The main objective of this master thesis project is to explore (experimentally/model & simulation) an alternative solution to black start, where e.g. an electrically isolated radial is energized by controlled ramping of the voltage from low voltage to nominal voltage, e.g. 400V, while selected loads are kept connected. Topics of interest are the design and control of the voltage ramp, and how this affects transformers, different loads, and the protection gear.

## Industrial opportunity

DSO's such TREFOR, SEV or solution providers such as Danfoss or Hitachi.

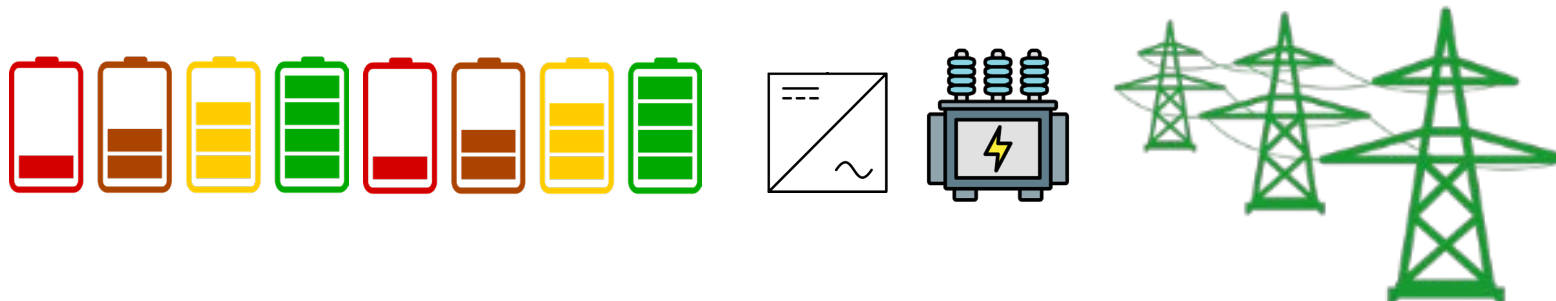

## Keywords

- Battery systems
- Substations
- Grid protection
- Fault ride through
- Black start
- Transient grid simulation

## Contact & Information

Contact person: Shi You

Mail: [shyo@dtu.dk](mailto:shyo@dtu.dk) or [ctra@dtu.dk](mailto:ctra@dtu.dk)

Division: Power and Energy Systems

Master thesis: X

Bachelor project: X

Can be both: X



<https://capital.com/electric-vehicles-on-the-brink-of-mass-adoption>

Understanding EV charging behavior is crucial for the transition to e-mobility:

- Identifying flexibility of charging sessions
- Utilizing smart charging for proactively supporting the green transition
- Optimal placement of charging infrastructure

## Project tasks:

- Review and analyze EV charging data for different locations: home charging, workplace charging, public charging, etc.
- Develop a framework for quantifying the flexibility of charging sessions, both on a vehicle and on a cluster level.

## Keywords:

- Electric vehicles
- Charging behaviour
- Statistical analysis
- Probability distributions
- Flexibility quantification

## Contact & Information

Contact person: Jan Engelhardt

Mail: [janen@dtu.dk](mailto:janen@dtu.dk)

Division: Power and Energy Systems

Master thesis: X

Bachelor project: X

Can be both: X

# Comparison of System Stability between IBRs with grid forming vs. grid following inverters

**Project Description:** This project investigates how replacing synchronous generators with inverter-based resources (IBRs) affects system stability in an IEEE bus model (Nordic or similar). Students will analyze frequency and voltage stability under two converter control paradigms: grid-following and grid-forming. The study will involve dynamic simulations under fault and disturbance scenarios to assess the ability of IBRs to maintain stability compared to traditional synchronous machines.

- Understand Stability Fundamentals and Converter Control Modes
  - explain frequency and voltage stability concepts in power systems.
  - differentiate between grid-following and grid-forming converter control strategies.
- Model and Simulate System Configurations
  - Implement an IEEE bus system with varying ratios of synchronous generators and IBRs
  - Configure dynamic models for grid-following and grid-forming converters.
- Perform Stability Analysis
  - Evaluate system response to disturbances (e.g., load changes, faults) for each configuration.
  - Compare frequency and voltage stability metrics across scenarios.
- Assess Impact of Converter Control on System Resilience
  - Identify conditions where grid-forming converters outperform grid-following in stability.
  - Provide recommendations for optimal integration of IBRs in low-inertia systems.

## Keywords:

Frequency Stability

Voltage Stability

Inverter-Based Resources (IBRs)

Grid-Following Converters

Grid-Forming Converters

Low-Inertia Power Systems

Dynamic Simulation

## Contact & Information

Contact person: Nenad Mijatovic

Mail: [nemi@dtu.dk](mailto:nemi@dtu.dk)

Division: Power and Energy Systems

Master thesis: X

Bachelor project: X

Can be both: X

# Conditional connection agreements for transformer congestion reduction: a large-scale analysis for the Copenhagen area.

## **Objective:**

The candidate will perform a large-scale analysis for a to-be-defined number of secondary substations located in the Copenhagen area. The objective is understanding how congestions can be alleviated by a widespread use of Conditional Connection Agreements between Charging Point Operators (CPOs) and Electro Mobility Service Provides (EMSPs).

## **Outcomes:**

- Control algorithm for the EV chargers to respond to a distribution system operator signal
- Grid impact analysis for the considered secondary substations, including power flow model

## **Steps:**

1. Literature review on the work already performed on the topic, with particular focus on the FLOW project results.
2. Initial “inventory” of the available datasets for transformer loading, and preliminary analysis on the number of substations to consider for the thesis.
3. Creation of simulation scenarios for the selected number of substations with increasing numbers of EV charging stations.
4. Three-phase balanced power flow analysis of the selected substation networks (if available), and analysis of the grid impact results.

## **Keywords:**

- Electric vehicles
- Transformer congestion management
- Distribution System Operator

## **Contact & Information**

Contact person: Mattia Secchi

Mail: [matsec@dtu.dk](mailto:matsec@dtu.dk)

Division: Power and Energy Systems

Master thesis: X

# Converter induced transformer diagnostics

Short description of the thesis/project idea

## Background

Introducing active front end converter-based resources (RES) wind, PV and battery energy storage systems (BESS) leads to the loss of inertia and short circuit capabilities. A particular challenge for grid-forming converters in conjunction with BESS is inrush currents in transformers and charging currents in cables. This may cause voltage dips, and in worse case tripping of protection relays. Knowledge of transformer, cable and load characteristics may enable a more safe and optimal operation of the system.

## Task

The main objective of this master thesis project is to explore (experimentally/model & simulation) if and how much component specific information can be "read" by active front end converters connected to e.g. a transformer and/or cable including conventional loads. The objective is to enable an optimal dynamic operation of BESS, transformers and cables on a substation avoiding unintentional tripping of protection gear.

## Industrial opportunity

DSO's such as TREFOR, SEV or solution providers such as Danfoss or Hitachi.

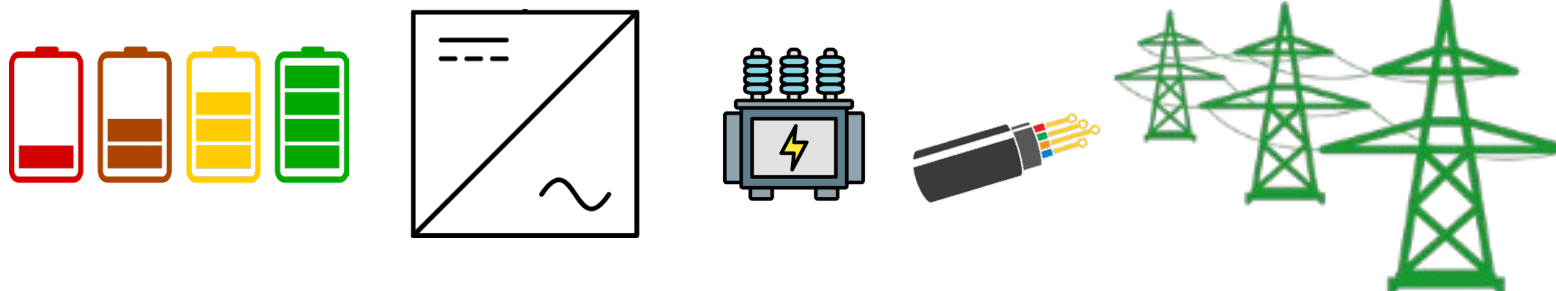

## Keywords

- Substations
- Active front end converter
- Embedded diagnostics
- Fault ride through
- Black start
- Transient grid simulation

## Contact & Information

Contact person: Nenad Mijatovic

Mail: [nemi@dtu.dk](mailto:nemi@dtu.dk) or [ctra@dtu.dk](mailto:ctra@dtu.dk)

Division: Power and Energy Systems

Master thesis: X

Bachelor project: X

Can be both: X

## Description:

This research project wants to address the environmental benefits of V2G schemes, including battery degradation and life-cycle impacts of Li-ion batteries.

## Objective:

Develop a degradation model under V2G cycling patterns and compare them with a standard EV use from different perspectives (environmental, economic, etc) The study explores the benefits of using low-impact electricity stored in car's battery pack (offset of fossil fuel-based electricity) at grid-local level.

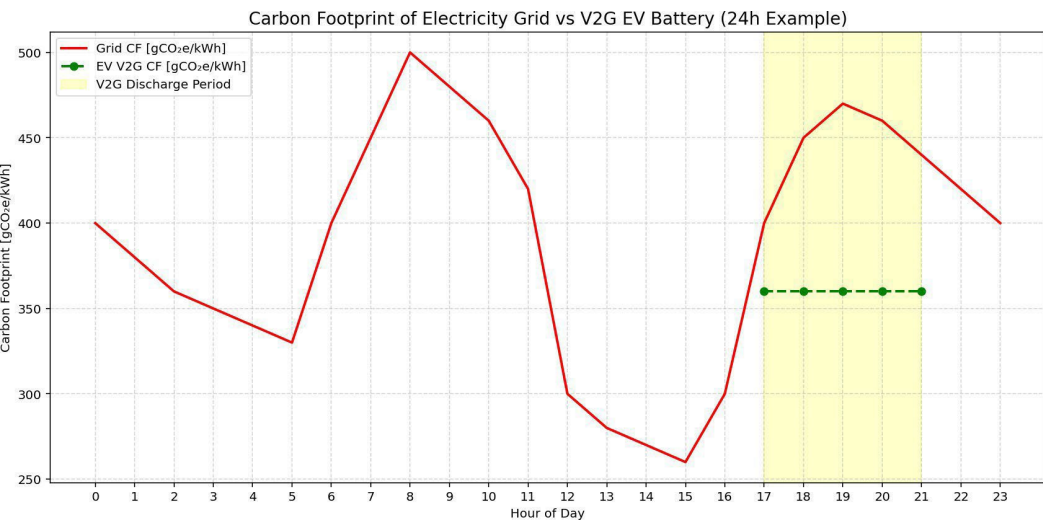

## Keywords:

- Degradation model
- V2G services
- Life Cycle Assessment

## Prerequisites

- Python

## Contact & Information

Contact person: Leonardo Ferhati

Mail: [leofe@dtu.dk](mailto:leofe@dtu.dk)

Division: Power and Energy Systems

Master thesis: X

Bachelor project: X

Can be both: X

## Summary

The project aims to develop a hybrid modelling framework that combines data-driven machine learning with physics-informed models to accurately simulate Phase Change Material (PCM) based Thermal Energy Storage (TES) devices. Such a modelling framework will be able to learn from both historical and real-time experimental data to deliver fast, accurate forecasts of the thermodynamic behaviour of the TES for application within predictive control strategies for intelligent energy management.



## Keywords

Machine learning  
Numerical modelling  
Phase Change Material  
Thermal Energy Storage

## Contact & Information

Contact person: Aneesh Nunna; Yi Zong  
Mail: [anecha@dtu.dk](mailto:anecha@dtu.dk); [yizo@dtu.dk](mailto:yizo@dtu.dk)  
Division: Power and Energy Systems  
Master thesis: X  
Bachelor project: X  
Can be both: X

# Detection of EV charging in a large residential smart meters dataset.

## **Objective:**

The candidate will develop an AI-based model to detect the presence of single or three-phase EVs charging in the residential sector. The model will be trained on a large dataset of EV charging profiles from one of the most utilised Danish E-mobility services providers, and applied to a large dataset of point of distribution (POD) smart meters connected to the LV distribution network of Copenhagen and surroundings.

## **Outcomes:**

- Pattern recognition model to detect the presence of single or three-phase EV charging on the POD smart meters.

## **Steps:**

1. Literature review of the available models for detection of patterns in timeseries.
2. Analysis of the available smart meter and EV charging datasets.
3. Creation of the EV detection tool, and validation of the results.

## **Keywords:**

- Electric vehicles
- Smart metering data
- Pattern recognition
- Data science

## **Contact & Information**

Contact person: Mattia Secchi

Mail: [matsec@dtu.dk](mailto:matsec@dtu.dk)

Division: Power and Energy Systems

Master thesis: X

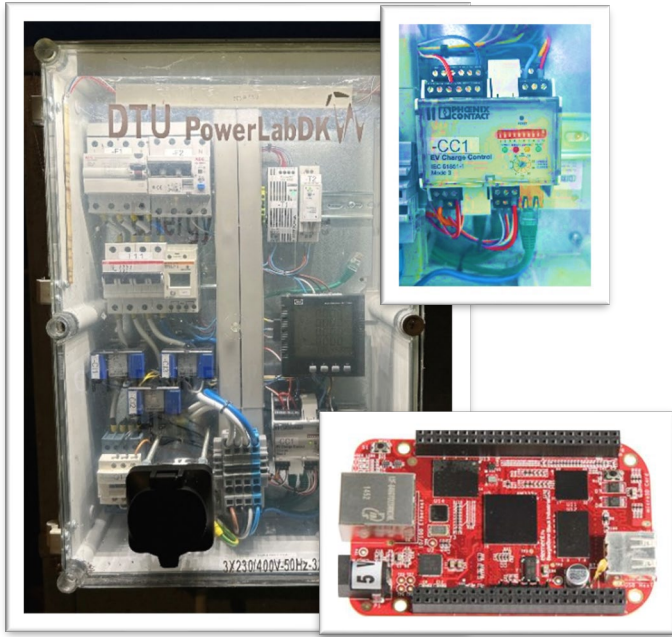

EV smart chargers are a crucial step in unleashing the potential of EVs in driving the green transition.

Key tasks of smart chargers are:

- Control the charging session to meet user needs
- Communication with external systems
- Coordination with other chargers and units

## Project tasks:

- Use the existing hardware of a charger and **make it smart**. The charger is already capable of:
  - (i) giving setpoints, (ii) measuring the power, (iii) communicating with external system
- **Program a microcontroller** to make informed decisions and communicate with other chargers in the network
- Experimental comparison of **centralized** and **distributed control strategies**

## Keywords:

- Electric vehicles (EVs)
- Smart charging
- Load management system
- Microcontroller

## Contact & Information

Contact person: Jan Engelhardt

Mail: [janen@dtu.dk](mailto:janen@dtu.dk)

Division: Power and Energy Systems

Master thesis: X

Bachelor project: X

Can be both: X

# Digitalization value assessment for smart meter data

BOTH

Distribution grids are under pressure from electrification and imbalanced grids have a lot of unused grid capacity, cause grid losses and even local outages. **What if grid operator could automatically tell an electrician via an app, which of the three grid phases currently would be the best to connect a heat pump or EV charger to?** Motivated by this idea we have built a data pipeline leading from smart meter measurements to a three-phase power flow and other valuable machine learning-based detection and identification techniques.

This empirical thesis should **evaluate how the data and these techniques generate the value for the grid operator and customers.** This work is based on prior results which have already proven interesting to the DSO, each in different areas of their business. Here the DSO would like to support a project to identify and model various value streams that arise from such data can be appraised.

The 3PhaseInsight project has access to **a unique data set** of 100k per-phase (3-phase) smart meter measurements. Access to this data set enables to explore the feasibility of novel data-driven methods, and to develop and validate their applicability in a realistic setting. First results already demonstrate how typical assumptions in the academic literature are challenged and that methods can be refined through this data set.

This thesis may be carried out in **collaboration with Radius**, Denmark's largest distribution grid operator (DSO), and responds to a specific need that DSOs will have more and more in the near future.

## Keywords

Phase imbalance, distribution grid, AI, Smart Metering Data, Residential Consumption

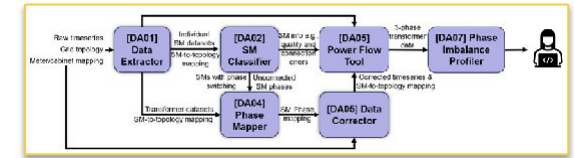
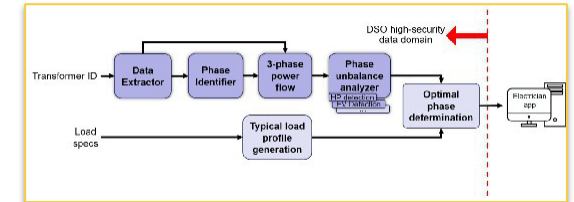

Payoff positive ?

## Contact:

Name: Kai Heussen

Mail: [kheu@dtu.dk](mailto:kheu@dtu.dk)

Division: Power and Energy Systems & Radius

Master thesis: X

Bachelor project: X

Can be both: X



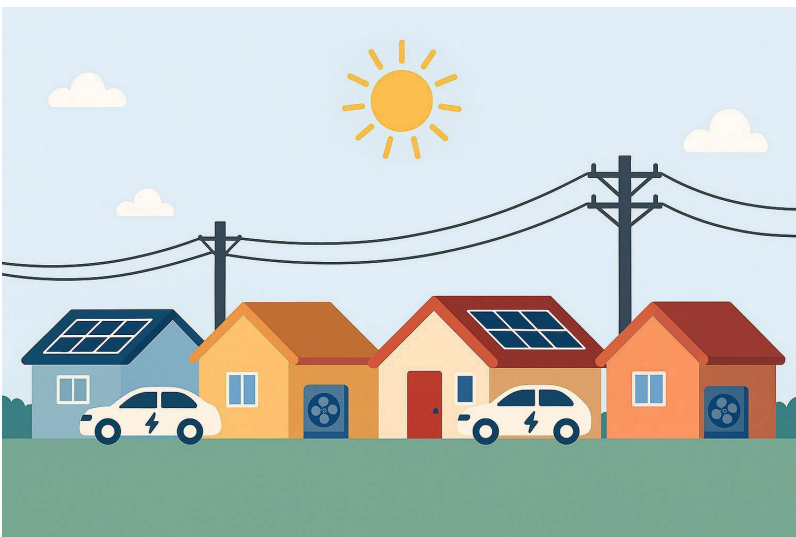

As distributed energy resources like **electric vehicles, heat pumps, and photovoltaic systems** become more common, local grid infrastructure faces challenges.

This thesis project investigates **coordination strategies among households** in close proximity, to mitigate these issues. This will ultimately enable a smooth integration of small-scale energy technologies in our power system.

Thesis goals:

- A **simulation model** of a neighborhood comprising several households and various distributed energy resources: electric vehicles, rooftop solar, heat pumps.
- Developing **coordination mechanisms** that enhance grid stability while respecting user autonomy and data protection.
- Comparing solutions with **different degrees of communication**.

## Keywords:

- Prosumers
- Electric vehicles
- Rooftop PV
- Energy Coordination
- Residential areas

## Contact & Information

Contact person: Jan Engelhardt

Mail: [janen@dtu.dk](mailto:janen@dtu.dk)

Division: Power and Energy Systems

Master thesis: X

Bachelor project: X

Can be both: X

# Energy Management for Offshore-Wind-Hydrogen Systems

## Project background

Offshore wind energy is emerging as a pivotal component of the global renewable energy portfolio. However, its inherently variable output, driven by fluctuating weather conditions, poses significant challenges for balancing electricity supply and demand within the power grid. One widely recognized strategy to address this issue involves converting excess offshore wind power into hydrogen via electrolysis. Hydrogen produced in this manner can be stored and subsequently utilized to deliver energy services, thereby enhancing system flexibility and contributing to the broader goals of energy decarbonization. Nevertheless, **integrating electrolyzers into systems** dominated by variable renewable energy sources presents a range of **technical, economic, and operational challenges** that must be carefully addressed.

## Research objectives

The project will focus on developing a system operation-oriented digital twin to support offshore wind farms and other key surrounding components, such as energy storage (**hydrogen electrolyzers and batteries**), for optimal integration into a more stable and resilient energy system. This will be achieved by developing an advanced data-driven model-based energy management system, which includes the following potential tasks:

- Multi-timeframe **modeling** of the selected electrolyzers for offshore wind
- Stability-oriented **operation and control strategies** simulation and validation for offshore wind to support ancillary services.
- Data-driven **technical-economic assessment and transaction energy management strategies** for offshore wind and its surrounding storage assets participating in energy to reduce operation costs.

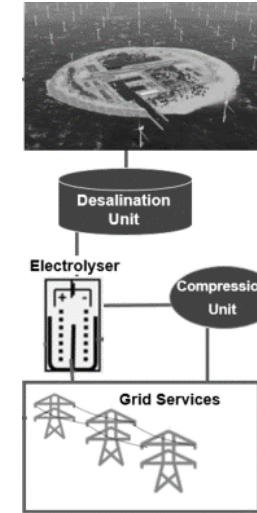

**Keywords:** Energy management system; hydrogen production and integration; modeling and optimal operation; offshore wind

## **Contact & Information**

Contact person: Aneesh Nunna, Yi Zong

Mail: [anecha@dtu.dk](mailto:anecha@dtu.dk); [yizo@dtu.dk](mailto:yizo@dtu.dk)

Division: Power and Energy Systems

Master thesis: X

Bachelor project: X

Can be both: X

# Enhancing Grid Resilience through Next-Generation Battery Storage

BOTH

This thesis will develop a high-fidelity battery energy storage system (BESS) simulation to quantify the enhancement of power system resilience and renewable integration with next-generation batteries, including technologies such as solid-state batteries, sodium-ion batteries, or other new chemistries or manufacturing formats. After integrating the BESS from the cell to the system, this research aims to implement a new battery system into the modern power system for grid connection, renewable integration, grid resilience, and other purposes. The opportunity to test the battery cells in the advanced facilities at DTU PowerlabDK will be offered. Furthermore, the modeling focus is on utilizing tools such as a Python-based simulation framework or other commercial battery simulation tools that employ physics-based or data-driven methodologies. The simulation will assess the response, lifetime, safety, efficiency, and other relevant aspects of power system applications related to maintaining optimal system performance, including stability, preventing blackouts, and minimizing renewable curtailment during contingency events. This allows to see how next-gen batteries restore stability, tangibly showcasing the impact of electric engineering technically and economically.

## Keyword

Battery energy storage system,  
 Next-Gen Batteries,  
 Data-driven research,  
 Power System Resilience,  
 Renewable Integration,  
 Hardware test,  
 Software Simulation.

## Contact & Information

Contact person: Chunyang Zhao & Chresten Traeholt  
 Mail: [chuzh@dtu.dk](mailto:chuzh@dtu.dk) [ctra@dtu.dk](mailto:ctra@dtu.dk)  
 Division: Power and Energy Systems  
 Master thesis: X  
 Bachelor project: X  
 Can be both: X

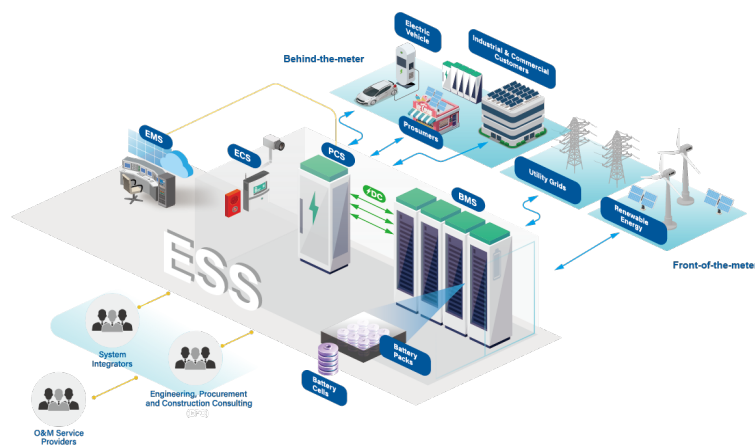

**Sodium-Ion + Solid-State Batteries: State of the art**  
 These performance parameters are targeted to be achieved by Sodium-ion and Lithium-SSB

	Na Sodium-Ion			Li Solid-State Battery		
	Layered oxide	Prussian Blue Analogs		Oxide Solid Electrolyte	Polymer Solid Electrolyte	Sulfur Solid Electrolyte
Gravimetric Capacity	50 Ah/kg	50 Ah/kg	40 Ah/kg	48 Ah/kg	97 Ah/kg	122 Ah/kg
Volumetric Capacity	75 Ah/l	90 Ah/l	85 Ah/l	65 Ah/l	278 Ah/l	106 Ah/l
Gravimetric Energy	160 Wh/kg	155 Wh/kg	125 Wh/kg	150 Wh/kg	350 Wh/kg	440 Wh/kg
Volumetric Energy	240 Wh/l	280 Wh/l	255 Wh/l	200 Wh/l	1000 Wh/l	380 Wh/l

© FutureBatteryLab.com Data from publicly accessible cell data sheets.

The 3PhaseInsight project has access to a **unique data set** of about 100k per-phase (3-phase) smart meter measurements. Access to this data set enables to explore the feasibility of **novel data-driven methods**, and to develop and validate their applicability in a realistic setting. First results already demonstrate how typical assumptions in the academic literature are challenged and that methods can be refined through this data set.

The main objective of this thesis is to **generate typical time series of consumption based on** a generative time series model and **approximate labels** derived from straightforward heuristics and existing labeling models. The work will thus combine several AI-based methods (entity-based time series models [1] and labelling models), to generate hypothetical load patterns for grid planning. Data pipeline, labelling results and times series data are already available, so this project will focus on the generative ML model development.

This thesis may be carried out in **collaboration with Cerius-Radius**, Denmark's largest distribution grid operator (DSO), and responds to a specific need that DSOs will have more and more in the near future.

[1] K. Bölät, Simon H. Tindemans, *One Model to Forecast Them All and in Entity Distributions Bind Them*, PowerTech 2025 <https://research.tudelft.nl/en/publications/one-model-to-forecast-them-all-and-in-entity-distributions-bind-t>  
Source code: <https://github.com/kabolat/behavio-temporal-vaе>

## Keywords

Statistical modeling, machine learning, entity-based models, generative AI, ML, Smart Metering Data, Residential Consumption

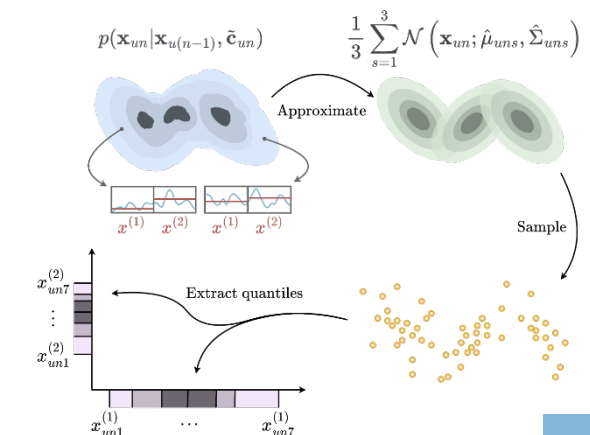

## Contact & Information

Contact person: Kai Heussen

Mail: [kheu@dtu.dk](mailto:kheu@dtu.dk)

Division: Power and Energy Systems & Radius

Master thesis: X

## Background:

- The number of **Electric Vehicles (EVs)** is rapidly increasing in Denmark, and it is expected that a **large share of the users will use home chargers** to satisfy their charging needs.
- EV chargers are a **new type of consumer in the distribution grid**, which are **connected through power electronics** to the distribution grid.
- In various previous works, it has been suggested that EVs can **provide system services**, e.g. frequency support. Therefore, they may play an important role in **power system stability studies**.

## In this project:

- You will develop a **detailed dynamic EV charger model in PowerFactory** based on models published in literature
- You will **extend the model with selected controllers** relevant for power system stability studies, e.g. frequency droop control, voltage control, fault-ride through.
- You will **integrate the EV charger model** in PowerFactory
- You will **test and validate your model** with dynamic simulations
- Finally, you will **characterize the dynamic behavior of a fleet of EVs** at the interface between DSO and TSO

## Keywords

Power system resilience  
Power system dynamics  
PowerFactory  
Electric vehicles (V2G)



## Contact & Information

Contact person: Tilman Weckesser  
Mail: [tweck@dtu.dk](mailto:tweck@dtu.dk)  
Division: Power and Energy Systems  
Master thesis: X

# Evaluating Economic Trade-offs in Flexible EV Charging Management

This thesis will investigate the dual perspective of flexible EV charging management by quantifying both user cost savings and the economic implications for service providers. Using historical charging data and scenario simulations, the thesis will provide a comprehensive framework for evaluating trade-offs between user incentives and sustainable revenue mechanisms in third-party managed charging systems.

The project will contribute to the research project e2flex: <https://wind.dtu.dk/e2flex>

## Keywords

Electric vehicle charging  
Flexibility  
Economic analysis

# Spirii



## Contact & Information

Contact person: Haris Ziras & Margarita Chatzouli

Mail: [chazi@dtu.dk](mailto:chazi@dtu.dk)

Division Power and Energy Systems &  
Spirii Master thesis: X

# Evaluating the Identification of Residential EV Chargers Across Different Data Environments

The increasing penetration of electric vehicles (EVs) presents new challenges for Distribution System Operators (DSOs), particularly in managing load and planning infrastructure in the low-voltage grid. This thesis aims to develop a machine learning methodology to identify residential EV charging events occurring "behind the meter", with a particular focus on the availability and granularity of data (local DSO-level vs. national-level) affects model selection, development, and performance.



## Keywords

EV charging  
DSO

Grid planning  
Smart meter data



## Contact & Information

Contact person: Bjarke Bak

Mail: [bbak@dtu.dk](mailto:bbak@dtu.dk)

Division: Power and Energy Systems  
& Konstant Net & Green Power DK

Master thesis: X

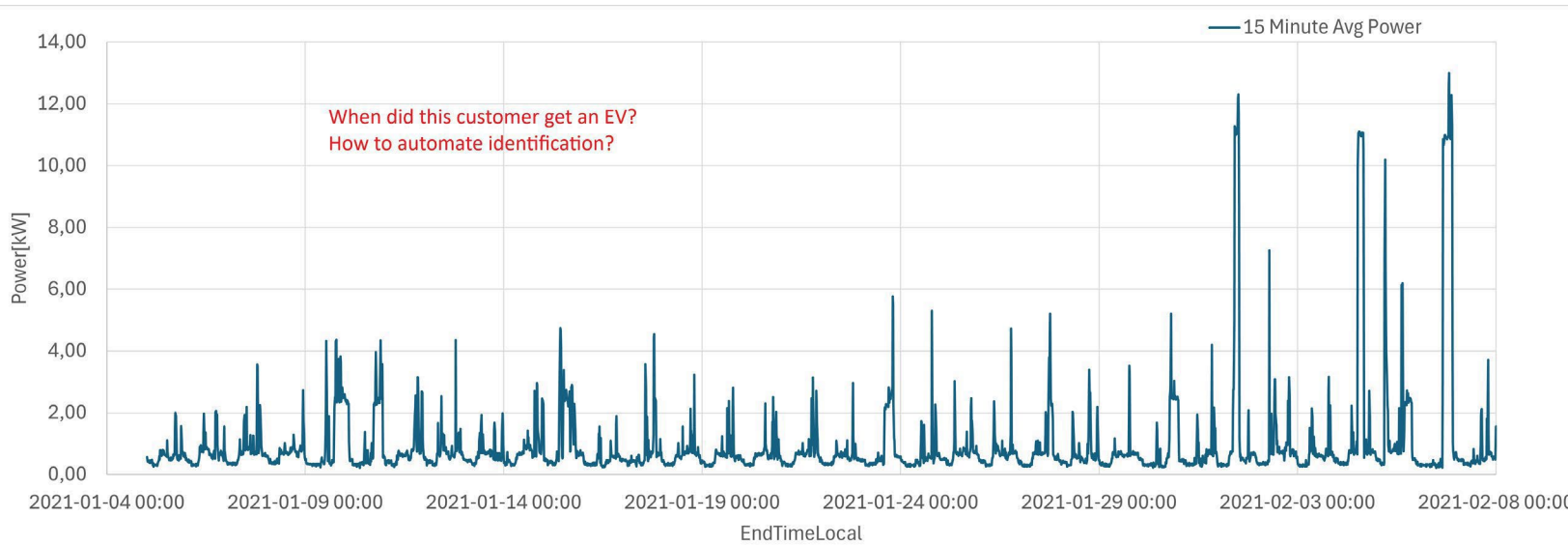

# Eventure BlueDot / Vermilion Racing Project

## Design requirements for integrating hub motors in Vermilion: Hub Motors development racer



### Keywords:

Electric Vehicles, Motor Sport, drivetrain, motor drive design, battery pack and BMS, composite structures, system simulation



- Design / create torque vectoring model and developed a design for the wheel hub motors (in close collaboration with mechanical design responsible)
- Evaluate the integration and performance of the HUB motor design based on 3D Finite Element Electro Magnetic Transient model
- Perform the optimization for the power density and efficiency
- Extract the motor parameters from FE model and develop the Simulink model
- Evaluate manufacturing capability, mapping the poll of suppliers

### Contact & Information

Contact person: Nenad Mijatovic

Mail: [nemi@dtu.dk](mailto:nemi@dtu.dk)

Division: Power and Energy Systems

Master thesis: X

Bachelor project: X

Can be both: X

# Eventure BlueDot / Vermilion Racing Project

## Lap time simulation modelling

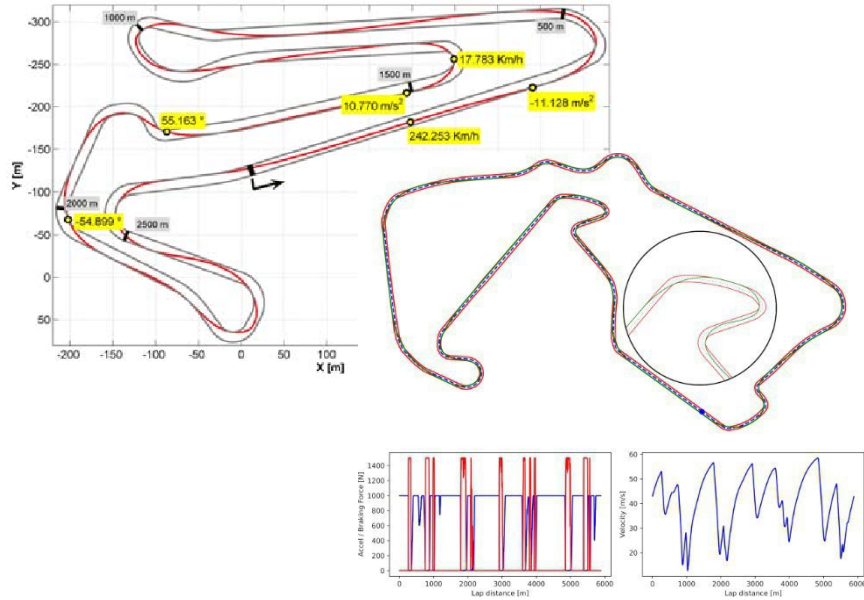

### Keywords:

High Power, Short Circuit testing standards and procedures requirements, Data acquisition and postprocessing, design and optimization

### Contact & Information

Contact person: Nenad Mijatovic

Mail: [nemi@dtu.dk](mailto:nemi@dtu.dk)

Division: Power and Energy Systems

Master thesis: X

Bachelor project: X

Can be both: X

- Investigate any existing lap time simulation model and develop requirements for the specific system you want to integrate (could be an advanced powertrains model)
- Development of Simulink system to model of lap around specific circuit
- Optimize different subsystems of the simulation and create more accurate models
- Integrate the telemetry-based validation of the developed simulation

# Eventure BlueDot / Vermilion Racing Project

## Servo Drive Steering System for Precision Vehicle Control

BOTH



### Keywords:

Electric Vehicles, Motor Sport, drivetrain, motor drive design, battery pack and BMS, composite structures, system simulation

- This project focuses on designing and implementing a servo-driven steering system for vehicles. Students will explore servo motor selection, control algorithms, and integration with steering mechanisms to achieve precise and responsive steering. The project includes modeling, hardware development, and performance validation under different load and speed conditions.
  - State of the art and FS rules review
  - Servomotor and control development with response time  $< 1\text{ms}$  and adjustable stiffness
  - Preliminary performance validation
  - Prototype development and integration in the vehicle

### Contact & Information

Contact person: Nenad Mijatovic

Mail: [nemi@dtu.dk](mailto:nemi@dtu.dk)

Division: Power and Energy Systems

Master thesis: X

Bachelor project: X

Can be both: X

# Eventure BlueDot / Vermilion Racing Project: Battery Management System (BMS) development

BOTH

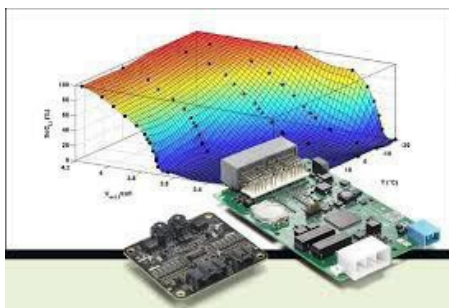

## Keywords:

High Power, Short Circuit testing standards and procedures requirements, Data acquisition and postprocessing, design and optimization



- Study of the commercially available BMS systems and performing the cost benefit analysis of existing solutions from perspective of Vermilion
- Performing the gap analysis, investigate functional and operational safety requirements of Formula students needs
- Develop the architecture of the BMS platform and perform the indetail design (Chip selection, PCB design (in Altium),
- Perform the validation and testing of the developed HW
- Devise the methodology for validation of functional testing

## Contact & Information

Contact person: Nenad Mijatovic

Mail: [nemi@dtu.dk](mailto:nemi@dtu.dk)

Division: Power and Energy Systems

Master thesis: X

Bachelor project: X

Can be both: X

# Eventure BlueDot / Vermilion Racing Project: Super-Cap storage system investigation



- Project Description: This project focuses on analyzing the characteristics, performance, and integration of supercapacitor (Super-Cap) storage systems in modern racecar drivetrain applications. Students will study energy and power density trade-offs, charging/discharging dynamics, and potential use cases such as intermediate storage for regenerative braking of EV racecar. The project will include modeling, simulation, and experimental validation using available hardware or test benches.
- Understand Supercapacitor Fundamentals and Applications
- Investigate the management of SuperCaps and model and simulate Supercapacitor pack performance
- Evaluate Integration Strategies: lightweight & efficient DC/DC converter
- (Optional) Experimental Validation

## Keywords:

High Power, Short Circuit testing standards and procedures requirements, Data acquisition and postprocessing, design and optimization



## Contact & Information

Contact person: Nenad Mijatovic

Mail: [nemi@dtu.dk](mailto:nemi@dtu.dk)

Division: Power and Energy Systems

Master thesis: X

Bachelor project: X

Can be both: X

# EVenture BlueDot / Vermilion Racing Project: Vermilion racer accumulator design

BOTH



- Multidisciplinary design requirements: electrical, structural and thermal,
- Characterization of best battery cells candidates (Examine both pouch and cylindrical cells in depth)
- Measurement interfacing PCB design and integration with BMS
- Structural design of battery segment including different battery types
- Composite Tractive system accumulator container (e.g. battery container)
- Cooling approach for accumulator design

## Keywords:

High Power, Short Circuit testing standards and procedures requirements, Data acquisition and postprocessing, design and optimization



## Contact & Information

Contact person: Nenad Mijatovic

Mail: [nemi@dtu.dk](mailto:nemi@dtu.dk)

Division: Power and Energy Systems

Master thesis: X

Bachelor project: X

Can be both: X

## Context:

This research project will continue an investigating on the impact that electric vehicles (EV) could have as price makers in electricity prices in the future. Building on an existing optimization of price maker impact in the day ahead market, the student could explore the decision making required when planning EV charging while considering multimarket bidding across the day ahead and ancillary service markets for an EV aggregator.

## Objective:

- Establish realistic bidding strategies for EV and competing ancillary service technologies.
- Use price maker methodology to include price maker impact on multimarket bidding algorithms for EV schedules.

## Outcome:

- An understanding of expected EV influence on market outcomes
- Aggregator/market operator optimisation model

## Keywords:

- EV
- Electricity Prices
- Price taker/Price maker

## Prerequisites

- Python/Julia/Matlab Expertise
- Optimisation
- Game theory

## Contact & Information

Contact person: Mathias Botoft Hansen

Mail: [botoft@dtu.dk](mailto:botoft@dtu.dk)

Division: Power and Energy Systems

Master thesis: X

Bachelor project: X

Can be both: X

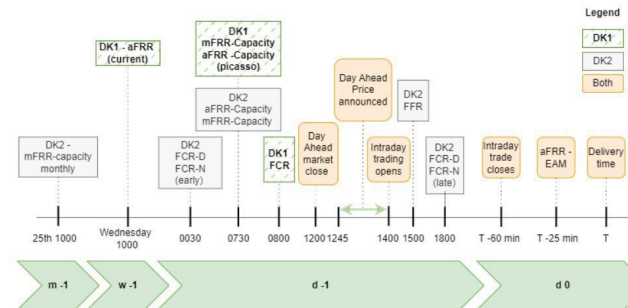
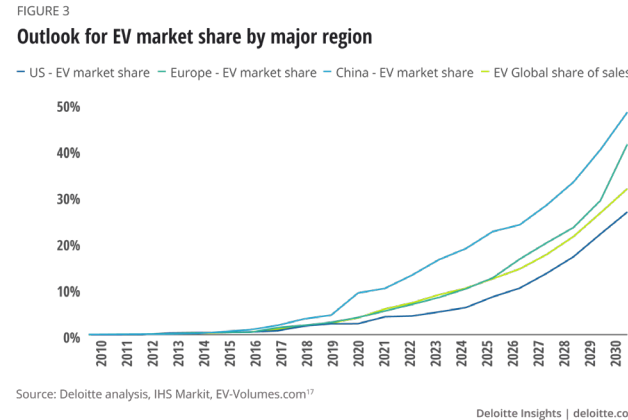

# Extreme Usage and Operational Conditions of Lithium-Ion Batteries Across Multi-Sector Applications

**Research Focus:** This thesis investigates the extreme operational cases and boundaries of lithium-ion batteries under demanding usage conditions across three critical domains:

- Electric Vehicles: Fast-charging (high C-rate) stress and intermittent discharge-charging during driving cases
- Grid Storage: Frequency regulation requiring continuous shallow cycling
- Urban Air Mobility (drone/flight): Rapid cycling for electric vertical take-off, cruising, and landing aircraft

**Methodology:** The research will employ simulation tools to model battery behavior under various real and extreme conditions, targeting the estimation and quantification of thermal runaway, degradation, and performance limits in varying environmental conditions.

**Expected Outcomes:** The project will develop operational safety envelopes and degradation models for extreme battery usage scenarios. An interactive demonstration platform will visualize real-time battery stress under different operational modes, serving as an engaging tool for energy management systems and battery management systems.

## Keywords:

Extreme Battery Usage, Operational Limits, Thermal Runaway, Multi-Sector Applications, Degradation Modeling, Safety Envelopes, BMS.

## Contact & Information

Contact person: Chunyang Zhao & Chresten Traeholt

Mail: [chuzh@dtu.dk](mailto:chuzh@dtu.dk) [ctra@dtu.dk](mailto:ctra@dtu.dk)

Division: Power and Energy Systems

Master thesis: X

Bachelor project: X

Can be both: X

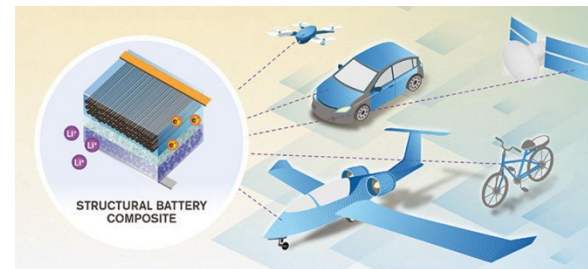
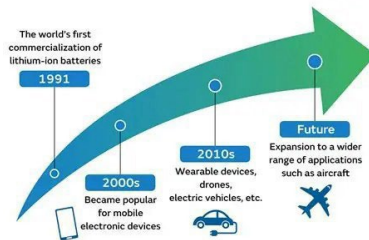

Short description of the proposal:

Joining a High Temperature Superconductive Cable takes a lot of time, involves many steps and especially the insulation can be a challenge for installers. Could you suggest and evaluate an alternative?

- Explain the basics of cables joints and joints of HTS cables.
  - Sample provided by NKT.
- Measurement on HTS tapes joints.
- Derive an electric and/or Thermal model and compare the model with measurements.
- Evaluate the current Superconductive Joint process and method and give recommendation to improve.

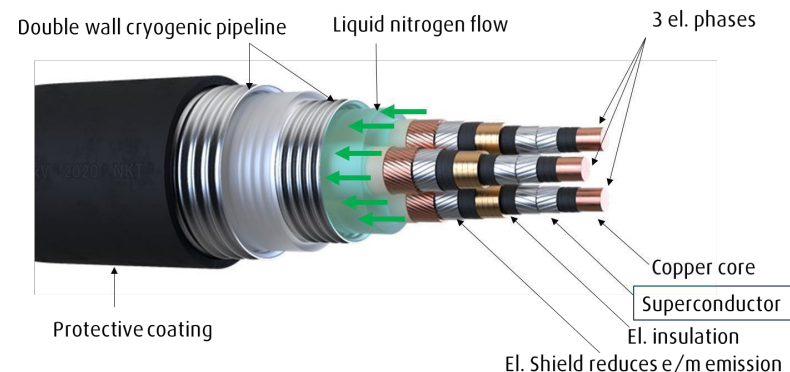

## Keywords:

Cables Joint, HTS cable Joint, Cryogenic, thermal and electrical model, R&D, HTS, High Voltage Superconductive Cable, Work with industry, Cryogenic temperatures, Real World Applications



## Contact & Information

Contact person: Nenad Mijatovic

Mail: [nemi@dtu.dk](mailto:nemi@dtu.dk)

Division: Power and Energy Systems

Master thesis: X

Bachelor project: X

Can be both: X

# Flexibility Assessment of Electrification in Cement Production

## Project background

Cement production accounts for approximately 7% of global energy-related CO<sub>2</sub> emissions. Approximately two-thirds of these emissions originate from limestone calcination, while the remainder stems from the combustion of fossil fuels for high-temperature heat. Decarbonization strategies include using Supplementary Cementitious Materials (SCMs) such as calcined clays, and electrifying heat supply with power-to-heat technologies.

**Electrifying the clay calcination process** is a crucial step toward evaluating the feasibility of power-to-heat in the cement industry. Traditionally, limestone and clay calcination run 24/7 at constant load and fuel supply. Coupling electrification with flash calcination could enable **flexible operation** through the provision of ancillary services (e.g., FCR) or energy-price arbitrage, if advantageous. Assessing this flexibility is multidisciplinary, involving process constraints (e.g., temperature limits, thermal inertia, calcination degree), power systems, and economic considerations.

## Research objectives

This project assesses the potential flexibility of an electrified clay-calcination process, building on the **FLSmidth ECoClay concept** and previous studies by DTU Kemi, DTU Compute, and DTU Wind and Energy Systems.

**Keywords:** Demand-side flexibility, power-to-heat, ancillary services, clay calcination

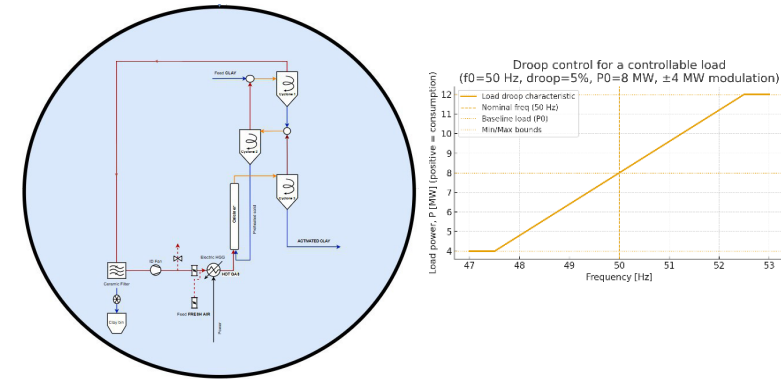

## Contact & Information

Contact person: Bruno Laurini, Yi Zong  
Mail: [brulau@dtu.dk](mailto:brulau@dtu.dk); [yizo@dtu.dk](mailto:yizo@dtu.dk)

Division: Power and Energy Systems  
Master thesis: X

# Flexibility quantification of energy assets with Bayesian models

**Context and challenge:** Transitioning to renewables makes it increasingly challenging to match electricity production and consumption in real-time. **Demand-side flexibility** can fulfill this purpose, providing balancing at a much lower cost than large-scale energy storage.

**Objective:** Develop **probabilistic modeling techniques** to quantify the flexibility available in common motor-driven electrical loads, applying machine learning tools to real-world data.

## Project tasks

- Understand stochastic and Bayesian modeling methods.
- Analyze real-world data from wastewater facilities.
- Develop uncertainty-aware flexibility estimation methods.
- Simulate, validate, and document your findings.

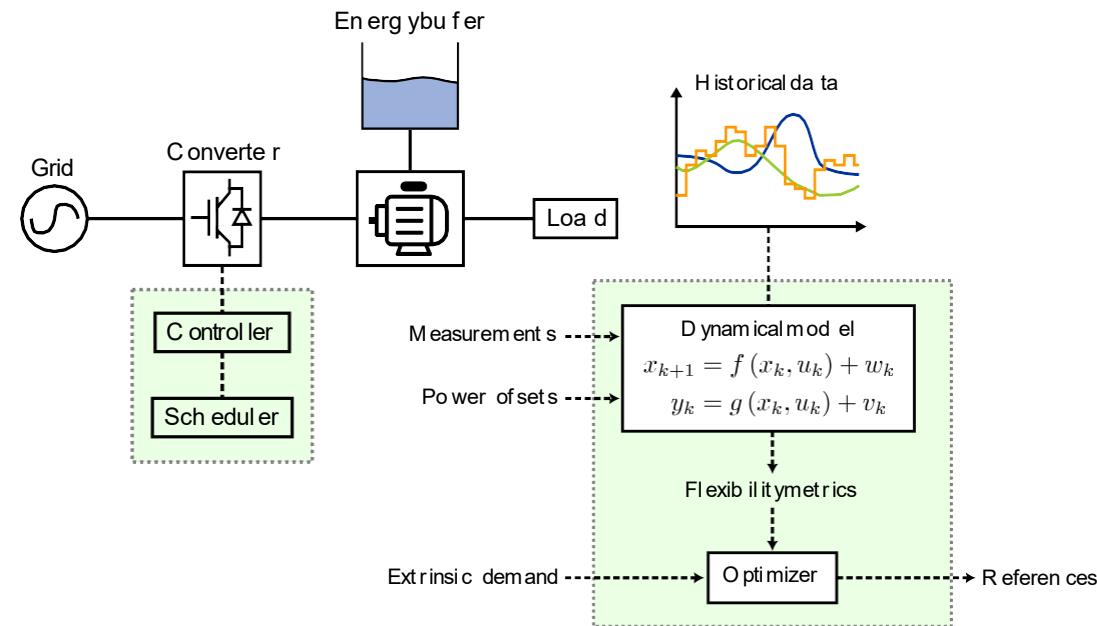

## Keywords

Flexibility  
Bayesian modeling  
Stochastic optimization  
State estimation  
Control systems  
Power conversion

## Contact & Information

Contact person: Pere Izquierdo

Mail: [pizgo@dtu.dk](mailto:pizgo@dtu.dk)

Division: Power and Energy Systems

Master thesis: X

# Frequency support via residential bidirectional EV chargers: a large-scale analysis for a Danish aggregator

## **Objective:**

The candidate will build on the existing literature regarding frequency support via electric vehicles from residential charging stations, with a specific focus on how much bidirectional charging (V2G) could be profitable for an EV aggregator. The candidate will leverage on the large EV charging dataset available in our section, and a previous thesis on the same topic, which will constitute the basis of this work.

## **Outcomes:**

- Decision model for bidding in the FCR-D and aFRR up and down markets as single markets, or in a multi-market fashion.
- Profitability analysis for an aggregator, based on real world data.

## **Steps:**

1. Literature review of the work previously performed on the topic, and on the functioning of the frequency support products and markets in Denmark.
2. Adaptation of the currently available model (V1G only) to the new dataset.
3. Analysis of the prices of the considered frequency markets, and first evaluation of the profitability with V1G.
4. Update of the model to consider V2G, and calculate the profitability for an aggregator.

## **Keywords:**

- Electric vehicles
- Frequency support
- V2G
- Aggregator bidding

## **Contact & Information**

Contact person: Mattia Secchi

Mail: [matsec@dtu.dk](mailto:matsec@dtu.dk)

Division: Power and Energy Systems

Master thesis: X

# Hybrid PtX & Batteries in power systems

## Short description of the thesis/project idea

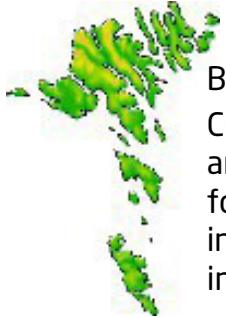

### Background

Currently e.g. Faroe Islands curtail about 30% wind production on an average annual base. Future plans for another 100MW wind is discussed. At Bornholm an energy island of GW size is planned. In the future The need for curtailment can be mitigated by energy storage systems, large controllable loads or high-capacity interconnects. PowerLabDK host an Enapter electrolyzer, Xolta battery and rooftop PVs, all potential ingredients in a small scale hybrid power plant.

### Task

Investigate and model a laboratory scale hybrid power plant and study the challenges from the electrolyzer production of hydrogen, need for - & size of storage, dynamics, efficiency, auxiliaries demand, communication impact, resilience, cost etc.



## Keywords

- Virtual storage plants
- Modeling & simulation
- PtX technologies
- Experimental hybrid power plants

## Contact & Information

Contact person: Shi You

Mail: [shyo@dtu.dk](mailto:shyo@dtu.dk) or [ctra@dtu.dk](mailto:ctra@dtu.dk)

Division: Power and Energy Systems

Master thesis: X

Bachelor project: X

Can be both: X

# Impact of grounding of Y-Transformers in Offshore Substations on Asymmetrical LVRT and Post-Fault Overvoltage Behavior

**Project Description:** This project investigates how grounding strategies in offshore substations (direct grounded vs impedance grounded Y-transformers) affect the ability of a wind park to respond to asymmetrical LVRT events. The study focuses on overvoltage mitigation (reducing insulation stress on cables and transformers) and symmetrical reactive current support during post-fault temporary overvoltage (TOVs). Students will model both grounding configurations and analyze their influence on system stability and equipment protection.

- Understand Grounding Strategies and LVRT Requirements
  - Explain the role& impact of transformer grounding in offshore substations
  - Describe asymmetrical LVRT and reactive current injection requirements under grid codes.
- Model Electrical Behavior Under Fault Conditions
  - Simulate direct grounded and impedance grounded Y-transformer configurations.
  - Analyze voltage profiles and fault current paths during asymmetrical faults.
- Evaluate Overvoltage and Insulation Stress
  - Assess temporary overvoltages (TOVs) and their impact on cable and transformer insulation.
  - Compare mitigation effectiveness between grounding strategies.
- Analyze Reactive Current Support Post-Fault
  - Quantify symmetrical reactive current injection capability for each grounding method.
  - Recommend optimal grounding strategy for compliance and equipment protection.

## Keywords:

- Asymmetrical LVRT
- Transformers and grounding
- Temporary Overvoltage (TOV)
- Symmetrical Reactive Current Support
- Insulation Stress Mitigation

## Contact & Information

Contact person: Nenad Mijatovic

Mail: [nemi@dtu.dk](mailto:nemi@dtu.dk)

Division: Power and Energy Systems

Master thesis: X

Bachelor project: X

Can be both: X

## Context:

An EV aggregator has the important job of planning and controlling EVs. As the number of EVs are expected to increase, small improvements in control strategies could have a large impact. This, study would investigate the potential of making continuous decisions based on continuously updated forecasts on EV availability, to reduce consumption imbalances and increase earnings from short term intraday markets.

## Objective:

- Establish a running EV forecast
- Utilise forecast to investigate decision making strategies for EV scheduling considering short term energy markets and imbalances
- Evaluate potential improvements

## Outcome:

- EV forecast with continuous capabilities
- Potential profits from improved control strategies

## Keywords:

- Forecasting
- EV
- Scheduling

## Prerequisites

- Python/Julia/Matlab
- Machine learning

## Contact & Information

Contact person: Mathias Botoft Hansen

Mail: [botoft@dtu.dk](mailto:botoft@dtu.dk)

Division: Power and Energy Systems

Master thesis: X

Bachelor project: X

Can be both: X

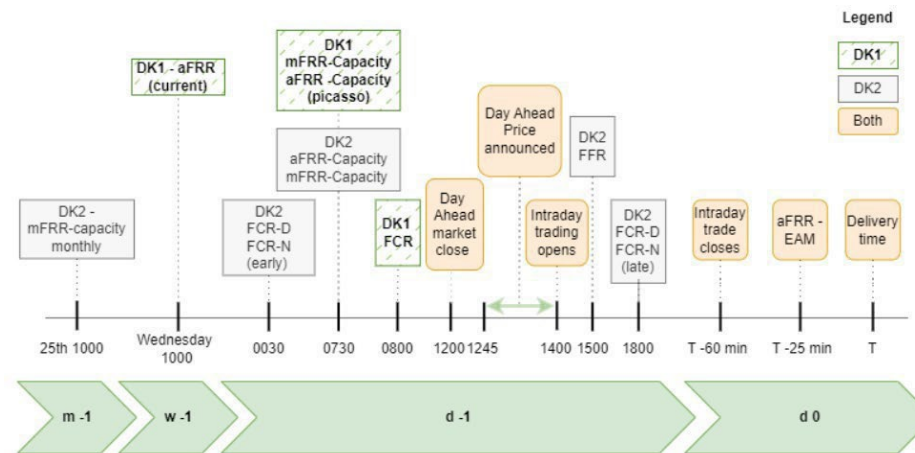

# Investigation of Heterogeneous Behaviour of Second-Life Lithium-Ion Battery Systems

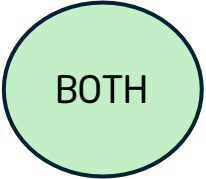

**Research Problem:** The propagation of heterogeneous degradation from retired electric vehicle batteries to second-life systems remains poorly understood, limiting performance prediction and safety assurance in repurposed applications.

**Research Questions:**

How do spatial degradation variations affect current distribution and thermal hotspots in repurposed packs? What relationships exist between automotive cycling history and second-life performance? Can predictive criteria be established for optimal battery sorting based on degradation compatibility?

**Methodology:** This research employs an integrated experimental-computational approach leveraging industry partnerships: Collaboration with NT Energy for characterizing battery packs, validation testing & field applications, and Partnership with Resolvent A/S for advanced analytics and digital twin capabilities. Multi-scale modeling extending PyBaMM with various stress effects and COMSOL-based coupled electrochemical-thermal analysis

**Expected Contributions:**

Novel performance prediction framework linking usage history to degradation modes. Fundamental understanding of degradation interactions in heterogeneous systems. Validated physics-based criteria for optimal battery sorting and configuration. Advanced modeling methodology bridging industry data with academic research

**Resources:** hardware and testing protocols and results; software infrastructure; prior experimental frameworks and datasets; machine learning tools, knowledge of the fundamental battery mechanism and behaviour, battery management systems.

**Keywords**

Heterogeneous Degradation, Battery Management System, Physics-Based Modeling, Data-driven Modeling, Predictive Modeling, Battery Second-Life, Industry-Academia Collaboration, Digital Twin.

**Contact & Information**

Contact person: Chunyang Zhao & Chresten Traeholt

Mail: [chuzh@dtu.dk](mailto:chuzh@dtu.dk) [ctra@dtu.dk](mailto:ctra@dtu.dk)

Division: Power and Energy Systems

Master thesis: X

Bachelor project: X

Can be both: X

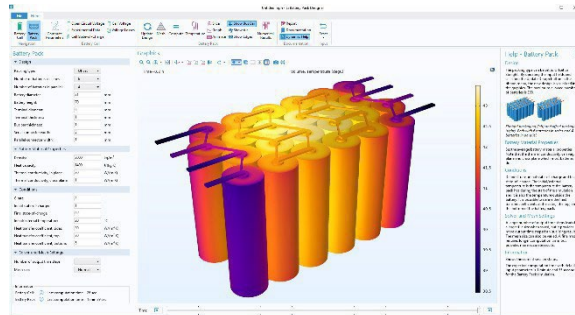
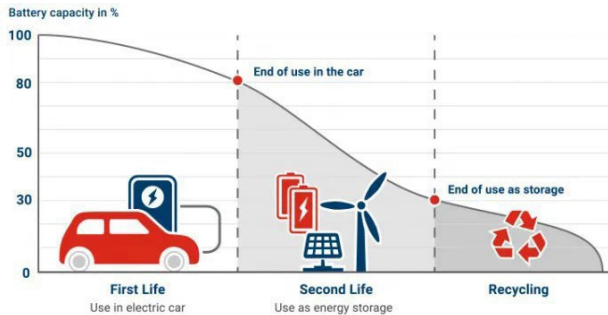



Coordinating the charging processes in **EV clusters** is a hot topic in both research and industry. This task is performed by **load management systems**, which can facilitate different goals:

- Adapt charging power to renewable energy
- Help balance the power system
- Provide peak shaving

## Project tasks:

- Model a **smart charging cluster**: chargers, grid connection, EVs, user behavior
- Develop a management system that can **coordinate** the **charging processes**
- Comparison of **control strategies**
- Optional: Experimental testing of developed approaches in our **smart charging test facilities** (<http://130.226.56.180:8443/svg/>)

## Keywords:

- Electric vehicles (EVs)
- Charging behaviour
- Charging cluster
- Management system

## Contact & Information

Contact person: Jan Engelhardt

Mail: [janen@dtu.dk](mailto:janen@dtu.dk)

Division: Power and Energy Systems

Master thesis: X

Bachelor project: X

Can be both: X

# Modelling residential electricity consumption - assessing modelling choices and data availability

Due to the green transition, transportation and heating are being electrified in Denmark. This drastically alters the consumption patterns for residential consumers in the existing grid, necessitating new models for Distribution System Operators when planning grid expansion, reinforcement, and budgeting. Furthermore, the energy crisis in 2022 introduced a different aspect, namely, price awareness, which resulted in demand-side flexibility in residential consumption. These changes were modeled (Bak2025) for a Danish DSO employing a layered linear model - which is no longer sufficient for capturing the current dynamics.

## Keywords

DSO  
Demand Side Flexibility  
Energy Crisis  
Price Sensitivity

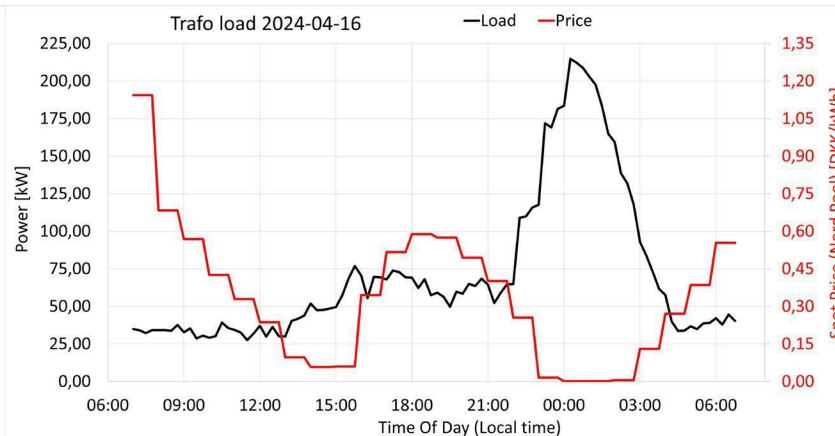
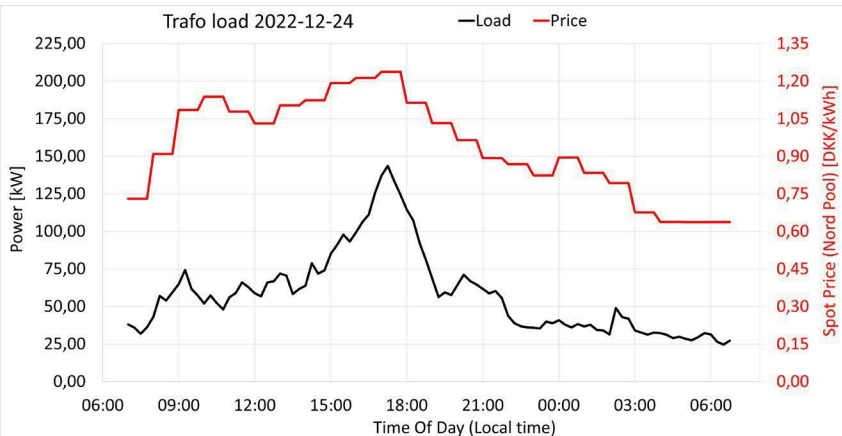

## Contact & Information

Contact person: Bjarke Bak

Mail: [bbak@dtu.dk](mailto:bbak@dtu.dk)

Division: Power and Energy Systems  
& Konstant Net & Green Power DK

Master thesis: X

# New battery concepts and chemistries

BOTH

Short description of the thesis/project idea

## Background

Renewable resources (RES) wind, PV and storage are all components in a future power system. Battery energy storage systems have for a long time been too costly for large scale storage. This is currently changing due to cost reduction, new chemistries and new battery topology and hybrids. A particular challenge is battery state of health monitoring and estimation.

## Task

The main objective of this master thesis project is to test and model the emerging technologies and chemistries such as Na-ion based battery cells, USB chargeable Nitecore,....? Monitoring approaches include  $dV/dq$ , ICA, EIS, etc. and modelling include data driven approaches, machine learning, AI, LLM, etc.

## Industrial opportunity

PowerLaabDK.

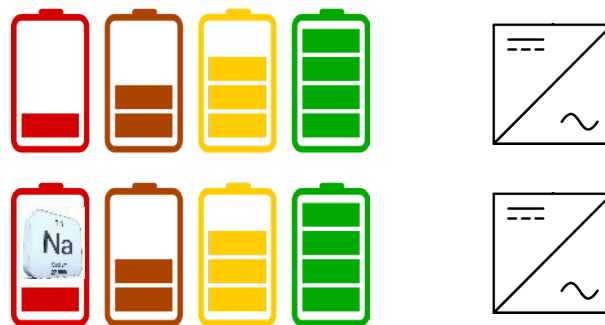

## Keywords

- Battery testing
- Cell & cluster testing
- Cell-power electronics topology



## Contact & Information

Contact person: Shi You

Mail: [shyo@dtu.dk](mailto:shyo@dtu.dk) or [ctra@dtu.dk](mailto:ctra@dtu.dk)

Division: Power and Energy Systems

Master thesis: X

Bachelor project: X

Can be both: X

# Optimal phase allocation of electrification loads given per-phase smart meter data

BOTH

Distribution grids are under pressure from electrification and imbalanced grids have a lot of unused grid capacity, cause grid losses and even local outages. **What if grid operator could automatically tell an electrician via an app, which of the three grid phases currently would be the best to connect a heat pump or EV charger to?** Motivated by this idea we have built a data pipeline leading from smart meter measurements to a three-phase power flow.

This thesis should **develop automatic recommendation techniques to suggest e.g. an electrician to which phase to connect in a given types of electrical equipment in a given electrical low voltage network.** This work is based on prior results which have characterized the observable phase imbalances to identify typical imbalance patterns over time.

The 3PhaseInsight project has access to **a unique data set** of 100k per-phase (3-phase) smart meter measurements. Access to this data set enables to explore the feasibility of novel data-driven methods, and to develop and validate their applicability in a realistic setting. First results already demonstrate how typical assumptions in the academic literature are challenged and that methods can be refined through this data set.

This thesis may be carried out in **collaboration with Radius**, Denmark's largest distribution grid operator (DSO), and responds to a specific need that DSOs will have more and more in the near future.

## Keywords:

Phase imbalance, distribution grid, AI, Smart Metering Data, Residential Consumption

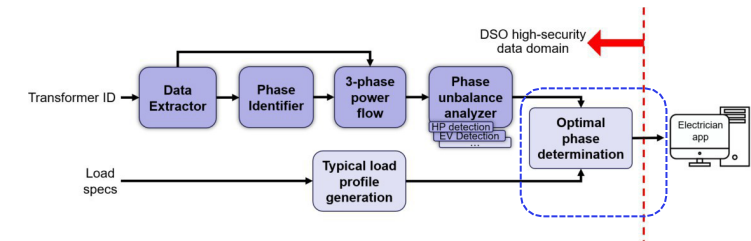

## Contact:

Name: Kai Heussen

Mail: [kheu@dtu.dk](mailto:kheu@dtu.dk)

Division: Power and Energy

Systems & Radius

Master thesis: X

Bachelor project: X

Can be both: X



# Over-current properties of a High Temperature Superconductive cable.

BOTH

Short description of the proposal:

When a High Temperature Superconductive (HTS) cable is installed into the grid and a fault current happens, the cable needs to survive. Through experiments and modelling you will determine the transients of an NKT superconductive cable. Help give industry recommendations and limitations of an HTS cable transient.

- Explain the superconductivity phenomenon.
- Apply an electrical and thermal model to evaluate transients at and above nominal currents for an HTS cable.
- Analyse and compare with experimental data
- Evaluate limits of models and give recommendations on limits of cable.

## Keywords:

Superconductive Cable, HTS cable,

Cryogenic, thermal and electrical model, R&D, HTS, High Voltage Cable, Overcurrent, Work with industry, Cryogenic temperatures, Real World Applications



## Contact & Information

Contact person: Nenad Mijatovic

Mail: [nemi@dtu.dk](mailto:nemi@dtu.dk)

Division: Power and Energy Systems

Master thesis: X

Bachelor project: X

Can be both: X

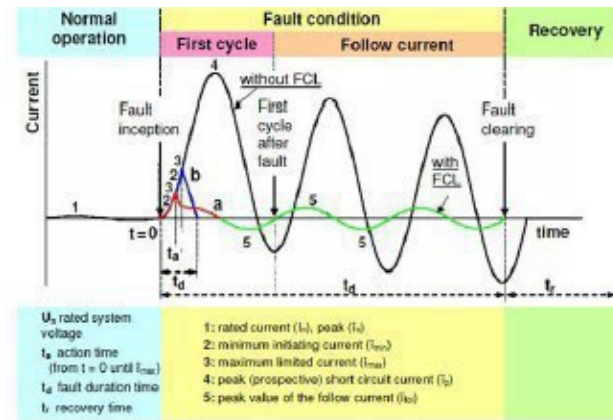

# Performance Evaluation of Aggregated EV Chargers for Ancillary Grid Services

This thesis will analyze data from a large-scale prequalification experiment involving ~1200 EV chargers from multiple vendors. The goal is to evaluate the technical feasibility of using aggregated EV chargers to provide ancillary services, such as aFRR and FCR-D. The student will assess activation speed, response accuracy, compliance with TSO requirements, and discuss this in the context of congestion management in N-1 situations in the DSO grid. The work will contribute to understanding the role of EVs in future grid stability and flexibility markets.

## Key tasks:

- Analyze activation response times and power delivery accuracy.
- Compare performance across charger vendors.
- Benchmark results against TSO ancillary service requirements.
- Identify technical and regulatory gaps for DSO-level services.

The project will contribute to the research project e2flex: <https://wind.dtu.dk/e2flex>

## Keywords

Electric Vehicles (EV)  
Smart Charging  
Ancillary Services  
Aggregated Flexibility  
Grid Stability  
Congestion management  
Demand Response



## Contact & Information

Contact person: Tilman Weckesser  
Haris Ziras  
Mail: [tweck@dtu.dk](mailto:tweck@dtu.dk), [chazi@dtu.dk](mailto:chazi@dtu.dk)  
Division: Power and Energy Systems  
Master thesis: X  
Bachelor project: X  
Can be both: X

# Power cables and joints AC resistance measurement methodology with thermal cycling

BOTH

RELI  
BOND

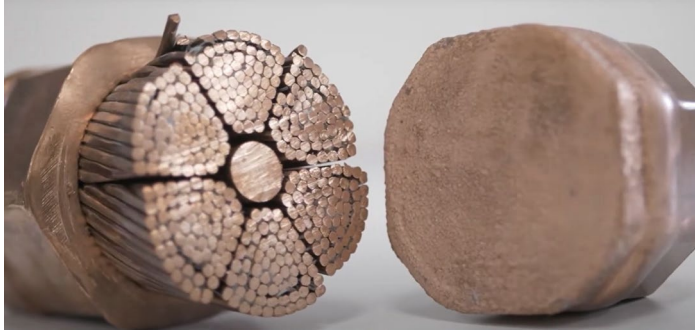

## Short description of the proposal:

Project focuses on study, implementation and advancement of measuring methodology for large cross section power cable online characterization. The methodology should be compatible with thermal cycling.

Tentative tasks:

- Perform literature survey
- Implement several promising methodologies for AC resistance measurements and evaluate its performance against published literature and DC resistance
- Develop the calibration procedure based on well defined structure/conductor
- Potentially: experimental investigation of shear bolt connector performance on large cross section Al conductor (>2000 mm<sup>2</sup>) and comparison with ReliBond Solution
- Project might be suitable for paper for Cigre or Jicable

## Keywords:

Power cables,  
Power cable joints  
FE modeling,  
testing,  
power measurement

## Contact & Information

Contact person: Nenad Mijatovic

Mail: [nemi@dtu.dk](mailto:nemi@dtu.dk)

Division: Power and Energy Systems

Master thesis: X

Bachelor project: X

Can be both: X

# Power cables joints optimization of coating thickness and contact plate

BOTH

RELI  
BOND

## Short description of the proposal:

Project focuses on advancements of FEA study of cable joints accounting for electromagnetic and thermal aspects of design. The study will investigate balance between the fidelity of the models and the model size/complexity. The project will use the knowledge to perform initial optimization of the material structures and/or properties (within the scope of technological feasibility) with objective of minimizing AC resistance

Tentative tasks:

- Perform literature survey
- Explore and qualify the fidelity/complexity of the 2D axisymmetric implementation & 3D models of aluminum Milliken cable joint
- Explore multi-fidelity system approach combining 2D & 3D model implementation of optimal solution
- Benchmark the optimal proposal vs published studies (Cigre) and/or experimental data

## Keywords:

Power cables,  
Power cable joints  
FE modeling,  
testing,  
power measurement

## Contact & Information

Contact person: Nenad Mijatovic

Mail: [nemi@dtu.dk](mailto:nemi@dtu.dk)

Division: Power and Energy Systems

Master thesis: X

Bachelor project: X

Can be both: X

# Predicting frequency reserves with conformal prediction

**Challenge:** Renewable energy in power grids creates **balancing challenges** due to stochastic factors affecting generation

**Context:** Ancillary service and capacity markets were developed to **handle forecast uncertainties**, with the recent adoption of *dynamic dimensioning* replacing static methods

**Main objective:** This project will **investigate new methods to predict reserve capacity** using historical imbalances and Available Transfer Capacity (ATC)

**Approach:** We will explore how a **statistical method called conformal prediction** can be employed to reserve capacity at various times of day, building upon previous static approaches based on maximum reference incidents

**Collaboration:** The work will be **conducted with Energinet**, involving their engineers and data scientists implementing changes in ancillary services

## Keywords

1. Ancillary services
2. **Conformal prediction**
3. Formal guarantees
4. Probabilistic methods
5. **Uncertainty quantification**

## Contact & Information:

Supervisor: Licio Romao

Email: [licio@dtu.dk](mailto:licio@dtu.dk)

Division: Power and Energy Systems

**MSc thesis**

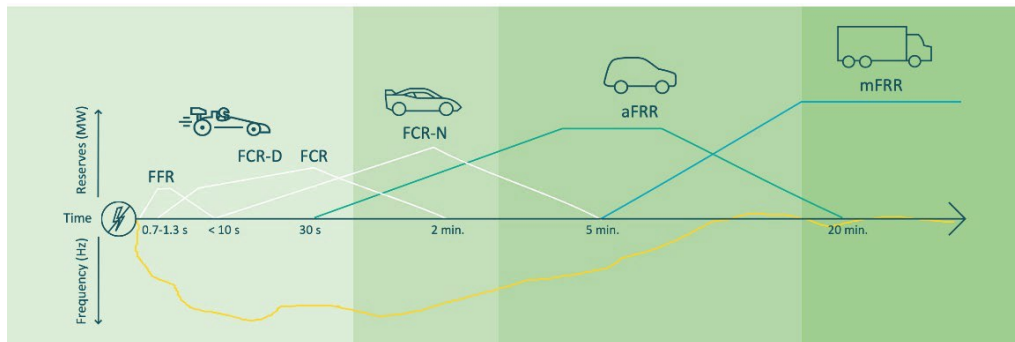

Different frequency services in Denmark ([Energinet](https://www.energinet.dk))

# Real-time frequency control using MPC

**Challenge:** Low-inertia power systems with converter-based generation make frequency control more challenging

**Context:** Virtual inertia can be provided by various energy assets (wind turbines, PV, batteries, synchronous compensators, demand response)

**Main objective:** Explore mathematical and computational tools to model frequency dynamics of low-inertia grids while ensuring probabilistic guarantees for frequency control after large imbalances

**Approach:** Review/explore methods for modeling frequency dynamics in low-inertia systems using open-source software

$$\min_{u_t, \dots, u_{t+N-1}} \left\{ \sum_{k=0}^{N-1} \|y_{t+k} - r(t)\|^2 + \rho \|u_{t+k} - u_r(t)\|^2 \right\}$$

$$s.t. : x_{t+k+1} = f(x_{t+k}, u_{t+k})$$

$$y_{t+k} = g(x_{t+k}, u_{t+k})$$

$$u_{\min} \leq u_{t+k} \leq u_{\max}$$

$$y_{\min} \leq y_{t+k} \leq y_{\max}$$

$$x_t = x(t), k = 0, \dots, N - 1$$

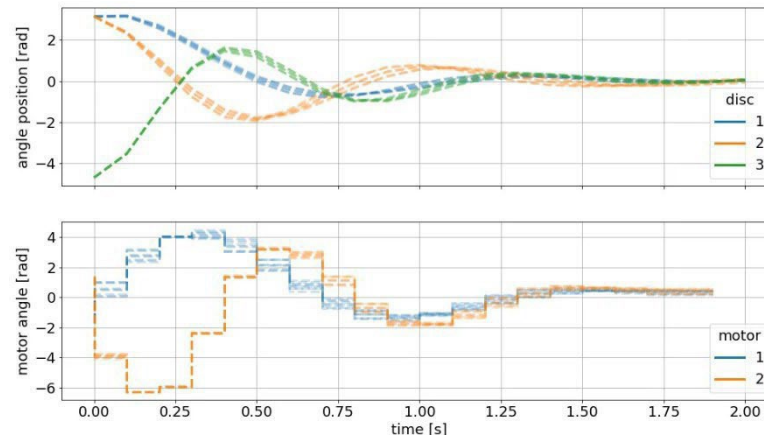

## Keywords:

1. Dynamic frequency control
2. Chance-constrained optimisation
3. Model predictive control
4. Feedback control

## Contact & Information:

Supervisors: Licio Romao and Tilman Wecksser

Email: [licio@dtu.dk](mailto:licio@dtu.dk), [tweck@dtu.dk](mailto:tweck@dtu.dk)

Division: Power and Energy Systems

MSc thesis

# Robust state observers for sensor reduction in drives with sinusoidal filters

## Context and challenge

**Electric drives with sinusoidal output filters** provides several benefits, such as reduce acoustic noise, electromagnetic interference, harmonic content, and losses in cables and machines. However, they also **introduce additional states**, which **increases system complexity, computational load,** and **require additional sensors.**

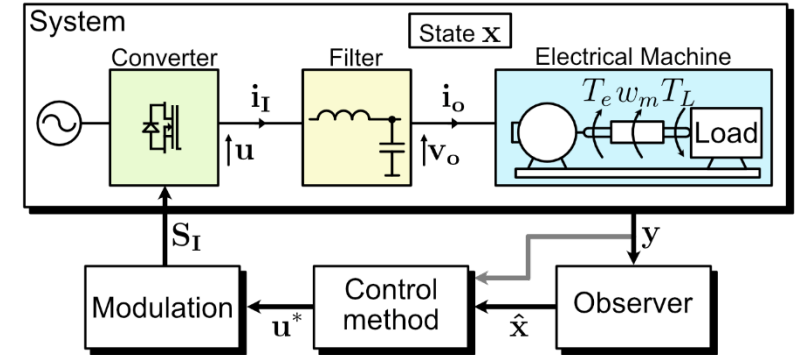
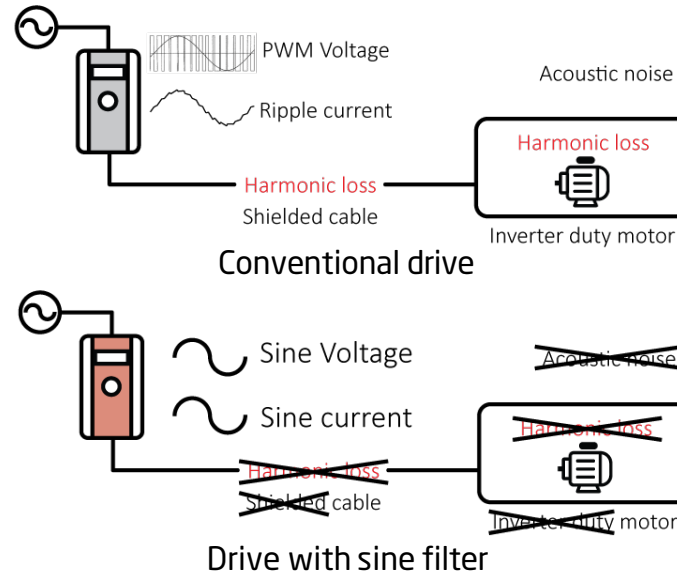

## Keywords

Power converters  
Electric drives  
Sinusoidal filters  
State observers  
Sensorless

**Objective:** Investigate, design and implement robust state observers capable of handling parameter variations, achieving high dynamic performance with low computational burden.

## Project tasks

- Review state-of-the-art observer methods for drives with sine filters.
- Simulate baseline observer methods and identify their main limitations.
- Propose, document, and simulate an enhanced observer method.
- Validate experimentally and compare results.
- Write the master thesis.



Smart converter lab at DTU Lyngby campus

## Contact & Information

Contact person: Miguel Lopez  
Email: [melga@dtu.dk](mailto:melga@dtu.dk)  
Division: Power and Energy Systems  
Master thesis: X

# RTDS PowerLab Power Hardware in Loop experimental setup for testing grid forming converters

BOTH

Project Description: Student will design and implement a PHIL setup using RTDS (Real-Time Digital Simulator) to test grid-following and grid-forming converters (and the switching between two operation modes) under realistic grid conditions. The project emphasizes understanding PHIL principles, RTDS configuration, and converter control strategies for stability and resilience in low-inertia power systems.

- Understand PHIL and Grid-Forming Concepts
  - Explain the principles of Power Hardware-in-the-Loop and its role in validating converter performance.
  - Describe grid-forming control strategies and their importance in renewable-dominated grids.
- Configure RTDS for PHIL Applications
  - Set up RTDS models for grid simulation, including voltage and frequency dynamics.
  - Implement real-time interfaces between RTDS and physical hardware.
- Integrate and Test Grid-Forming Converter Hardware
  - Connect a physical converter to the RTDS environment using appropriate amplifiers and sensors and validate converter response under different grid scenarios (faults, islanding, low inertia).
- Analyze System Performance and Stability
  - Measure key metrics such as voltage stability, frequency support, and fault ride-through capability and compare experimental results with theoretical expectations and simulation-only cases.

## Keywords:

- Power Hardware-in-the-Loop (PHIL)
- RTDS (Real-Time Digital Simulator)
- Grid-Forming Converters
- Low-Inertia Power Systems
- Real-Time Simulation
- Converter Control Strategies
- Experimental Validation

## Contact & Information

Contact person: Nenad Mijatovic

Mail: [nemi@dtu.dk](mailto:nemi@dtu.dk)

Division: Power and Energy Systems

Master thesis: X

Bachelor project: X

Can be both: X

# Sensitivity Study of LVRT with Symmetrical Reactive Current Injection: Impact of Export Cable Length

Project Description: Students will investigate how an offshore wind park (400 MW) can support onshore Low Voltage Ride Through (LVRT) requirements under classical grid codes by injecting symmetrical reactive current during voltage dips. The study will focus on varying export cable lengths (30 km, 60 km, 90 km) and determine the maximum cable length and corresponding voltage level where LVRT compliance is achievable.

- Understand LVRT and Grid Code Requirements
  - Explain the concept of LVRT and its importance for grid stability.
  - Describe symmetrical reactive current injection and its role during voltage dips.
- Model Offshore Wind Park and Export Cable Dynamics
  - Develop a simplified model of a 400 MW offshore wind park connected via export cables.
  - Incorporate cable impedance and reactive power capability into the model.
- Perform Sensitivity Analysis
  - Simulate LVRT scenarios for 30 km, 60 km, and 90 km cable lengths.
  - Identify the limit of cable length and voltage level for LVRT compliance.
- Analyze Results and Recommend Design Guidelines
  - Compare reactive current injection performance across cases.
  - Provide recommendations for cable length and park configuration to meet grid codes.

## Keywords:

- Low Voltage Ride Through (LVRT)
- Symmetrical Reactive Current Injection
- Offshore Wind Park
- Grid Code Compliance
- Reactive Power Support
- Voltage Stability Analysis

## Contact & Information

Contact person: Nenad Mijatovic

Mail: [nemi@dtu.dk](mailto:nemi@dtu.dk)

Division: Power and Energy Systems

Master thesis: X

Bachelor project: X

Can be both: X

## 1 High Power Lab

High power testing of electrical components and installations

- Tests laboratory designed for conducting 1, 2 or 3-phased short-circuit tests; with short-circuit currents up to 50 kA in 1 second
- Supply voltage up to 3 x 690 V
- Measurement at very high accuracy in multiple channels
- Test of large equipment objects up to 4 m x 4 m

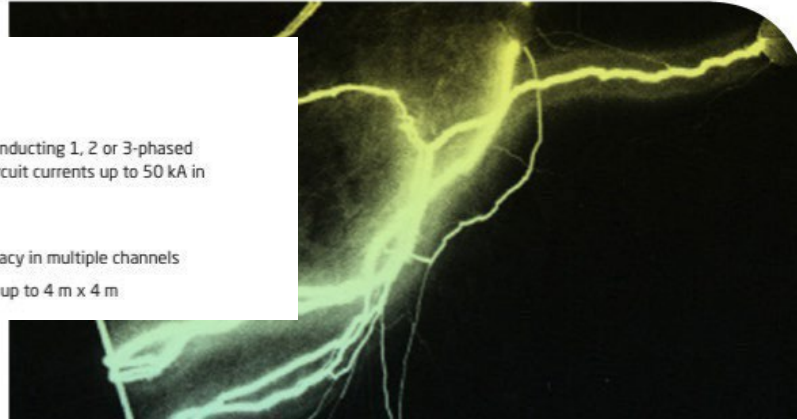

### Keywords:

Short circuit testing standards (like Cigre TB894 ), experiment automatization, FE modeling, design of experiments and experimental validation

Investigation area could include:

- Study of short circuit test standards in power system (Cigre TB894 and similar)
- Investigation of experimental capabilities of High Power Lab
- Characterization of the existing measurement and logging system
- Planning and execution of up to 10 short circuits tests
- Design study and optimization of the current boosting transformer
- Design study and optimization of the high current rectifier for DC system testing

### Contact & Information

Contact person: Nenad Mijatovic  
Mail: [nemi@dtu.dk](mailto:nemi@dtu.dk)  
Division: Power and Energy Systems  
Master thesis: X  
Bachelor project: X  
Can be both: X

# Study of Anti-lock Braking (ABS) System Using Additive Manufacturing and Standard Components suitable for FS

**Project Description:** This project introduces students to the core principles of ABS, including wheel slip control and hydraulic pressure modulation. Students will attempt the design a simplified ABS functionality (valve block), manufacture it using additive techniques, and integrate standardized electro-valves and a pump to demonstrate basic ABS functionality on a test rig.

- **Understand ABS Fundamentals and perform State of the Art (SoA) review**
  - Explain wheel slip, braking dynamics, and how ABS improves safety and stability
  - Describe the basic hydraulic & electronic architecture of ABS
- **Design a Simplified ABS Valve Block based the SoA**
  - Create CAD/FEA optimized model for additive manufacturing & ensure proper flow paths and mounting for electro-valves and pump
- **Prototype Manufacturing and Assembly**
  - Select suitable materials and 3D printing processes for hydraulic components
  - Assemble the valve block with standardized electro-valves and pump.
- **Optional: Functional Testing and Performance Analysis**
  - Build a simple brake test rig to demonstrate pressure modulation.
  - Evaluate prototype performance against expected ABS behavior

## Keywords:

Electronic Stability Control  
Driver-in-the-Loop  
Real-Time Vehicle Simulator  
Vehicle physics  
Tyre mathematical model

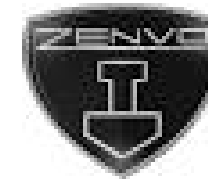

## Contact & Information

Contact person: Nenad Mijatovic  
Mail: [nemi@dtu.dk](mailto:nemi@dtu.dk)  
Division: Power and Energy Systems  
Master thesis: X  
Bachelor project: X  
Can be both: X

# User-oriented Smart Meter Data Value Creation

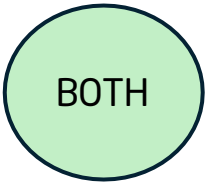

Distribution grids are under pressure from electrification and imbalanced grids have a lot of unused grid capacity, cause grid losses and even local outages. **What if grid operator could automatically tell an electrician via an app, which of the three grid phases currently would be the best to connect a heat pump or EV charger to?** Motivated by this idea we have built a data pipeline exploiting smart meter measurements.

This thesis **should investigate several ways in which potential end-users, such as DSOs, consumers, or electricians would benefit from having insights generated from their smart meter data**, that could be shared by the DSO. A simple data-app to show-case the user interaction and interview-based assessment of user feedback would be relevant for this project. This work is based on prior results that provide meaningful inputs to such an app.

The 3PhaseInsight project has access to **a unique data set** of 100k per-phase (3-phase) smart meter measurements. Access to this data set enables to explore the feasibility of novel data-driven methods, and to develop and validate their applicability in a realistic setting. First results already demonstrate how typical assumptions in the academic literature are challenged and that methods can be refined through this data set.

This thesis may be carried out in **collaboration with Radius**, Denmark's largest distribution grid operator (DSO), and responds to a specific need that DSOs will have more and more in the near future.

## Keywords:

Phase imbalance, distribution grid, AI, Smart Metering Data, Residential Consumption

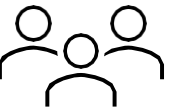
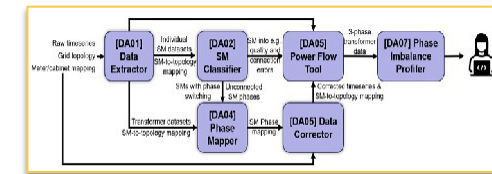
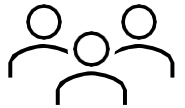
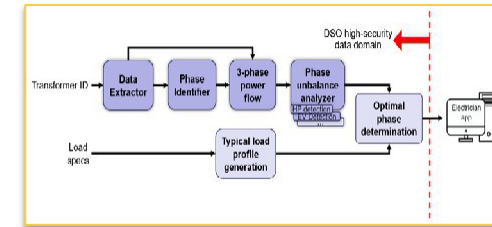

## Contact:

Name: Kai Heussen

Mail: [kheu@dtu.dk](mailto:kheu@dtu.dk)

Division: Power and Energy Systems & Radius

Master thesis: X

Bachelor project: X

Can be both: X



# Zero inertia power systems

Short description of the thesis/project idea

## Background

Power systems based on renewable resources (RES) wind, PV and battery energy storage systems (BESS) are characterized by being converter dominated and exhibiting very low inertia. A particular challenge is the loss of short circuit capabilities (fault current and short circuit power) and the apparent need for increasingly fast converter control to maintain grid stability, avoid voltage dips, and ultimately grid collapse.

## Task

The main objective of this master thesis project theoretical and is to explore (model & simulation) and challenge the fundamental principles of optimal power flow and system stability. Questions to explore: Is droop control optimal, how to mitigate the need for ever faster control, is a fixed frequency the optimal control objective, is it possible to formulate new operational principles for zero-inertia grids?

## Industrial opportunity

XX.

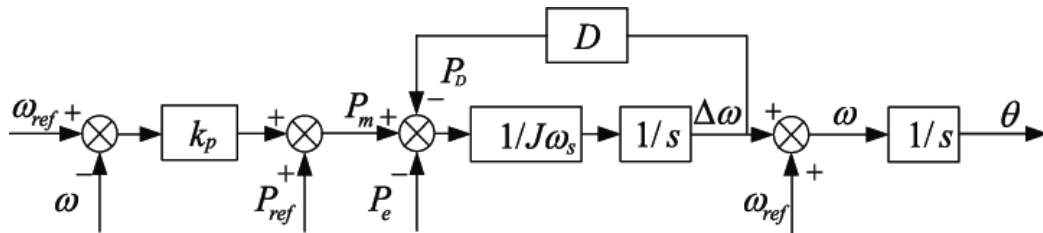

## Keywords

- Converter dominated systems
- Zero inertia
- Control theory
- Grid stability
- Grid modelling & simulation
- Transient grid simulation

$$\frac{2H_{EQ}}{\omega_s} \frac{d^2 \delta}{dt^2} = P_{mecEQ} - P_{elecEQ}$$

## Contact & Information

Contact person: Shi You

Mail: [shyo@dtu.dk](mailto:shyo@dtu.dk) or [ctra@dtu.dk](mailto:ctra@dtu.dk)

Division: Power and Energy Systems

Master thesis: X

Bachelor project: X

Can be both: X

## Renewable Energy Generation

Wind park layout & operation

Wind farm control

Hybrid Power Plant design, incl. PtX

Balancing services of RES

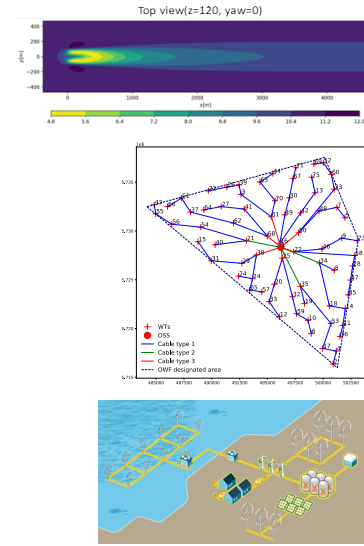

## Renewable Energy Resources

Wind resource modelling

Wind resource software

Correlated wind, solar and hydro resource modelling

Flow, turbulence modelling

Satellite remote sensing

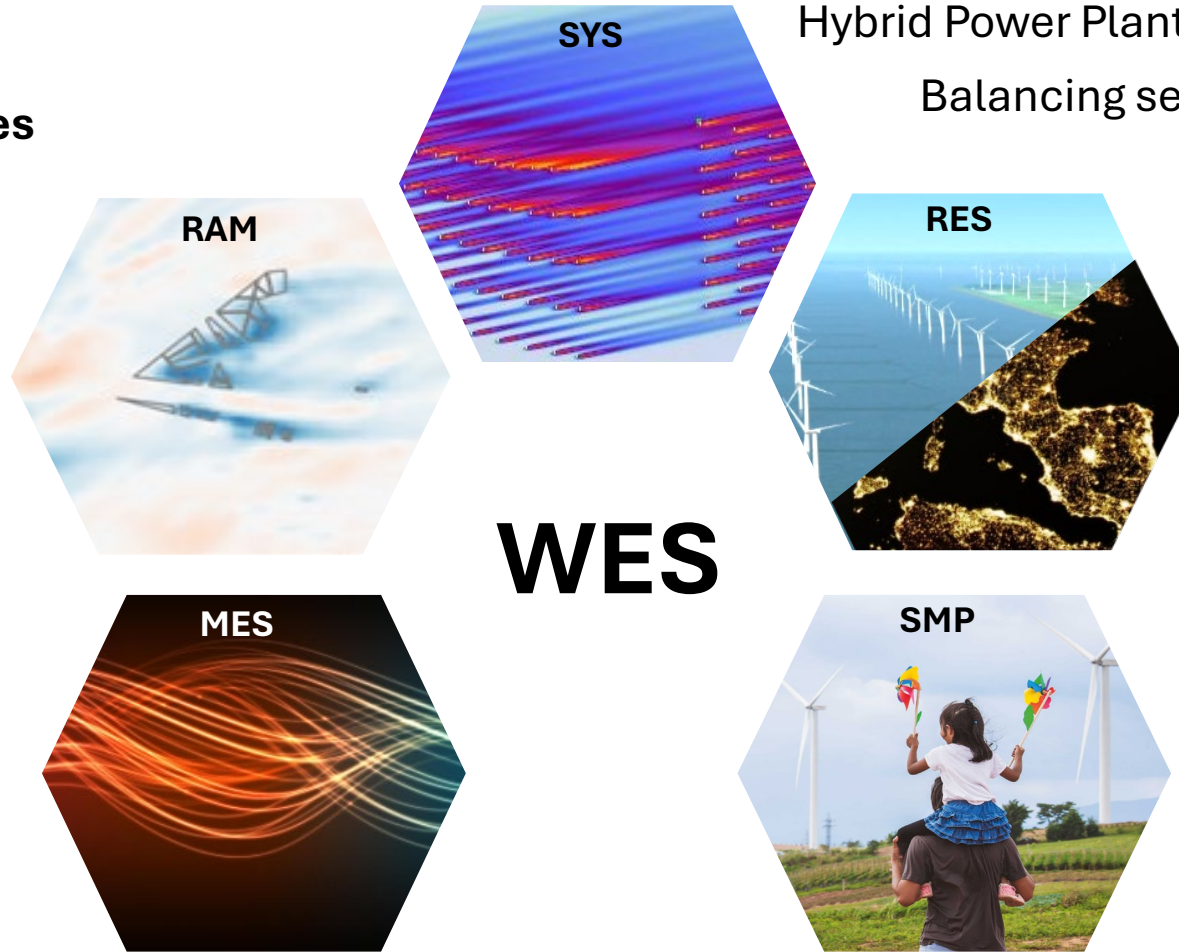

## Energy Systems

System integration of RES

Long-term production modelling

Long-term scenarios, energy mix & system planning

## Societal Context

Social acceptance

Economic and policy issues

Environmental issues

Global supply chains & industrialisation

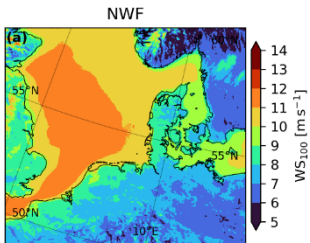

Social acceptance is a critical factor to enabling future wind deployment but is typically considered for individual projects, making it difficult to incorporate into energy system planning tools or other cross-cutting impact assessments. This project will develop a spatially resolved model to estimate the likelihood of success of future wind projects based on publicly available datasets in Denmark, Germany, the UK, or another EU- or EU-adjacent countries (ie, local demographics, political data). One possible approach could be to develop a regression or AI/ML model to correlate spatial data with historic data on wind project acceptance, and to use this model to anticipate future trends. Alternatively, the project could attempt to draw from the literature on social acceptance and to explore how to connect existing studies on a broad spatial scale. The project will develop a suitable output metric for the model, i.e., a sliding scale of likelihood of public acceptance, risk or negative impacts, etc., that can be calculated spatially. These model results will be geographically mapped to the renewable resource zones used in DTU energy sector models (Balmorel and/or PyPSA) to provide an indicator of likely public acceptance or resistance in capacity expansion planning. These layers will subsequently be used as part of a multi- objective optimization that evaluates tradeoffs between least cost and likelihood of social acceptance (although this is not likely to be within scope for the Masters thesis). The project should also explore if the model can be extended to other EU countries.

## Keywords

Keywords:

Social acceptance

Model development

Spatial analysis

Impact assessment

## Contact & Information

Contact person: Matt Shields Mail:

[msh@dtu.dk](mailto:msh@dtu.dk) Division: Wind

Energy Systems

Master thesis: X

Airborne Wind Energy (AWE) is a technology that utilizes autonomous tethered aircraft to extract energy from the wind. This technology utilizes high altitude wind, that tends to be stronger and more consistent. Additionally, with conventional wind turbines getting larger, so these high-altitude winds are relevant for conventional wind. Thus, there a strong interest to gain more information on high altitude flows.

This project will investigate the application of AWE as a sensor. Sensors can be installed on the aircraft, or the actual dynamics of the aircraft itself can be used to extract information. The project can investigate the implementation or applications:

- Using sensor fusion and digital twin technology to extract data
- Utilizing data for wind resource assessment or control

Other solutions, like laser anemometry, has large measurement volumes and cannot collect temperature or pressure. Untethered drones cannot stay on station like tethered aircraft. Tall towers are expensive. Thus, AWE can provide valuable information that is difficult for current technology.

Project details created in discussion with Michael McWilliam ([mimc@dtu.dk](mailto:mimc@dtu.dk)) and Mark C. Kelly ([mkel@dtu.dk](mailto:mkel@dtu.dk)).



## Keywords

- Airborne Wind Energy
- Meteorology
- Digital Twins/Sensor Fusion
- asd
- Unsteady Flows

## Contact & Information

Contact person: Michael K. McWilliam  
Mark Kelly ([mkel@dtu.dk](mailto:mkel@dtu.dk))  
Mail: [mimc@dtu.dk](mailto:mimc@dtu.dk)  
Division: Wind Energy Systems  
Master thesis: X  
Bachelor project: X  
Can be both: X

# Analyzing the Impact of Price Variability on Wind Power Revenues

Weather-driven fluctuations in wind generation affect not only output but also the timing and value of electricity sold on the market. As renewable shares grow, understanding how weather patterns interact with hourly price dynamics is key to assessing revenue volatility, curtailment risks, and the value of flexibility.

This project examines how different weather years influence wind power revenues in current and future energy systems.

## Student Tasks:

- Analyse the capability energy system models (e.g., Balmorel or PyPSA) to simulate electricity price variability
- Assess resulting wind revenue variability
- Analyse how new turbine designs can improve and stabilise revenues

## Contact & Information

Matti Koivisto, Rujie Zhu  
 Mail: [mkoi@dtu.dk](mailto:mkoi@dtu.dk), [ruzhu@dtu.dk](mailto:ruzhu@dtu.dk)  
 Division: Wind Energy Systems  
 Master thesis: X

## Requirements:

- Basic Python programming
- Basic statistics/data analysis

## Keywords:

- Weather variability
- Price volatility
- Wind generation
- Profitability
- Price variability



# Assessing the Impact of Weather Variability on the Profitability of Wind Investments

Weather variability significantly influences the profitability of wind energy investments. Fluctuations in wind patterns affect generation potential, market prices, system flexibility needs, and the value of storage. As energy systems shift toward higher shares of renewables, understanding how weather data impacts investment outcomes becomes increasingly important.

This project explores how different weather time series affect the economic performance of wind power investments in future energy systems.

## Student Tasks:

- Analyze existing energy system scenarios and hourly prices (already available) toward 2050 across multiple scenarios and 40+ weather years
- Evaluate how weather variability affects wind investment profitability, market revenues and curtailment
- Assess the potential of novel wind turbine designs to improve profitability

## Contact & Information

Matti Koivisto:

Mail: [mkoj@dtu.dk](mailto:mkoj@dtu.dk)

Division: Wind Energy Systems

Master thesis: X

## Requirements:

- Basic Python programming
- Basic statistics/data analysis

## Keywords:

- Weather variability
- Price volatility
- Wind generation
- Profitability
- Energy systems

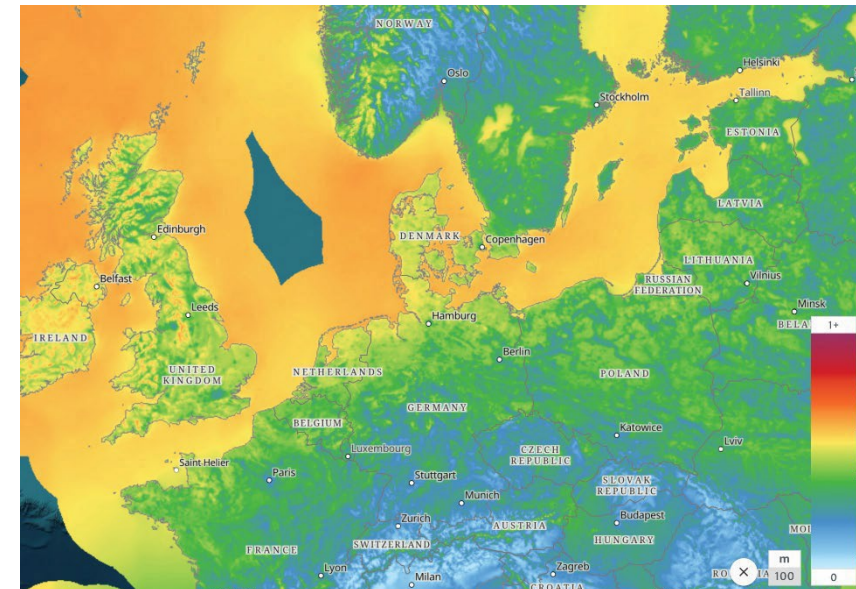

Source: Global Wind Atlas (<https://globalwindatlas.info/en/>)

# Assessing the impact of wind direction variability on the modelling the wake characteristics

## Short description of the project

The wind direction fluctuations that occur within periods of 10-minutes introduce an uncertainty on the wake characteristics that are predicted by wake models. In this project the variations of the wind direction in relation to the mean yaw direction of a utility scale wind turbine is going to be studied. The wind turbine has a rotor diameter of 52 m and it is in the Risø campus of DTU (see photograph). The **learning objectives** of this project are to **analyze** wind turbine and meteorological mast data to **assess** the variability of the wind direction during different periods and investigate the impact of those variations on the wake characteristics using simple wake models.



### Figure

*Photograph of the V52 wind turbine which is located in the Risø campus. In the background it is visible the meteorological mast which will be used in this project to provide high frequency observations of the wind direction fluctuation*

## Keywords:

- Wind direction
- Yaw direction
- Wind turbine
- Wake model
- Observations

## Contact & Information

Contact person: Alfredo Peña /  
Nikolas Angelou

Mail: [aldi@dtu.dk](mailto:aldi@dtu.dk) / [nang@dtu.dk](mailto:nang@dtu.dk)

Division: Wind and Energy System

Master thesis: X

Bachelor project: X

Can be both: X

# Benchmarking and hybridization of search and evolutionary algorithms for wind farm layout optimization

Wind farm (WF) layout optimization is to find the optimal positions of wind turbines (WTs) inside a WF, so as to maximize and/or minimize a single objective or multiple objectives, while satisfying certain constraints. Various search and evolutionary algorithms, such as Random Search (RS), Genetic Algorithm (GA), Particle Swarm Optimization (PSO), Ant Colony Optimization (ACO), has been used to solve the wind farm layout optimization. This project aims to benchmark the performance of several commonly used search and evolutionary algorithms for some realistic wind farm layout optimization cases, also investigate the potential of hybridization of two or more algorithms. PyWake will be used to simulate the flow and calculate the AEP of wind farms.

## Contact & Information

Contact person: Ju Feng ([jufen@dtu.dk](mailto:jufen@dtu.dk))  
Division/Company: Wind Energy Systems  
Master thesis: X

**Keywords:** Wind farm layout optimization, search and evolutionary algorithms, hybridization of algorithms.

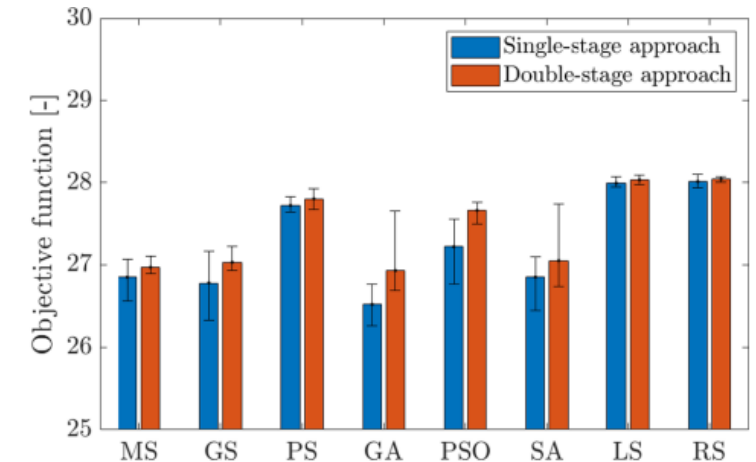

Fig. 13. Comparison of results using single and double-stage approaches. The mean value along with the minimum and maximum are displayed for each algorithm.

[Ref] R. Brogna, et al., "A new wake model and comparison of eight algorithms for layout optimization of wind farms in complex terrain", Applied Energy, (2020), **259**, 114189

With conventional plants retiring, black start provision becomes a growing concern. This thesis would examine how different regions approach black start services, and model the potential for battery systems to contribute. Comparative analysis of procurement strategies and techno-economic modelling would highlight pathways for renewable-based black start solutions.

## Keywords:

Black start services, system restoration, storage-based black start, wind power black start, hybrid systems, ancillary services, system security, Nordic/UK/Australia comparison, resilience modelling

## Contact & Information

Contact person: Zeenat Hameed,  
Chresten Træholt, Zoltan Pinter  
Mail: [zeeha@dtu.dk](mailto:zeeha@dtu.dk)  
Division: ind and Energy Systems  
Master thesis: X

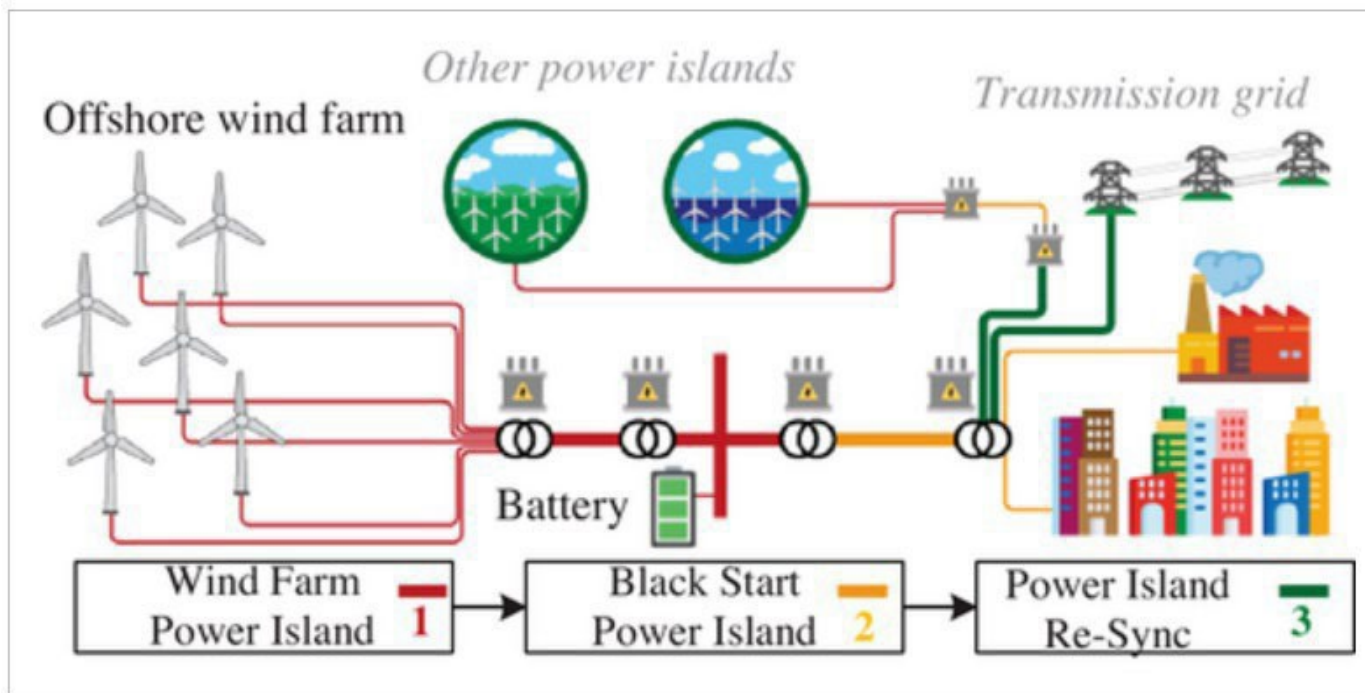

Can one account for the effect of stability within the neutral Mann-model for turbulence, equivalent to the buoyancy-enhanced version?

*[Kelly,2018 hints at such]*

Can involve:

- Testing input parameter space for Mann-model of turbulence
  - neutral vs. buoyant version
- mapping neutral inputs to buoyant ones
  - finding new forms
- Stability-dependence of Mann-model lengthscale
  - other parameters also

## Keywords

- turbulence
- spectra
- stability
- IEC / standards

## Contact & Information

Contact person: Mark Kelly  
(+ J.Mann, G.Larsen)

Mail: [MKEL@dtu.dk](mailto:MKEL@dtu.dk)

Division: Wind and Energy Systems  
Master thesis project: X

# Comparative Modelling of Ancillary Service Markets in High-Renewable Power Systems

This thesis would explore how ancillary service markets are designed in the Nordics, UK, and Australia, focusing on services like frequency containment, and reserve products. The project would investigate whether these markets can be represented within a unified modelling framework and what design lessons can be transferred between regions.

## Keywords:

Ancillary services, frequency response, inertia markets, Nordic power system, UK electricity market, Australian NEM, market harmonization, flexibility markets, high-renewable integration

Services	Australia	California	Nordics	United Kingdom
Pre-fault-raise	Regulation Raise	Regulation Up	Frequency Control Normal Operation (FCR-N)	Dynamic Regulation Dynamic Moderation
Pre-fault-lower	Regulation Lower	Regulation Down	Frequency Control Normal Operation (FCR-N)	Dynamic Regulation Dynamic Moderation
Post-fault-raise	Fast Raise Slow Raise Delayed Raise	Spinning Reserves Non-Spinning Reserves	Frequency Control Disturbed Operation (FCR-D)	Static frequency response Low Frequency Static
Post-fault-lower	Fast Lower Slow Lower Delayed Lower	Not applicable	Frequency Control Disturbed Operation (FCR-D)	Static frequency response Low Frequency Static
Post-fault-fast	Very fast frequency control ancillary service (FCAS)	Not applicable	Fast Frequency Response (FFR)	Dynamic Containment (DC)

## Contact & Information

Contact person: Zeenat Hameed, Chresten Træholt, Zoltan Pinter

Mail: [zeeha@dtu.dk](mailto:zeeha@dtu.dk)

Division: Wind and Energy Systems  
Master thesis. X

# Comparison of flow predictions between static and dynamic wake models

Optimizing wind farm operations, through techniques like flow control and condition monitoring, is crucial for enhancing efficiency and reducing wind power generation costs. A key aspect of this optimization is accurate and cost-effective wake flow modeling under varying inflow conditions. Achieving this often requires a combination of low-fidelity and mid-fidelity models to facilitate optimization and surrogate model generation processes.

This thesis aims to compare the flow predictions of steady-state low-fidelity models, such as those in the PyWake suite [1], with the predictions from the dynamic wake meandering model [2], commonly used in full aeroelastic simulations. The in-house simulation framework, Dynamiks [3], will be employed to apply these models to various relative turbine positions. Predictions for single, partial, and overlapping wakes - for both flow aligned and misaligned turbines - will be compared across a range of tunable parameters and inflow conditions.

The goal is to quantify the relative differences in resulting flow characteristics, such as wake deficit magnitude, wake position, and turbulence intensity.

1 PyWake <https://topfarm.pages.windenergy.dtu.dk/PyWake/>

2 Madsen, H. Aa., Larsen, G. C., Larsen, T. J., Troldborg, N., & Mikkelsen, R. (2010). Calibration and Validation of the Dynamic Wake Meandering Model for Implementation in an Aeroelastic Code. In Journal of Solar Energy Engineering (Vol. 132, Issue 4). ASME International. <https://doi.org/10.1115/1.4002555>

[3] Dynamiks simulation framework <https://dynamiks.pages.windenergy.dtu.dk/dynamiks/notebooks/Overview.html>

Keywords: wake aerodynamics, wind farm flow, static and dynamic wake modeling

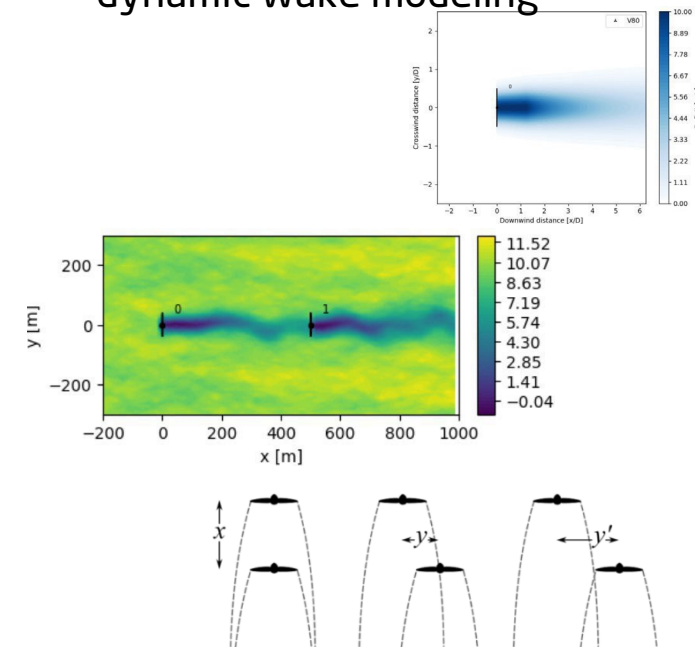

## Contact:

Contact: Vasilis Pettas, Julia Steiner

Mail: [vaspas@dtu.dk](mailto:vaspas@dtu.dk),

[julstei@dtu.dk](mailto:julstei@dtu.dk)

Division: Wind Energy Systems

Master thesis: X

# Complex terrain: replacing RIX with effective roughness

Our new formulation for effective roughness  $\langle h_{sfc} \rangle$  accounts for hill-induced terrain drag.

- How does it improve on the “old” RIX corrections? Aspects to consider can include:
  - geostrophic speed ratios vs.  $\Delta U(\text{RIX})$
  - variation per direction
  - statistics of  $\langle h_{sfc} \rangle$  correction per terrain
    - map resolution impact
    - effect on WRF output or RANS input

Involves:

- Statistical analysis of terrain elevation
- Spectral analysis for microscale modelling
- improvement of WAsP in complex terrain

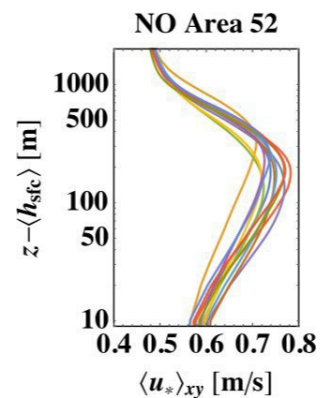
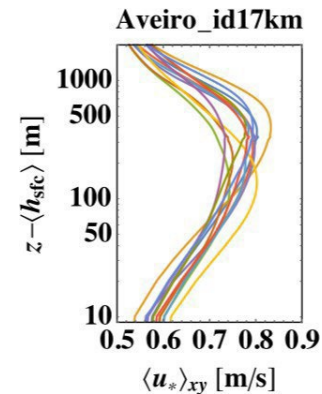

## Keywords

- Microscale modelling
- Spectra & filtering
- Resolution
- Surface description
- Wind resources

## Contact & Information

Contact person: Mark Kelly

Mail: [MKEL@dtu.dk](mailto:MKEL@dtu.dk)

Division: Wind and Energy Systems

Master thesis project: X

The “top” of the atmospheric boundary layer [ABL] affects the wind, especially for shallow ABL's.

- What do WRF statistics for ABL depth look like?
- How does this vary for commonly-used WRF boundary-layer schemes?
- How does this compare to observed bulk statistics?
- How does the above vary per flow regime/place?
  - how does it affect the modelled wind?

Involves:

- Mesoscale model output
- Statistics
- Stability

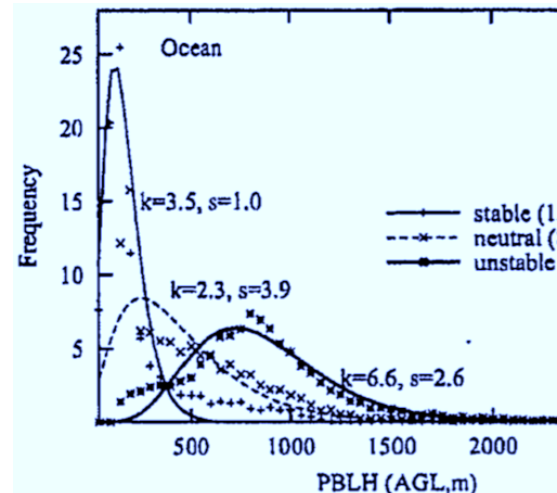

## Keywords

- Mesoscale model
- Statistical analysis
- Atmospheric Stability
- WRF

## Contact & Information

Contact person: Mark Kelly

Mail: [MKEL@dtu.dk](mailto:MKEL@dtu.dk)

Division: Wind and Energy Systems

Master thesis project: X

# Design of hybrid power plants consisting of wind, solar with multiple storage options

The project aims to develop and assess how to operate a hybrid power plant (HPP) with multiple energy storage options (battery, hydrogen, pumped hydro, etc.) to serve a constant load. The design objective could be maximizing profitability, minimizing variability, etc. The students are expected to apply mathematical and/or heuristic optimization methods for the sizing and operations.

The student is expected to perform the following tasks:

- Perform review of the state of the art of energy storage options
- Familiarization with the tool [HyDesign](#)
- Mathematical modelling of an HPP operation with different storage options
- Modeling of HPP to serve a constant load
- Implementation and case studies based on realistic cases

Possible Collaboration Partners -Vattenfall, Ørsted, TotalEnergies, NREL, among others

## Keywords

Optimization, mathematical modelling, Hybrid power plants, energy storage technologies

## Contact & Information

Contact person: Megha Gupta

Mail: [gupta@dtu.dk](mailto:gupta@dtu.dk)

Division: Wind Energy Systems

Master thesis: X

What are the geostrophic drag-law constants implied by commonly-used mesoscale (WRF) configurations, or re-analysis (e.g. ERA5)?

How can we account for this to improve use of mesoscale data in wind resource assessment?

- Involves:
  - Inferring geostrophic drag-law constants
  - Using common WRF PBL-scheme output, idealized/simple cases
  - resolution (sensitivity)
  - effective roughness
  - improving generalization

(can be followed up by either WAsP or CFD use in another work)

## Keywords

- Mesoscale model output use
- Microscale/WAsP input use
- Boundary-layer meteorology
- Resolution
- Roughness
- Resource assessment

## Contact & Information

Contact person: Mark Kelly

Mail: [MKEL@dtu.dk](mailto:MKEL@dtu.dk)

(+ Rogier Floors, Andrea Hahmann)

Division: Wind and Energy Systems

Master thesis project: X

CargoKite is developing a fleet of small, highly flexible cargo ships to revolutionize maritime transport. To make these ships economically feasible (and at the same time reduce our environmental impact) we will harness the wind power with a traction kite to reduce fuel costs and thus CO<sub>2</sub> emissions.

While refining the design of our ship and the kite over the next month, important questions will arise around the dynamic interaction of the kite with the ship:

- How will the varying kite line tension and line direction (from the dynamic flight path as well as varying wind speeds) impact ship motions?
- Do we need to arrange for dynamic ship controls (engine and rudder) to counter kite forces and keep the ship on a steady trajectory?

The successful candidate for this project will develop a coupled model (Matlab/Simulink, Python), linking kite and ship dynamic motions. We will start from first principles and basic models and will successfully increase the level of detail to be able to run test cases and study the system behaviour with increasing level of confidence. Depending on project progress and necessity, a validation campaign with our 24m prototype based in Lisbon, Portugal, can be envisioned.

CargoKite is based in Munich, Germany. The project can be conducted remotely.

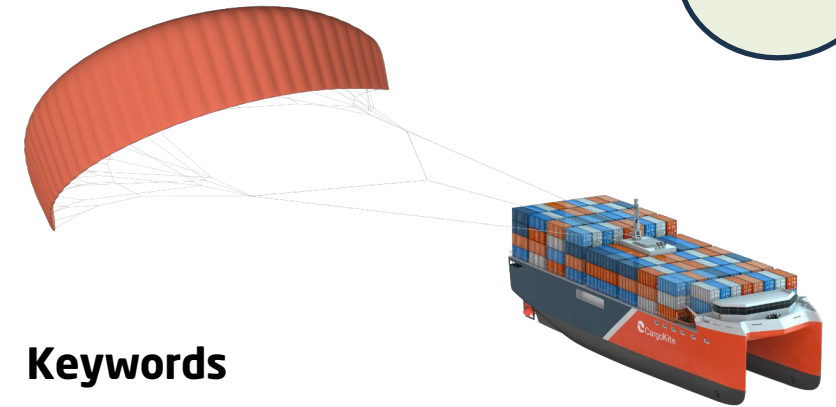

## Keywords

- Maritime Engineering
- Aerodynamics
- Sails
- Wind Propulsion
- Programming (Matlab/Python)

## Contact & Information

Contact person: Michael K. McWilliam

Mail: [mimc@dtu.dk](mailto:mimc@dtu.dk)

Manuel Fluck ([manuel@cargokite.co](mailto:manuel@cargokite.co))

Division: Wind Energy Systems

Master thesis: X

Bachelor project: X

Can be both: X

With the growing popularity of Artificial Intelligence, countries, companies and even individuals invest into data centers. This means a large burden on the electricity grid. We investigate the scenario of PVs, batteries and data centers as a hybrid system, with enhancing self-sufficiency, and potentially using the batteries for ancillary services as well.

The expected outcomes of the master thesis:

- Modelling the data centers as loads for the power system in Simulink.
- Designing a Simscape simulation of the distribution of data centers in a region in Denmark / other parts of the world.
- Introducing battery and PV systems to the simulation.
- Designing optimal energy management for the grid and for the data center owner.
- Potentially, investigating possible business cases of such updates.

## Keywords:

Data centers

Energy Management

## Prerequisites

Basic knowledge of power systems

SimScape or similar

Optimization concepts

## Contact & Information

Contact person: Zoltan Pinter, Zeenat Hameed, Chresten Træholt

Mail: [pinzo@dtu.dk](mailto:pinzo@dtu.dk)

Division: Wind and Energy Systems

Master thesis: X

This project would simulate scenarios of large-scale electric vehicle uptake across the UK, Nordics, and Australian NEM. The focus would be on quantifying how much EV penetration each market can absorb without major reinforcements, and how pricing/tariff structures and flexibility incentives could extend these limits.

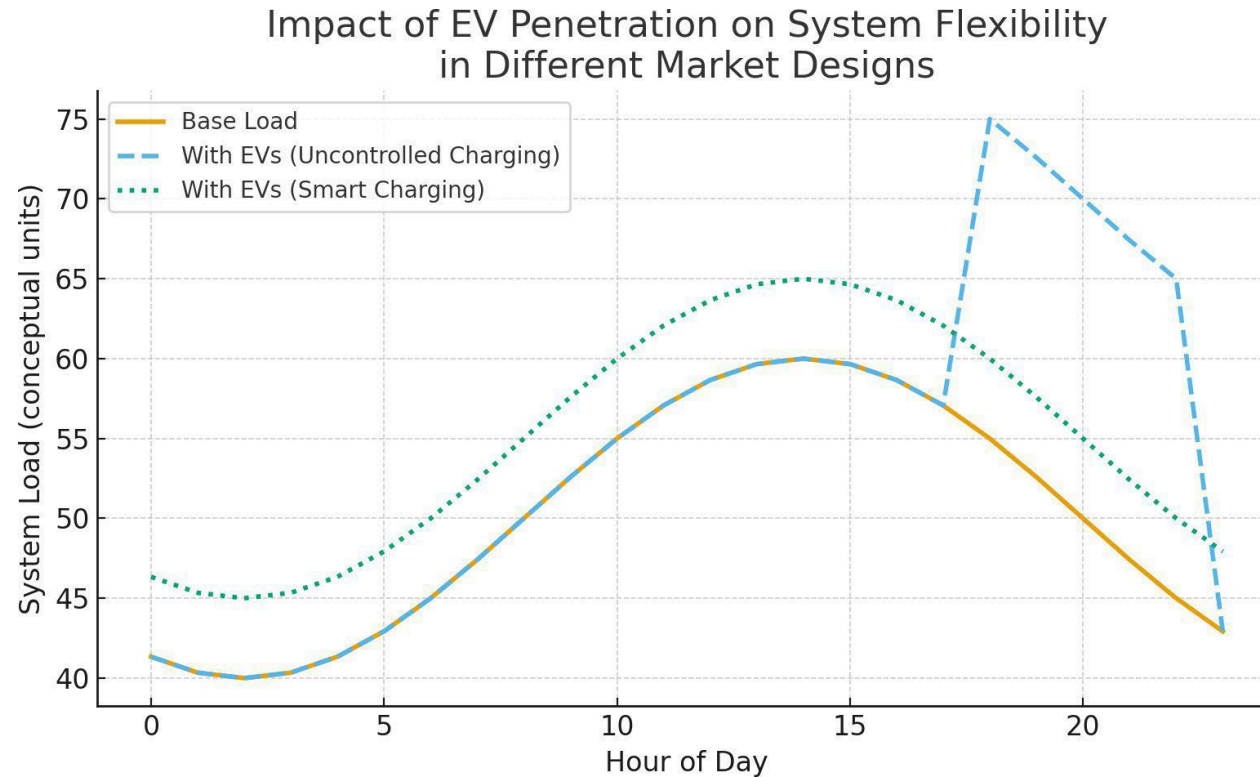

## Keywords:

Electric vehicles (EVs), demand-side flexibility, charging patterns, grid capacity, flexibility potential, market design, vehicle-to-grid (V2G), Nordic/UK/Australia case studies, distribution system impact

## Contact & Information

Contact person: Zeenat Hameed,  
Chresten Træholt, Zoltan Pinter

Mail: [zeeha@dtu.dk](mailto:zeeha@dtu.dk)

Division: Wind and Energy Systems

Master thesis: X

# Exploring wind farm loads trends under control using surrogate models

Reliable prediction of wind turbine loads is essential for reducing costs and enabling advanced wind farm control strategies. Within the EU project TWIN, advanced surrogate models have been developed that capture turbine responses (loads and performance metrics) under different inflow conditions, control modes (yaw and power setpoints), and operational states (production, startup, shutdown, idling). These models are layout-agnostic and control-aware, enabling rapid evaluation of turbine behavior without running computationally expensive simulations.

This thesis will make use of this surrogate model database to investigate how turbine loads vary with ambient conditions and control settings. The focus will be on identifying consistent load trends across different yaw/power combinations and operational states, and on quantifying how wind farm control strategies change the response of individual turbines. Since multiple turbine models are available, the project will also examine whether these trends are consistent across turbines and explore the potential for generalizing load-response patterns from layout-agnostic to turbine-agnostic formulations.

- 1 Pettas V., Cheng P. W.: Surrogate modeling and aeroelastic response of a wind turbine with down-regulation, power boosting and individual blade pitch control capabilities, submitted, *Energies* 17(6) 1284, <https://doi.org/10.3390/en17061284>, 2024
- 2 Frederik, J. A., Simley, E., Brown, K. A., Yalla, G. R., Cheung, L. C., & Fleming, P. A. (2025). Comparison of wind farm control strategies under realistic offshore wind conditions: turbine quantities of interest. *Wind Energy Science*, 10(4), 755-777. <https://doi.org/10.5194/wes-10-755-2025>

Keywords: wind farm loads and control, data analysis

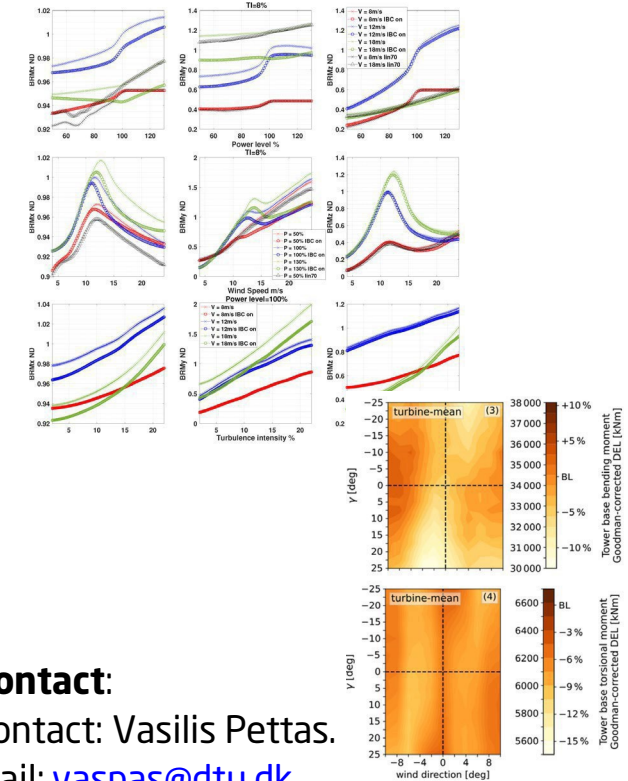

## Contact:

Contact: Vasilis Pettas.

Mail: [vaspas@dtu.dk](mailto:vaspas@dtu.dk)

Division: Wind Energy Systems

Master thesis: X

The TOPFARM [1] Stochastic Gradient Descent optimization driver [2] is increasingly being used in industry. By randomly sampling from the inflow conditions, the driver is able to strategically follow noisy gradients to achieve design solutions that scale favorably with the number of wind turbines. However, many open questions remain surrounding the optimal hyperparameters, learning rate scheduling, and constraint handling scheduling. By fine-tuning the SGD driver the student will have a direct impact on the industry by suggesting a new default behavior of the TOPFARM driver.

Keywords: optimization,  
machine learning, fine-tuning

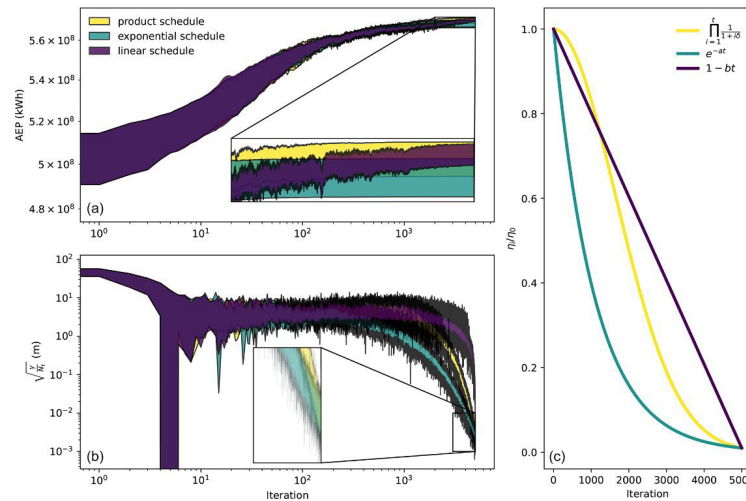

[1] <https://gitlab.windenergy.dtu.dk/TOPFARM/TopFarm2>

[2] Quick, J., Rethore, P. E., Mølgaard Pedersen, M., Rodrigues, R. V., & Friis-Møller, M. (2023). Stochastic gradient descent for wind farm optimization. *Wind Energy Science*, 8(8), 1235-1250.

## Contact:

Contact: Julian

Mail: [juqu@dtu.dk](mailto:juqu@dtu.dk)

Division: Wind Energy Systems

Master thesis: X

The work would analyze how the uptake of battery energy storage systems (BESS) differs in the Nordics, UK, and Australia under current market designs. The modelling could compare how revenues from energy arbitrage and ancillary services stack up in each region, highlighting the policy and regulatory drivers behind storage business cases.

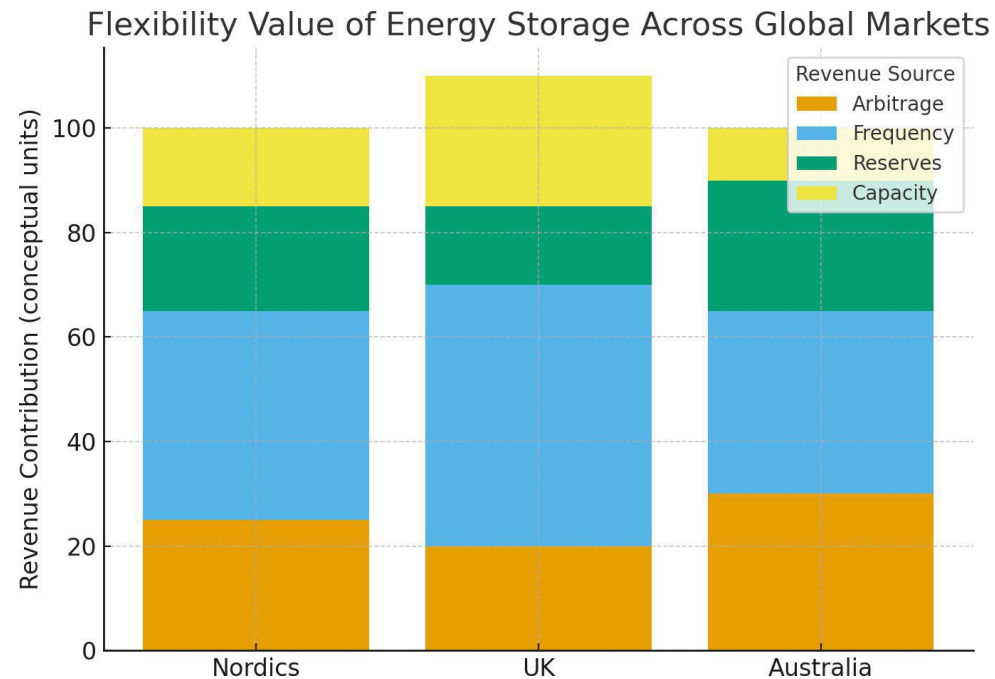

## Keywords:

Battery energy storage systems (BESS), energy arbitrage, ancillary services, storage revenues, flexibility modelling, Nordic/UK/Australia comparison, energy market design, renewable integration, techno-economic analysis

## Contact & Information

Contact person: Zeenat Hameed, Chresten Træholt, Zoltan Pinter

Mail: [zeeha@dtu.dk](mailto:zeeha@dtu.dk)

Division: Wind and Energy Systems

Master thesis: X

We have an increasing number of appliances in our homes, which consume electrical power. Introducing PV systems to these houses makes it possible to locally use the energy. This thesis project aims at designing Energy Management Systems, including a sizing a battery system, which help use energy in the most profitable ways. Potentially, the topic of energy communities is also discussed.

Thesis goals:

- Designing simulation of the loads and generators of the system.
- Discussing data availability and practical limitations of these systems.
- Investigating the problem from the grid perspective, considering the power quality and capacity limitations.
- Designing an optimal system with respect to self-sufficiency and savings on electricity prices.



## Keywords:

Energy management

Heat pump

Home appliances

Battery systems

## Contact & Information

Contact person: Zoltan Pinter, Zeenat Hameed, Chresten Træholt

Mail: [pinzo@dtu.dk](mailto:pinzo@dtu.dk)

Division: Wind and Energy Systems

Master thesis: X



Airborne Wind Energy (AWE) is a technology that utilizes autonomous tethered aircraft to extract energy from the wind. It is important to accurately predict the energy production and the loads carried by this technology. We are happy to host students interested in the high-fidelity modelling of different aspects of AWE. Note, you only need to focus on one discipline, second :

- Aerodynamics
- Structural dynamics
- Control

We already have existing models. So projects can use these tools to perform detailed studies on design innovations, loads, energy production. Or, you can choose to develop your own models. Project details created in discussion with Michael McWilliam ([mimc@dtu.dk](mailto:mimc@dtu.dk)).

## Keywords

- Airborne Wind Energy
- Vortex Aerodynamic Models
- Control Theory
- Structural Dynamics
- Cable Dynamics
- Unsteady Flows
- Programming (python, matlab and/or C++)

## Contact & Information

Contact person: Michael K. McWilliam

Mail: [mimc@dtu.dk](mailto:mimc@dtu.dk)

Division: Wind Energy Systems

Master thesis: X

Bachelor project: X

Can be both: X

Models to synthesize turbulence (for loads & standards) assume Gaussian fluctuations. The non-Gaussian aspect may affect loads, and/or signify particular meteorological phenomena or flow regimes.

- What is the scale-dependence of non-Gaussianity observed at hub-height?
  - How non-normal, how often?
  - Change at different sites
  - Change with height
  - Relation to
    - spectral peak scale
    - coherence
    - anisotropy

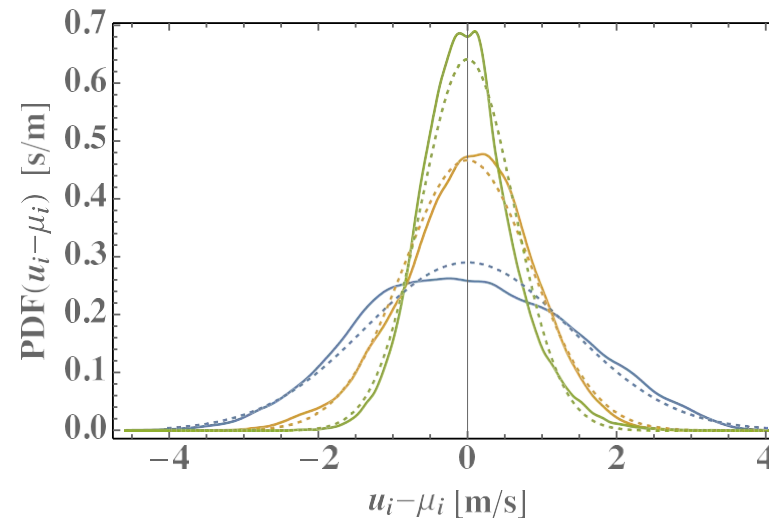

## Keywords

- spectra, statistics
- turbulent velocity fields
- observational data
- uncertainty
- loads

## Contact & Information

Contact person: Mark Kelly

Mail: [MKEL@dtu.dk](mailto:MKEL@dtu.dk)

Division: Wind and Energy Systems

Master thesis project: X

# How supply chain costs from turbine upsizing could impact LCOE

Short description of the thesis/project idea (include an illustration if relevant)

The EU established the Net Zero Industry Act in 2024 to strengthen energy resiliency, speed clean energy deployment, and to create jobs and economic opportunities. Achieving these objectives will require expanding the EU manufacturing base, likely requiring a significant investment in manufacturing facilities, ports, vessels, and other supply chain assets. These investments need to be amortized over the lifetime of the asset to justify the upfront cost. Rapid technology evolution, such as from the turbine 'arms race', creates a risk of supply chain investments becoming obsolete before being fully depreciated, resulting in stranded assets, higher investment risk, and ultimately delays or failures in deployment.

This project will develop a simple economic model for one or more key offshore wind supply chain assets and will use the model to explore the impacts of technology evolution on infrastructure investment. The model should be capable of evaluating parameters such as prevailing labor rates, investment costs, policy / tax conditions, and net present value / IRR. The project will then use the model to explore how different industrialization and technology evolution scenarios could impact the LCOE of different wind projects. These outcomes can be used to help inform improved impact assessment modeling as well as industry / government discussions about the tradeoffs of turbine upsizing and associated policy choices.

## Keywords

Supply chain costs  
Turbine upsizing  
Economic modeling  
Policy analysis  
Model development  
Impact assessment

## Contact & Information

Contact person: Matt Shields

Mail: [mcsh@dtu.dk](mailto:mcsh@dtu.dk)

Division: Wind and Energy  
Systems

Master thesis: X

# Impact of electrolyzer degradation on the operation and design of a hybrid power plant with Power-to-X

The project aims to design and operate a hybrid power plant (HPP) with Power-to-X with an objective to maximize profitability considering the impact of degradation on the operation and profitability of plant. The students are expected to apply mathematical and/or heuristic optimization methods for the sizing algorithm and modeling electrolyzer degradation.

The student is expected to perform the following tasks:

- Perform review of the state of the art
- Familiarization with the tool [HyDesign](#)
- Mathematical modelling of an HPP operation
- Implementation and case studies based on realistic cases

## Keywords

Optimization, mathematical modelling, Hybrid power plants, energy storage technologies

## Contact & Information

Contact person: Megha Gupta

Mail: [gupta@dtu.dk](mailto:gupta@dtu.dk)

Division: Wind Energy Systems

Master thesis: X

The performance of wind power plants are highly dependent on the layout and the wake loss present in the farm. Gradient based optimization is a powerful way to optimize the layout but could be prone to local minima and one strategy to overcome this could be to investigate several initial layouts. The DTU tool for wind farm optimization Topfarm contains a fast greedy heuristic algorithm for generating initial layouts; Smart Start, but other methods exists. Your task will be to implement alternative fast performing algorithms for this purpose and suggest an optimal strategi between generating initial layouts and subsequent gradient based optimization with respect to optimal power and computational performance.



Photo by: Bel Air Aviation Denmark - Helicopter Services

## Keywords

- Layout Optimization of Wind Farms
- Greedy Heuristic
- Gradient Based Optimization
- Sequential Optimization

## Contact & Information

Contact person: Mikkel Friis-Møller,  
Pierre-Elouan Rétoré

Mail: [mikf@dtu.dk](mailto:mikf@dtu.dk)

Division: Wind and Energy Systems

Master thesis: X

Bachelor project: X

Can be both: X

The energy management of wastewater Treatment Plants (WWTPs) must go through several updates, since Denmark committed to decarbonize them by 2030. While they offer flexibility in their operation, some constraints of balancing ammonia and nitrate levels needs to be enforced by proper scheduling of aerator rotors. Models for these will be provided at the beginning of the thesis. A hybrid system will be considered as a combination of WWTP, a battery system and a PV system. We investigate a realized scenario on the island of Bornholm, so sizing is not necessary. The expected outcomes of the master thesis:

- A WWTP model integrated from the energy management perspective, in Simulink.
- Designing a hybrid system in Simulink, or Simscape.
- Designing optimal operation, keeping the constraints of the WWTP, as well as optimizing for self-sufficiency, self-consumption, energy arbitrage and flexibility services.

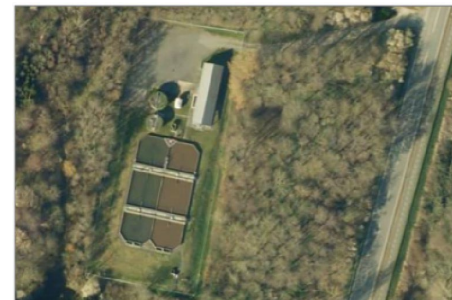

Figure 7 The investigated WWTP in Svaneke

## Keywords:

Flexibility services  
Energy Management Systems  
Wastewater Treatment Plants

## Prerequisites

Flexibility services - concepts  
SimScape or similar  
Optimization concepts

## Contact & Information

Contact person: Zoltan Pinter, Zeenat Hameed, Chresten Træholt  
Mail: [pinzo@dtu.dk](mailto:pinzo@dtu.dk)  
Division: Wind and Energy Systems  
Master thesis: X

# Life Cycle Sustainability Module for Offshore Wind Impact Assessment

## Summary:

With the increasing importance of non-price criteria in offshore wind energy auctions, sustainability indicators require careful evaluation in addition to conventional economic impact assessment. This MSc thesis will investigate how offshore wind rotor scaling affects lifecycle global warming potential (GWP) and other sustainability indicators by developing and integrating an LCA module within an offshore wind farm impact assessment tool. This will allow evaluation of the benefits/tradeoffs of wind turbine scale from both economic and sustainability perspectives.

## Key objectives:

- Identification of appropriate sustainability indicators for inclusion in the LCA module (GWP, Energy payback period, etc.)
- Design of LCA module, with scaling methodology for life cycle inventory parameters (material masses, installation, O&M etc.)
- Implementation within impact assessment module to evaluate economic and sustainability indicators

**Keywords:** Wind energy, sustainability, LCA

## Contact & Information

Contact person: Paul Kerr,  
Moritz Johann Gräfe, Anastasia Ioannou  
Mail: [pauke@dtu.dk](mailto:pauke@dtu.dk),  
Division: Wind and energy systems  
Master thesis: X

The focus here would be on how market design (nodal pricing in Nordics vs zonal in UK vs Australian region-based pricing) influences the valuation of flexibility resources like BESS and EVs. The modelling would assess whether locational pricing better incentivizes efficient deployment and compare outcomes across these three market structures.

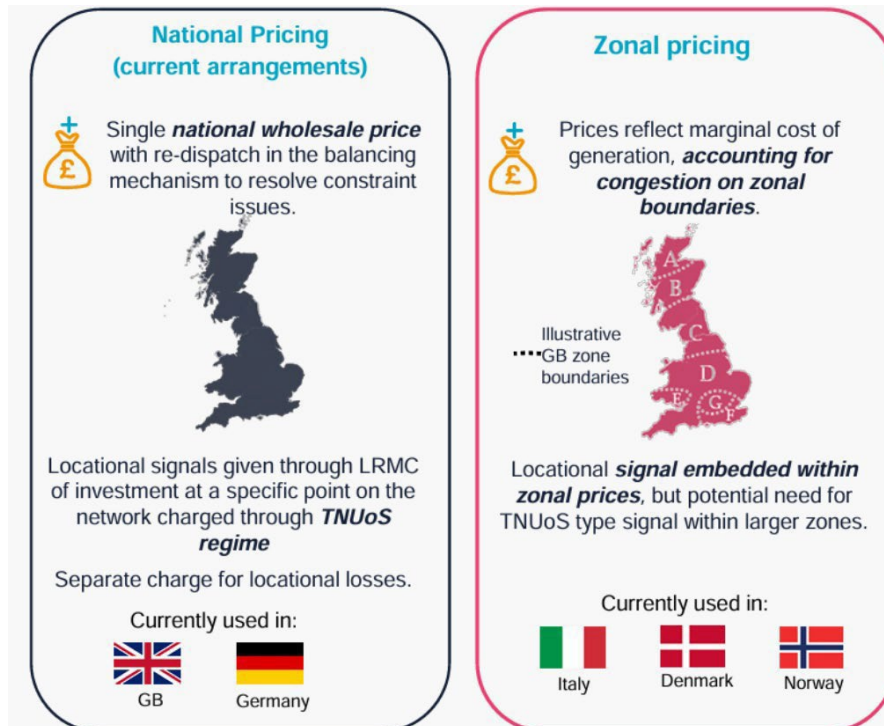

## Keywords:

Locational marginal pricing (LMP), zonal pricing, nodal markets, renewable integration, storage siting, congestion management, flexibility valuation, UK/Nordic/Australia comparison, market design analysis

## Contact & Information

Contact person: Zeenat Hameed, Chresten Træholt, Zoltan Pinter

Mail: [zeeha@dtu.dk](mailto:zeeha@dtu.dk)

Division: Wind and Energy Systems  
Master thesis: X

# Microscale wind data to improve modelling of wind in large-scale energy system studies

Weather data plays a crucial role in energy planning studies. It is thus crucial to model wind generation with as high accuracy as possible. Existing work shows that microscale data, such as Global Wind Atlas (GWA), can increase the accuracy of reanalysis data sets. However, the applied methods are often highly simplified.

This project studies more detailed methods to apply microscale data in large-scale energy system modelling.

## Student tasks:

- Comparison of the existing methods to most accurately model large-scale wind generation in Europe
- Comparison and validation of GWA2, GWA3 and GWA4
- Creation and comparison of new methods, including non-linear ones
- Validation of the final model using measured data from 10+ countries

## Contact & Information

Matti Koivisto:

Mail: [mkoi@dtu.dk](mailto:mkoi@dtu.dk)

Division: Wind Energy Systems

Master thesis: X

## Requirements:

- Basic Python programming
- Basic statistics/data analysis

## Keywords:

- Weather variability
- Microscale
- Wind generation
- Reanalysis
- Energy system studies

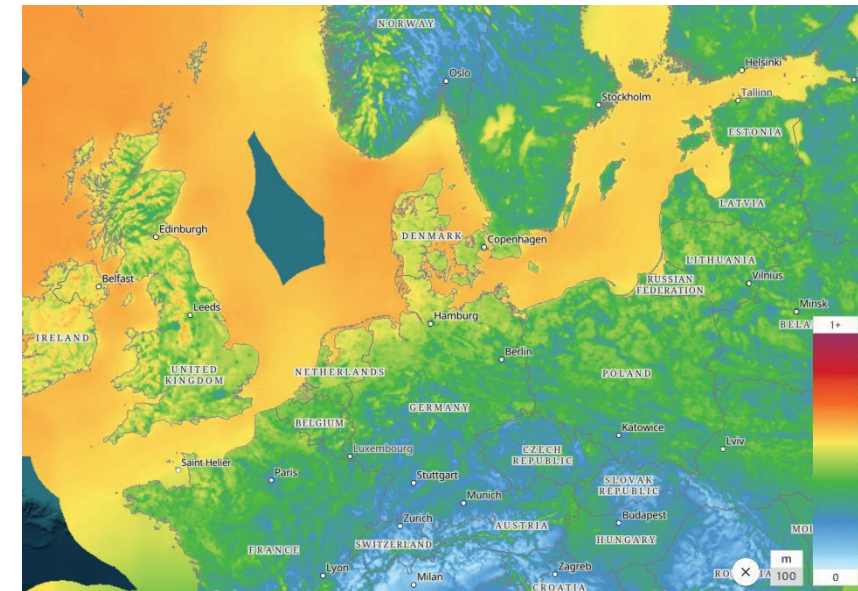

Source: Global Wind Atlas (<https://globalwindatlas.info/en/>)

# Modelling steady state motion of floating offshore wind turbine with TLP foundation

Tension Leg Platform (TLP) is a lightweight floater for floating offshore wind turbines (FOWTs). The TLP design uses tensioned mooring lines fixed into the seabed in order to achieve stability. When multiple FOWTs constitute a floating offshore wind farm (FOWF), their motions under impact of wind, wave and current may have non-negligible effects on the wake flow and power production of the wind farm. This project aims to develop a simple model to simulate the steady state motion of a FOWT with TLP under different met-ocean conditions, by modelling the tensional forces in the mooring lines as function of the platform movements and solving the force and moment balance equations. This model will also be couple with PyWake to assess the influence of these motions on the wind farm

## energy production Contact & Information

Contact person: Ju Feng ([jufen@dtu.dk](mailto:jufen@dtu.dk))  
Division/Company: Wind Energy Systems  
Master thesis: X

**Keywords:** floating offshore wind turbine, TLP, steady state movement

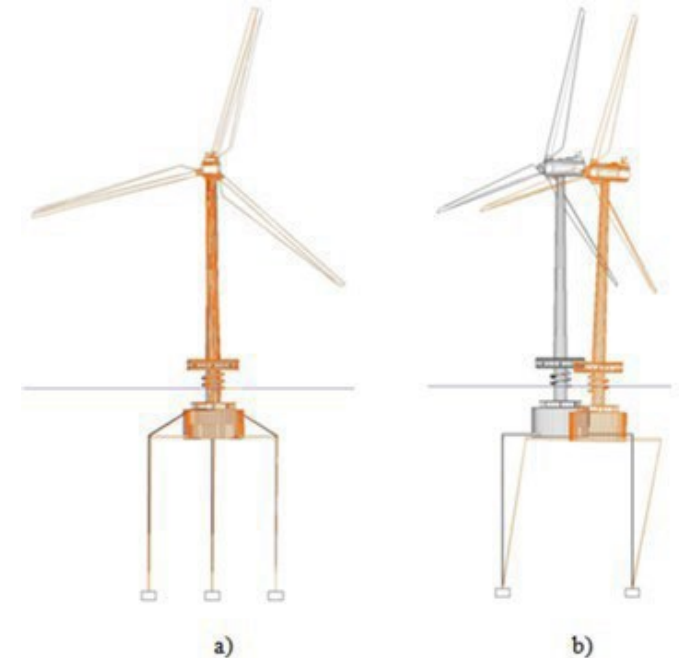

Note: this project is related to the ongoing EU project INF4INiTY (<https://inf4inity.com/>)

# Modelling wind-price boundary conditions for wind farm project evaluation

Wind farm value is driven not only by average wind and average price but by their joint distributions, when the wind blows relative to when prices are high. Boundary conditions in both climate and markets are evolving, so historical correlations between wind and price may shift across countries, bidding zones, and seasons. This thesis will quantify how wind-price co-dependence varies over time and geography and develop realistic generators of joint wind and price time series that can reproduce seasonality, regimes, and tail events, and use these scenarios to stress-test the economics of a reference wind farm. The end goal is a transparent methodology and software tool that helps developers and traders understand NPV and risk under changing boundary conditions, and to identify robust bidding and contracting choices.

Keywords: data analysis, time series generation, economic evaluation

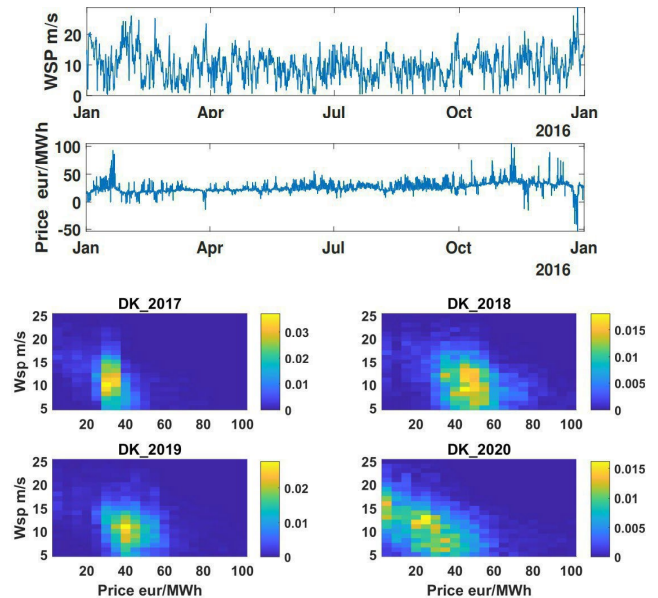

[1] Pircalabu, A., T. Hvolby, J. Jung, and E. Høgg. 2017. "Joint Price and Volumetric Risk in Wind Power Trading: A Copula Approach." *Energy Economics* 62 (February): 139-54. <https://doi.org/10.1016/j.eneco.2016.11.023>.

Contact: Vasilis Pettas, Moritz Gräfe

Mail: [vaspas@dtu.dk](mailto:vaspas@dtu.dk),  
[mograf@dtu.dk](mailto:mograf@dtu.dk)

Division: Wind Energy Systems

Master thesis: X

# Modulation of small-scale turbulence by large-scale atmospheric structures

To what extent (and how) do coherent structures modulate turbulence at smaller scales than these structures?

- Study effect of “large” (>1km) coherent structures on small-scale velocity
  - turbulence magnitudes
  - different components and directional aspects
- The problem here is two-fold:
  - large-scale “turbulence” affects wind fields, and can impact wind farm power production;
  - small-scale turbulence (wind turbine rotor size and smaller) is crucial for estimating wind turbine loads and turbine wake recovery.
- DTU has a rich dataset from multiple lidars and meteorological masts that can be used in this study.

## Keywords

- Coherent Structures
- Wind Farm Flow
- PyWake

## Requires :

- knowledge of python
- knowledge of atmospheric turbulence
- knowledge \ wish to learn signal processing with wind data

## Contact & Information

Contact person: Leonardo Alcayaga

Mail: [LALC@dtu.dk](mailto:LALC@dtu.dk)

(+Mark Kelly, [MKEL@dtu.dk](mailto:MKEL@dtu.dk))

Division: Wind and Energy Systems

Master thesis project: X

# Optimization of maintenance routing and scheduling for offshore wind farms

Operation and maintenance (O&M) costs constitute a substantial part of cost for offshore wind farms. Maintenance routing and scheduling aims to find the best routes for the Crew Transfer Vessels (CTVs) to maintain the turbines. Decisions, like when to drop and pick-up the technicians at the turbines that need maintenance in which order, need to be made considering the requirements of maintenance tasks, capacities of CTVs and technicians and locations of turbines. This project aims to review the literature, formulate the problem, and write the code to simulate the process and optimize the routing, mainly based on selected models presented in some of the published papers.

**Keywords:** Offshore wind farm, O&M, maintenance routing and scheduling, optimization

## Contact & Information

Contact person: Ju Feng

Mail: [jufen@dtu.dk](mailto:jufen@dtu.dk)

Division: Wind and Energy Systems

Master thesis: X

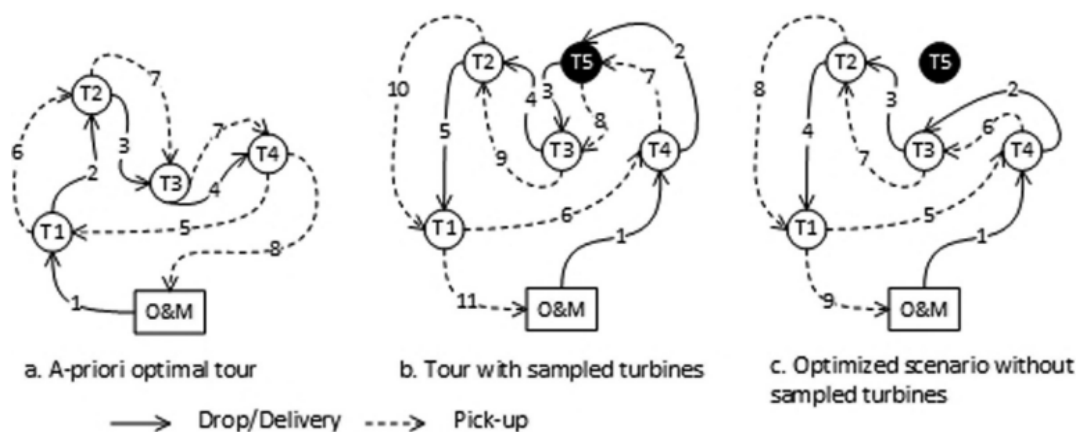

[Ref] Chandra Ade Irawan, et al. "Simulation-based optimisation for stochastic maintenance routing in an offshore wind farm", *European Journal of Operational Research*, 289, (2021), 912-926

# Robust optimisation of offshore wind farm layouts under uncertain conditions (with RWE)

## Context:

Offshore wind projects face shifting realities: wind climate varies over time, and “developable area” can change as bathymetry and soil surveys refine constraints. This thesis explores layout designs that **stay good when conditions move**, using robust optimisation so turbine positions deliver strong performance across different wind and area scenarios, not just a single best-guess case.

## Research objectives:

- Review robust optimisation strategies for wind-farm layouts under uncertainty, including **stochastic gradient descent (SGD)** and related methods; identify pros/cons for this use-case.
- Formulate uncertainty models (e.g., wind-rose variability; evolving developable area polygons) and define robustness metrics (e.g., expected, worst-case, or regret-based performance).
- Implement the chosen robust strategy in **Python** using **PyWake** (open-source wake modelling library) and **TopFarm** (layout optimisation framework), with reproducible experiments.
- Generate optimised layouts under multiple uncertainty sets and benchmark against non-robust baselines.
- Synthesize findings into guidance on when and how to use the method for industrial layout studies.

## Competences you will gain:

- Robust optimisation under uncertainty for complex energy systems; hands-on with **SGD** and scenario-based evaluation.
- Advanced **Python scientific programming** (NumPy/SciPy/Pandas), experiment design, profiling, and reproducibility.
- Proficiency with **PyWake** (wake/flow modelling) and **TopFarm** (constraint handling, cost functions, optimisers).
- Uncertainty modelling (wind-climate statistics, geometry/area uncertainty) and robustness metrics.
- Critical benchmarking and result communication for industry audiences (figures, reports, and clear recommendations).
- Collaboration with an industrial partner (**RWE**) on a problem of immediate practical impact.

## Collaboration & supervision:

In collaboration with **RWE**; thesis supervision by **Pierre-Elouan Réthoré**, and **Julian Quick (DTU Wind Energy - SYS)**.

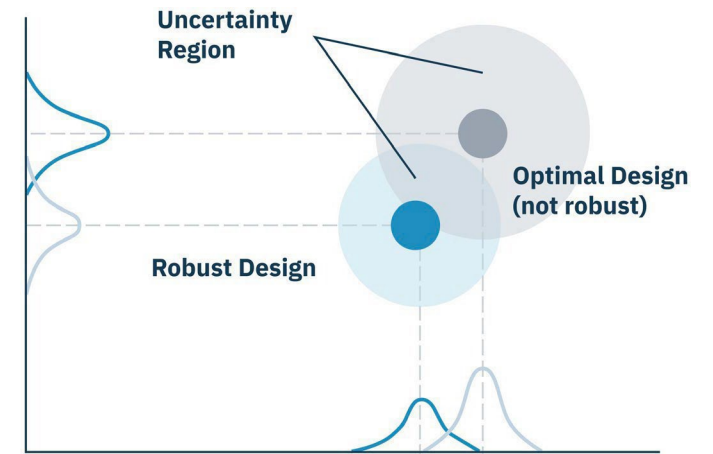

## RWE

## Contact & Information

Contact person: Pierre-Elouan Réthoré Mail:

[pire@dtu.dk](mailto:pire@dtu.dk)

Division: Wind and Energy Systems

Master thesis: X

# Satellite remote sensing on ocean winds

BOTH

Satellite remote sensing of ocean surface wind study is focused on high-resolution Synthetic Aperture Radar (SAR) data. The radar sense the ocean winds through clouds and rain, day and night. DTU Wind produces near-real-time SAR ocean wind maps.

- The first question in the study: How does ocean wind maps from DTU Wind processing method compare to ocean wind maps from COPERNICUS, the EU monitoring system based on data from the European Space Agency.
- The second question in the study: How can we quantify the effect of offshore wind farms wakes using satellite SAR.

Two SAR wind examples:

Lee waves near the UK North Sea

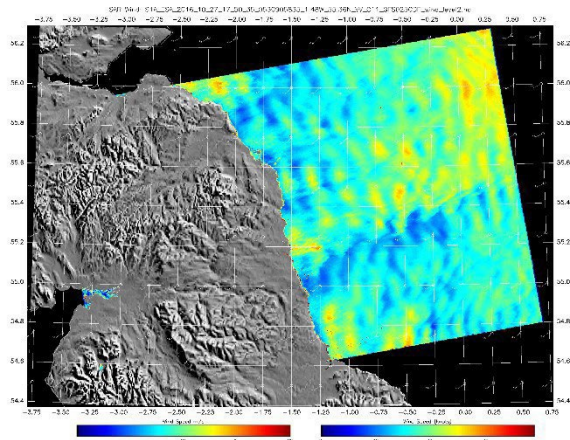

DTU Technical University of Denmark. Processed at DTU Wind Energy, ACTU Oct 20 11:12:49 UTC

Wind farm wakes in the German Bight

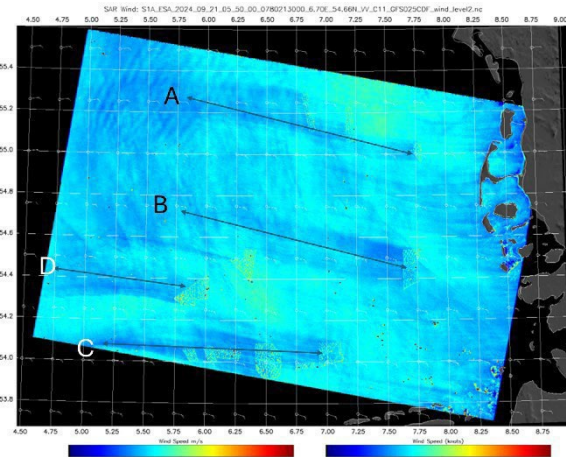

DTU Technical University of Denmark. Processed at DTU Wind Energy, 2024 Sep 21 11:07:42 UTC

## Keywords

Synthetic Aperture Radar  
 European Space Agency  
 Satellite remote sensing  
 Offshore wind mapping  
 Wind energy  
 Wind farm wakes

## Contact & Information

Contact person: Charlotte Hasager and Krystallia Dimitriadou  
 Mail: [cbha@dtu.dk](mailto:cbha@dtu.dk) & [krstd@dtu.dk](mailto:krstd@dtu.dk)

Institute: Wind and Energy Systems  
 Master thesis: X  
 Bachelor project: X  
 Can be both: X

The **Dynamic Wake Meandering (DWM) model** is widely recognized as the workhorse for load assessment of modern wind turbines. Yet, under certain conditions—particularly at **low inflow turbulence intensity (TI)**—the DWM model has been shown to **significantly underpredict tower loads** on downstream turbines when compared to high-fidelity **Large Eddy Simulations (LES)** [1]. This discrepancy raises an important research question: *why does the model fail under these conditions?* Several potential drivers need to be disentangled, including **wake asymmetry, the dynamics of wake meandering, and the structure and energy distribution of turbulence**. By systematically addressing these aspects, the project aims to identify the dominant mechanisms behind the mismatch, ultimately guiding improvements to the DWM framework where they matter most.

For this project, LES and DWM reference datasets are available for a **waked IEA 22 MW reference turbine** operating below rated wind speed, including cases with **veer and yaw** in **neutral atmospheric conditions**. The MSc project would unfold in several stages:

- **In-depth comparison of the flow fields**, focusing on the wake evolution and turbulence characteristics.
- **Targeted manipulations of the flow fields** to isolate the influence of individual factors such as asymmetry, meandering, or turbulence content.
- **Load simulations in HAWC2** using these adapted flow fields to assess their impact on structural responses.
- **Comparison of load predictions** across different scenarios to reveal which physical mechanisms are most critical for accurate tower load estimation.

Through this study, the student would gain hands-on expertise with **DWM modeling, HAWC2 load simulations, and advanced flow-field analysis** using **Python**. The project sits at an interesting intersection between fundamental and applied research giving the student an opportunity to contribute to a topic both relevant for industry and academia.

[1] [doi.org/10.1088/1742-6596/2505/1/012054](https://doi.org/10.1088/1742-6596/2505/1/012054)

**Keywords:** DWM, loads

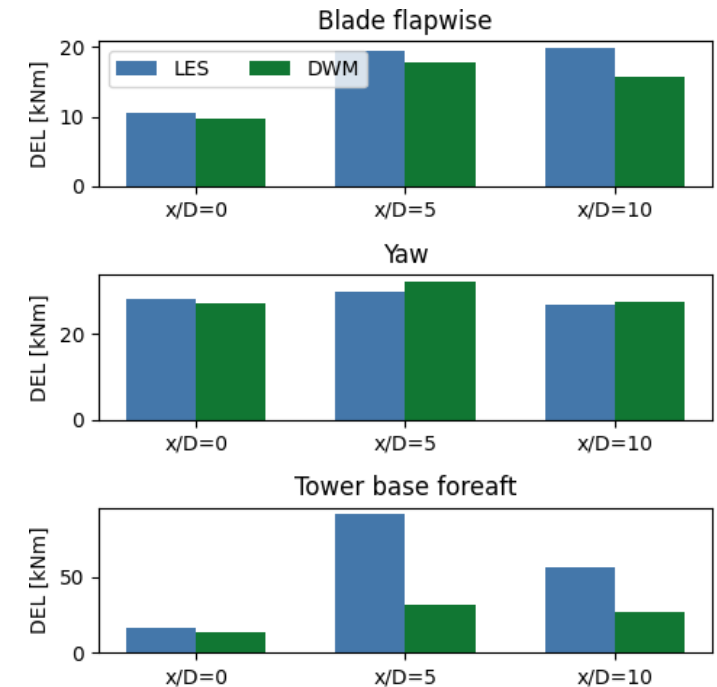

**Contact & Information** Contact

person: Julia Steiner Mail:

[julstei@dtu.dk](mailto:julstei@dtu.dk)

Division: Wind and Energy Systems

Master thesis: X

# Simulation of the wake of a turbine in WRF-LES: a comparison with 3D lidar measurements

## Short description of the project

Detailed wind turbine wake observations and simulations to advance the understanding of the interaction between the atmospheric turbulent flow and a turbine. The **learning objectives** of this project is to **analyse**: 1. data from a simulation of wake of a small wind turbine using the large-eddy simulation (LES) capability of the Weather Research and Forecasting (WRF) model and 2. field observations from scanning wind lidars to **assess** the capability of high-fidelity models to accurately reproduce the turbulence characteristics of wake flows.

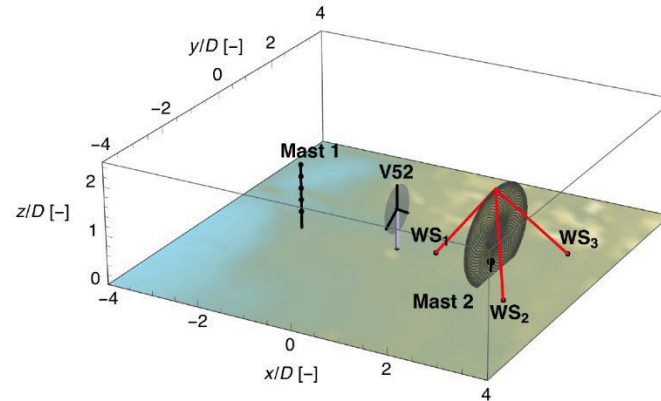

Figure 1. A sketch of the 3D lidar measurement campaign. Normalized distances from the turbine position with the  $x$ -axis along the inflow mast (Mast 1) and turbine (V52) line

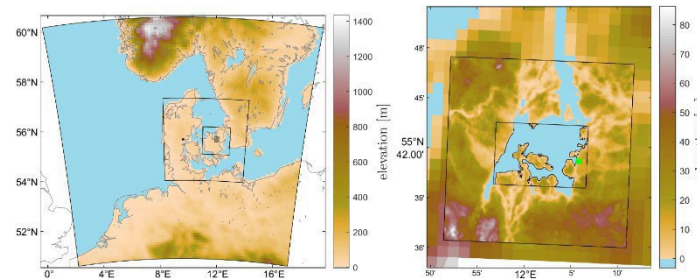

Figure 3. (left) Nested domain configuration (domains in black lines) used for the WRF model simulations. (right) The two innermost LES domains covering the Riso test site with the V52 turbine position in green

## Keywords:

- Wind turbine wake
- Scanning Doppler lidar
- Field Campaign
- Advanced turbulence-resolving (WRF-LES)
- Wind modelling data

## Contact & Information

Contact person: Alfredo Peña /

Nikolas Angelou

Mail: [aldi@dtu.dk](mailto:aldi@dtu.dk) / [nang@dtu.dk](mailto:nang@dtu.dk)

Division: Wind and Energy System

Master thesis: X

Bachelor project: X

Can be both: X

# Sizing of hybrid power plants using surrogate-based high fidelity EMS under uncertainties

The project aims to design a renewable hybrid power plant (HPP) with multiple technologies co-located behind a single point of grid connection (wind, solar, battery, hydrogen, etc.). The design objective could be maximizing profitability, minimizing LCoE, minimizing carbon footprints etc. The students are expected to build a surrogate model for a high fidelity EMS and use it for sizing

The student is expected to perform the following tasks:

- Perform review of the state of the art of surrogated based methodologies
- Familiarization with the tool [HyDesign](#) and [HyDesign.HiFiEMS](#)
- Build the surrogate model of a high fidelity EMS
- Integrate the surrogate EMS in HyDesign and perform analysis

## Keywords:

Optimization, Surrogate model, Uncertainty, Hybrid power plants

## Recommended prerequisites:

Optimization methods, Machine learning, python coding

## Contact & Information

Contact person: Rujie Zhu, Kaushik Das

Mail: [ruzhu@dtu.dk](mailto:ruzhu@dtu.dk), [kdas@dtu.dk](mailto:kdas@dtu.dk)

Division: Wind Energy Systems

Master thesis: X

# Sizing optimization of multi-technology hybrid power plants

The project aims to design a renewable hybrid power plant (HPP) with multiple technologies co-located behind a single point of grid connection (wind, solar, battery, hydrogen, etc.). The design objective could be maximizing profitability, minimizing LCoE, minimizing carbon footprints etc. The students are expected to apply mathematical and/or heuristic optimization methods for the sizing optimization.

The student is expected to perform the following tasks:

- Perform review of the state of the art of sizing optimization methodologies
- Familiarization with the tool [HyDesign](#)
- Mathematical modelling of sizing optimization method (heuristic methods)
- Comparing the different methods of sizing.

## Keywords

Optimization, mathematical modelling, Hybrid power plants

## Contact & Information

Contact person: Megha Gupta

Mail: [gupta@dtu.dk](mailto:gupta@dtu.dk)

Division: Wind Energy Systems

Master thesis: X

Some research questions:

- How does the distribution of stability change, over typical wind speeds?
- To what extent can we use a single stability distribution to estimate the long-term effect on the mean profile & distribution of wind speeds?
- How might this affect wind & AEP predictions?

- Involves:
  - Conditional statistics
  - Wind speed dependence of stability distributions
  - Other stability joint behavior
  - Impact on wind profile

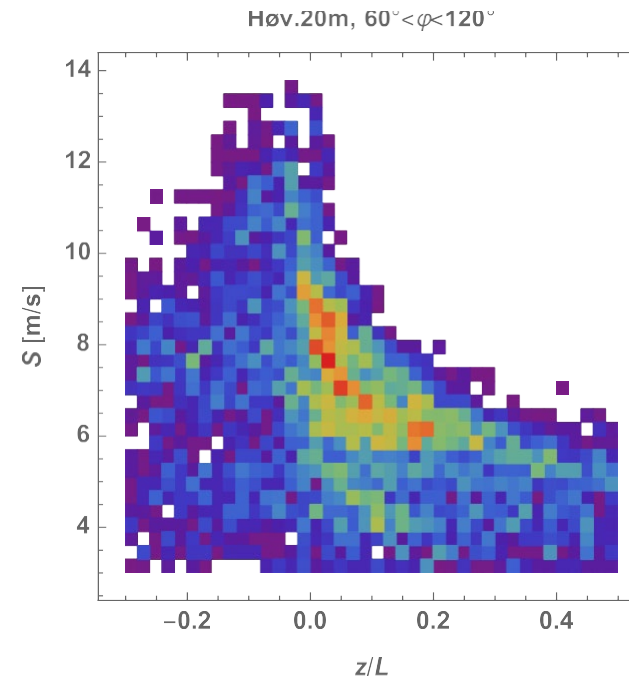

## Keywords

- Wind resource
- Uncertainty quantification (UQ)
- Computational (e.g. Python)
- Stability

## Contact & Information

Contact person: Mark Kelly

Mail: [MKEL@dtu.dk](mailto:MKEL@dtu.dk)

Division: Wind and Energy Systems

Master thesis project: X

Join us in the journey of implementing battery systems for energy arbitrage and flexibility services! These systems can help balance the electrical grid, while facing stochastic or intermittent generations and loads (renewables and EVs) via limited-capacity lines. In this thesis, we investigate the optimal interaction of the battery strings with a variety of services, and optimize for some of the following objectives:

- Service requirements
- Systems robustness and integrity
- Return on investment
- Efficiency
- A robust business case for such systems

The expected perspectives can be sizing, investigation of high-level topologies, power flows, and market entry.

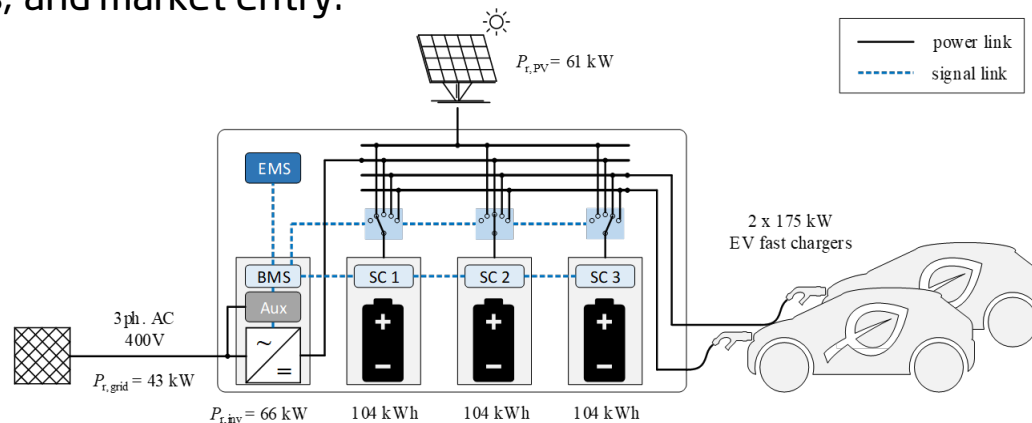

## Keywords:

Flexibility services

Energy Management Systems

## Prerequisites

Flexibility services - concepts

SimScape or similar

Optimisation concepts

## Contact & Information

Contact person: Zoltan Pinter, Zeenat

Hameed, Chresten Træholt

Mail: [pinzo@dtu.dk](mailto:pinzo@dtu.dk)

Division: Wind and Energy Systems

Master thesis: X

# Supply chain risk assessment for future wind energy systems

Short description of the thesis/project idea (include an illustration if relevant)

The EU established the Net Zero Industry Act in 2024 to strengthen energy resiliency, speed clean energy deployment, and to create jobs and economic opportunities. Achieving these objectives will require expanding the EU manufacturing base, however, the ability of the supply chain to meet the needs of future wind energy system designs is not clear. In particular, the push towards larger wind turbines and floating offshore wind presents a challenge for existing manufacturing and logistics capabilities. A better understanding of supply chain risks, and how they could be addressed by targeted policy, investment, or turbine design, could help to achieve the NZIA objectives.

In this project, we will develop a supply chain risk metric that encompasses key factors such as dependency on rare earth elements, availability of existing EU capabilities, geopolitical dependencies, etc. We will apply this metric to a series of onshore and offshore wind farm case studies which include future-looking technologies (ie, 20 MW offshore turbines, recyclable blades, HVDC cables, etc). We will compare the results of the project-level risk assessment of each project design with conventional performance criteria such as LCOE or AEP to explore the tradeoffs between cost minimization and supply chain resiliency. The outcomes of the project can help to frame the discussion with policy makers and the wind industry around technology industrialization and commercialization, energy security, and cost reduction.

## Keywords

Supply chain  
Rare earth elements  
Risk analysis  
Technology assessment  
Model development  
Impact assessment

## Contact & Information

Contact person: Matt Shields  
Mail: [mcs@dtu.dk](mailto:mcs@dtu.dk)  
Division: WindandEnergy  
Systems  
Master thesis: X

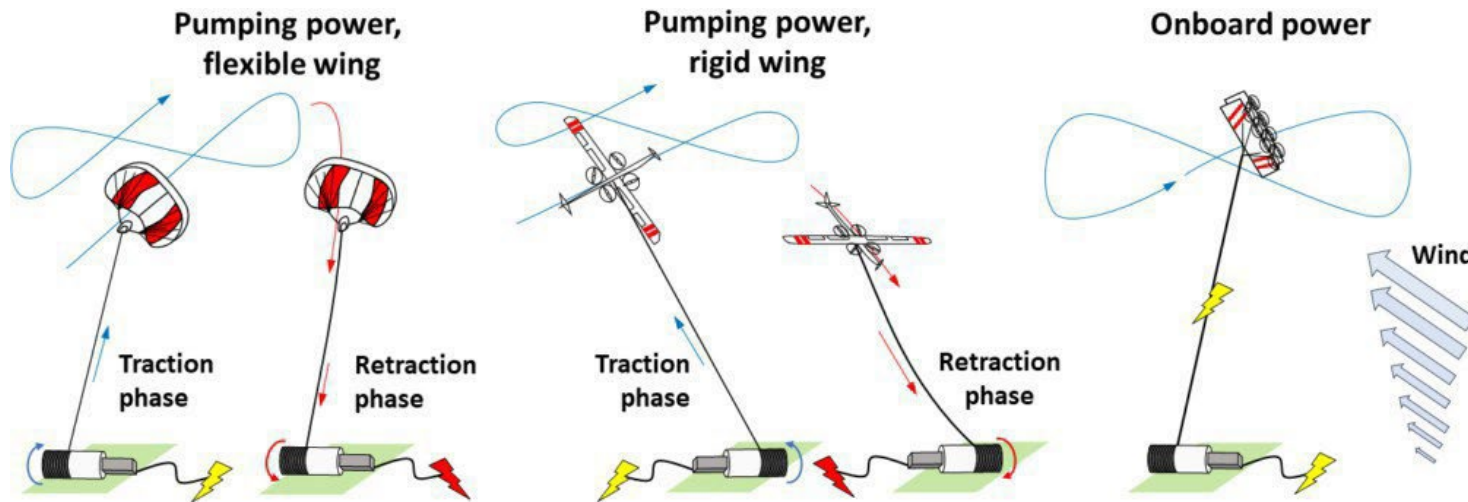

Airborne Wind Energy (AWE) is a technology that utilizes autonomous tethered aircraft to extract energy from the wind. There are several interesting topics under system engineering for

- What is the techno-economic potential of AWE in Europe
    - Cost modelling
    - Wind resource & geography
    - Annual energy production
  - What is the potential for radical AWE concepts? We can discuss the innovation
- System engineering utilizes multiple simple models to understand technology at a system level  
 Project details figured out in discussion, please contact Michael K. McWilliam ([mimc@dtu.dk](mailto:mimc@dtu.dk))

## Keywords

- Airborne Wind Energy
- System Engineering
- Aerodynamics
- Structural Dynamics
- Cost modelling
- Hybrid Power Plants
- Wind resource assessment
- Annual energy production
- Programming (python or matlab)

## Contact & Information

Contact person: Michael K. McWilliam  
 Mail: [mimc@dtu.dk](mailto:mimc@dtu.dk)  
 Division: Wind Energy Systems  
 Master thesis: X  
 Bachelor project: X  
 Can be both: X

# Techno-economic analysis of hybrid power plants with PPA and ancillary service markets participation

The project aims to develop an optimization model for hybrid power plants (HPPs) with both power purchase agreement(PPA) and ancillary service market participation.

The student is expected to perform the following tasks:

- Develop an energy management system model for HPPs participating in ancillary service markets
- Design a PPA for HPPs considering the ancillary service markets participation
- Perform techno-economic analysis

## Keywords:

Optimization, PPA, Ancillary service, Hybrid power plants

## Recommended prerequisites:

Optimization methods, python coding

## Contact & Information

Contact person: Rujie Zhu, Kaushik Das

Mail: [ruzhu@dtu.dk](mailto:ruzhu@dtu.dk), [kdas@dtu.dk](mailto:kdas@dtu.dk)

Division: Wind Energy Systems

Master thesis: X

- How can we characterize the resolution of our terrain maps?  
E.g.:
  - terrain character at smallest scales
  - deviations due to processing
- What resolution of flow model can give improvement, per map input?

Involves:

- Terrain spectra analysis for better microscale modelling
- conditional reduction of resolution requirements

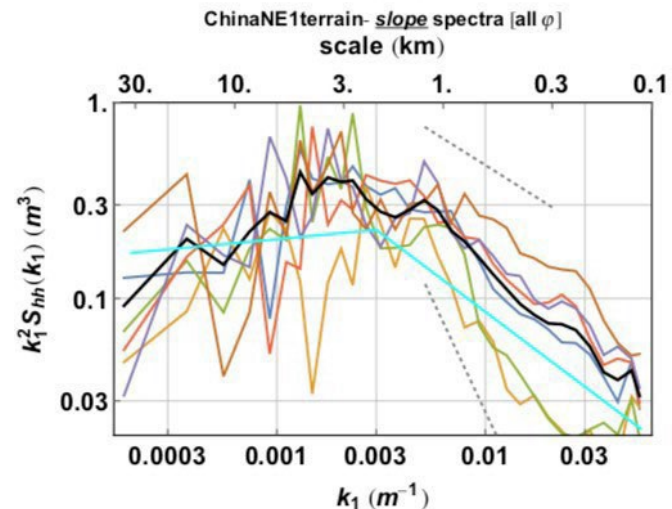

## Keywords

- Microscale modelling
- Spectra & filtering
- Resolution
- Surface description
- Wind resources

## Contact & Information

Contact person: Mark Kelly

Mail: [MKEL@dtu.dk](mailto:MKEL@dtu.dk)

Division: Wind and Energy Systems

Master thesis project: X

Modeling how **non-uniform inflow conditions** affect wind turbine wakes has become increasingly important in modern wind energy research. As turbines grow larger, they become far more sensitive to atmospheric features such as **shear and veer**. At the same time, **wake steering** has emerged as one of the most promising flow-control strategies for improving wind farm performance. Wake steering involves intentionally applying a **yaw offset** to an upstream turbine, thereby deflecting its wake away from downstream machines to reduce losses.

However, the physics of wakes under non-uniform inflow are complex. Observations and **high-fidelity LES simulations** consistently show that the wake of a yawed turbine is no longer axisymmetric with respect to the mean flow. Similarly, **shear and veer in the inflow** also generate **non-axisymmetric wake structures**, further complicating wake behavior. In yawed cases, two **counter-rotating vortices** are shed from the top and bottom of the rotor plane, leading to deformation and roll-up of the wake—effects that are strongly influenced by shear and veer as well. Capturing these dynamics is crucial for accurate prediction and optimization of wind farm performance.

We are setting up MSc thesis projects in this exciting area. Each project can be adapted to the student's interests and background. Possible topics include:

- **Benchmark the internal implementation of the Curled Wake Model** (developed by NREL) against its original publications [1,2] as well as **in-house LES datasets**. The model can also be further adapted so the evaluation becomes quicker.
- **Implementation of a 3D parabolic solver in Python** capable of handling **non-uniform inflow conditions**. An initial prototype could follow the approach of [3], but adapted to **Cartesian coordinates**.

These projects offer the opportunity to combine **theory, modeling, and computation**. Students will gain hands-on experience in **numerical modeling, Python implementation, and comparison against LES reference data**, while contributing to developments in wake modeling.

1 <https://doi.org/10.5194/wes-4-127-2019>

2 <https://doi.org/10.1002/we.2785>

3 <https://doi.org/10.1002/we.2154>

**Keywords:** DWM, wake modeling, veer, shear, yaw

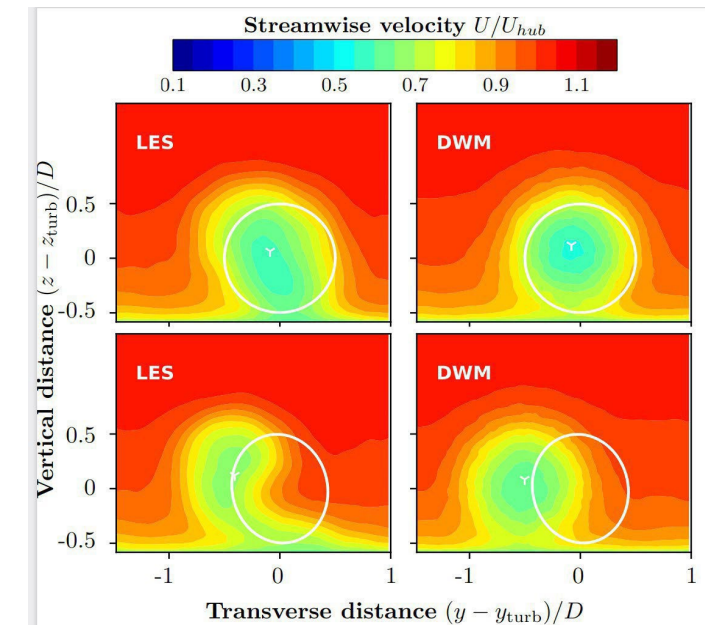

## Contact & Information

Contact person: Julia Steiner

Mail: [julstei@dtu.dk](mailto:julstei@dtu.dk) Division:

Wind and Energy Systems

Master thesis: x

We aim to develop a **fast time-domain simulation tool for wind turbine wakes**—one that can both **capture wake expansion accurately** and **resolve different levels of wake meandering**. Such a tool would have direct applications in areas like **forecasting and optimization**, where both accuracy and speed are critical.

Currently, the **Dynamic Wake Meandering (DWM) model** serves as the go- to mid-fidelity model for simulating time-series wake behavior. It accounts for wake expansion through turbulent mixing and meandering, and while it is far faster than high-fidelity CFD approaches, it still falls short when used in **real- time or optimization frameworks**. The main computational bottleneck lies in the **wake deficit calculation**, most commonly handled using the **Ainslie model**.

This project's first milestone is therefore the creation of a **surrogate model for the Ainslie deficit model**, trained across a range of **thrust coefficients** and **turbulence intensities**. This surrogate would reduce computation time significantly. See the plot for a comparison of computation time as a function of the time step of the simulation for an analytical deficit model (here a PyWake deficit) and the Ainslie model.

Once a robust surrogate is in place, the project would move toward the next challenge: enabling **variable time-step simulations**. This requires embedding part of the **wake expansion due to meandering** directly into the deficit model. Multiple strategies exist for achieving this, offering the student room for exploration and innovation.

The project is **flexible** and can be tailored to match the student's specific interests. Along the way, the student will gain valuable experience with **reduced-order modeling, data-driven methods, and wake dynamics in wind energy**.

**Keywords:** DWM, wake modeling

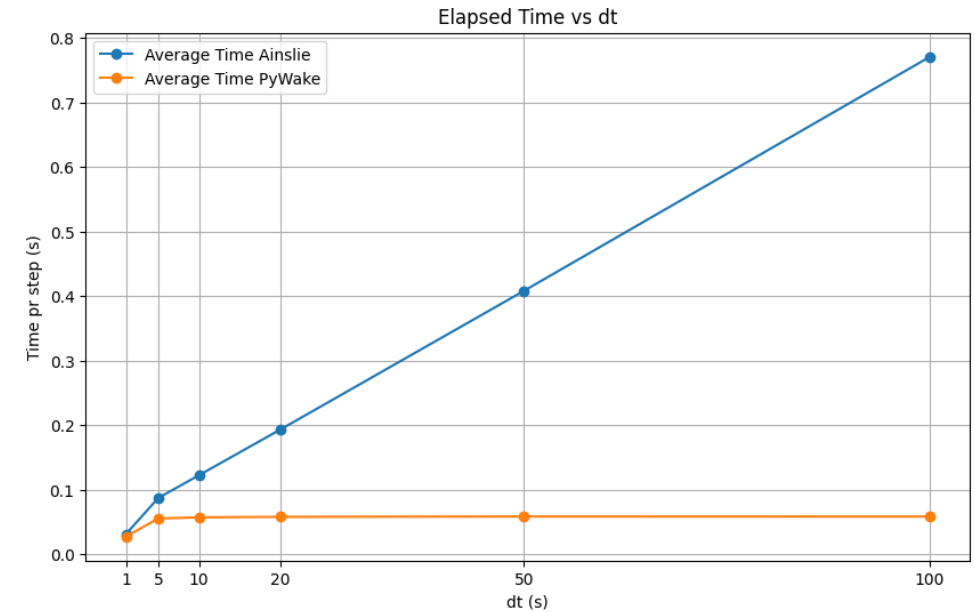

## Contact & Information

Contact person: Julia Steiner

Mail: [julstei@dtu.dk](mailto:julstei@dtu.dk)

Division: Wind and Energy  
Systems

Master thesis: X

# Wake steering wind farm control considering limits of turbine yaw systems

Wind farm control by steering the wakes through yawing wind turbines has become a hot field recently. Studies based on numerical simulations, wind tunnel experiments and field measurements have confirmed its feasibility to increase the power output of wind farm. Several engineering wake model for yawed turbines have also been proposed in the literature. However, most of the existing research is based on steady state simulation and optimization, without considering the limits of turbine yaw systems, such as how fast a turbine can be yawed and what's the related cost. In this project, we will:

- model the turbine yaw systems more realistically;
- consider the control efforts related to cost of yawing activities;
- design and evaluate the optimal wake steering strategy

**Keywords:** wind farm control, wake steering, yaw system, control efforts

## Contact & Information

Contact person: Ju Feng ([jufen@dtu.dk](mailto:jufen@dtu.dk))  
Division/Company: Wind Energy Systems  
Master thesis: X

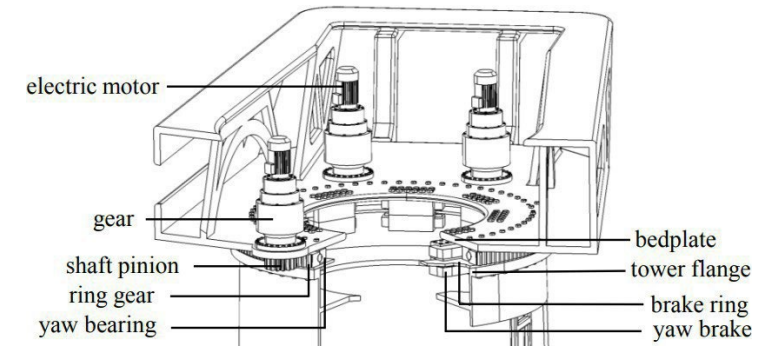
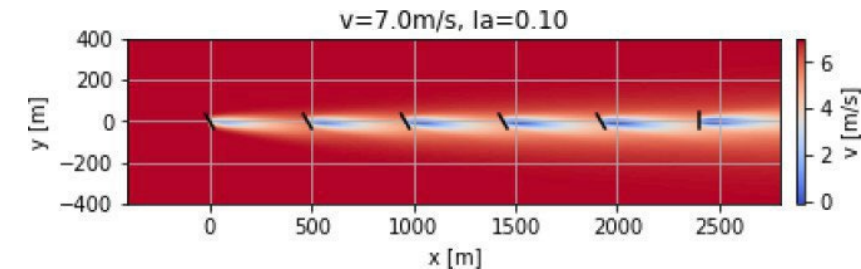

Figure 1. Example of a yaw system.



[Ref] M.G. Kim and P.H. Dalhoff, "Yaw Systems for wind turbines - Overview of concepts, current challenges and design methods", Journal of Physics: Conference Series, (2014), **524**, 012086

# Wake surrogate model for offshore wind farm layout optimization (with RWE)

## Context

Offshore wind build-out in the North Sea is packing farms closer together, making inter-farm “cluster wake” effects a major driver of production and cost. Engineering wake models are fast for layout optimisation but can miss complex flow physics; high-fidelity models are accurate but slow. This thesis develops a machine-learning-based wake **surrogate model** trained on RWE’s internal wake simulations to bring high-fidelity insight into fast optimisation workflows.

## Research objectives

- Map the state of the art on wake surrogate modelling and related surrogate strategies.
- Define training/validation cases, performance metrics, and scenarios representative of dense offshore clusters.
- Generate a high-quality dataset from RWE’s internal wake model for training and testing.
- Build and validate surrogate(s) with machine learning and AI, quantify accuracy-speed trade-offs, and stress-test generalisation.
- Integrate the surrogate into **PyWake** for flow/effects evaluation and **TopFarm** for layout optimisation; benchmark against standard engineering models on runtime and farm-level KPIs.
- Conclude on applicability/limits for cluster-aware layout optimisation and outline next steps for industrial deployment.

## What you’ll master

- **Python scientific programming** at scale (data pipelines, profiling, testing) with **PyWake** and **TopFarm**.
- **Machine learning for surrogates:** model selection, hyper-parameter tuning, cross-validation, error analysis, and uncertainty awareness.
- **Wind-farm layout optimisation:** setting up constraints/objectives, running comparative studies, and interpreting farm-level KPIs.
- **Experiment design & reproducibility:** version control, structured datasets, clear documentation.
- **Industry collaboration & communication:** working with RWE engineers and reporting results to mixed audiences.

## Supervision & collaboration

Industry partner: **RWE**. Academic supervisor: **Pierre-Elouan Réthoré (DTU Wind Energy - SYS)**.

Primary tools: **Python, PyWake, TopFarm**.

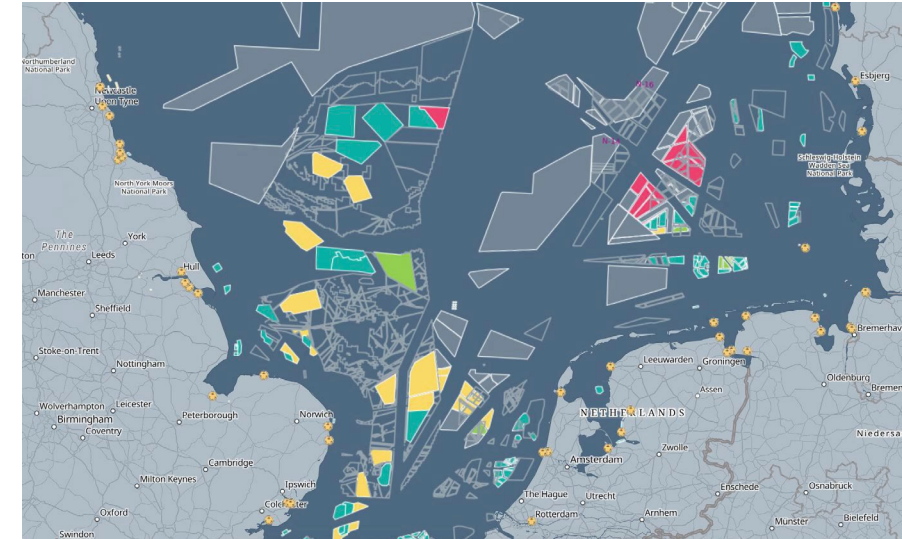

## Contact & Information

Contact person: Pierre-Elouan Réthoré Mail:

[pire@dtu.dk](mailto:pire@dtu.dk)

Division/Company: Wind and Energy Systems

Master thesis: X

What is the uncertainty inherent in modelling the effect of hills, using standard industry parameterization?

- Involves:
  - Sensitivity analysis of WASP flow model
  - Monte-Carlo simulation (via pyWASP)
  - Map resolution effects

## Keywords

- Wind resources
- Uncertainty quantification (UQ)
- Computational (python)
- Roughness length
- Surface description

## Contact & Information

Contact person: Mark Kelly  
(+E.Brizuelo, B.Olsen, R.Floors)  
Mail: [MKEL@dtu.dk](mailto:MKEL@dtu.dk)

Division: Wind and Energy Systems  
Master thesis project: X

# What is the interaction between the sea surface and the offshore wind conditions?

One of the challenges encountered in the wind energy research is the modelling of the sea-surface atmosphere interaction. The **learning objectives** of this project are to **analyse** wind lidar data to **assess** the impact that the sea state has on the offshore wind profiles.

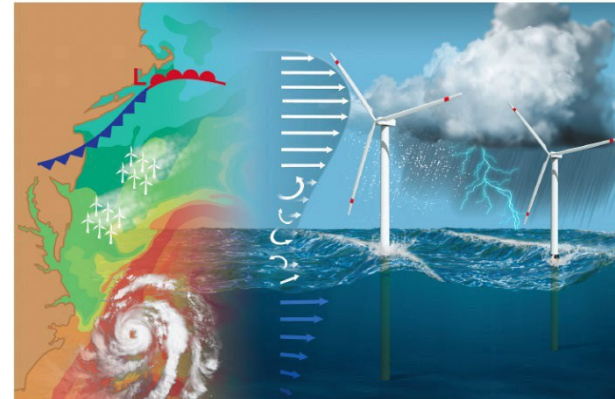
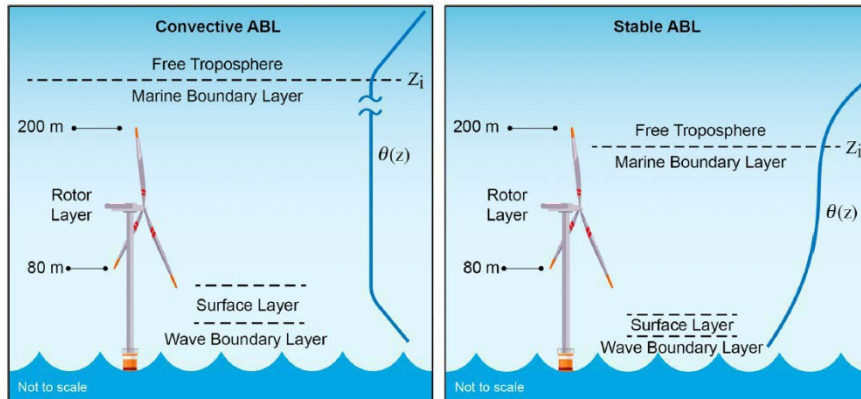

## Figure

Illustrations of the characteristics of the offshore atmospheric boundary layer (left) and the impact that these characteristics have on the wind profile. Figure from Shaw et al. *Scientific challenges to characterizing the wind resource in the marine atmospheric boundary layer*, *Wind Energ. Sci.*, 7, 2307–2334, <https://doi.org/10.5194/wes-7-2307-2022>, 2022.

## Keywords:

- Sea-surface atmosphere interaction
- Offshore conditions
- Wind profile
- Wind lidar
- Experimental observations

## Contact & Information

Contact person: Alfredo Peña /  
Nikolas Angelou

Mail: [aldi@dtu.dk](mailto:aldi@dtu.dk) / [nang@dtu.dk](mailto:nang@dtu.dk)

Division: Wind and Energy System

Master thesis: X

Bachelor project: X

Can be both: X

Wind Assisted Ship Propulsion (WASP), utilized different concepts, like Flettner rotors, wing sails, kites and more to utilize the wind and provide additional thrust for ships. This can help reduce fuel use and GHG emissions. The International Maritime Organization has set the target for net-zero emissions by 2050. This has increased interest in WASP. It is only natural, that DTU Wind Engineers can apply their skills to help this burgeoning field.

Happy to support a variety of different projects:

- Ship sail aerodynamic modelling
- Investigations on wind propulsion technologies
- Optimal weather routing, using optimization to steer the ship for maximum wind utilization
- Design optimization of WASP
- Potential collaboration with DTU construct on Hydrodynamic design and Propeller design

Project details figured out in discussion, please contact Michael K. McWilliam ([mimc@dtu.dk](mailto:mimc@dtu.dk)) for details

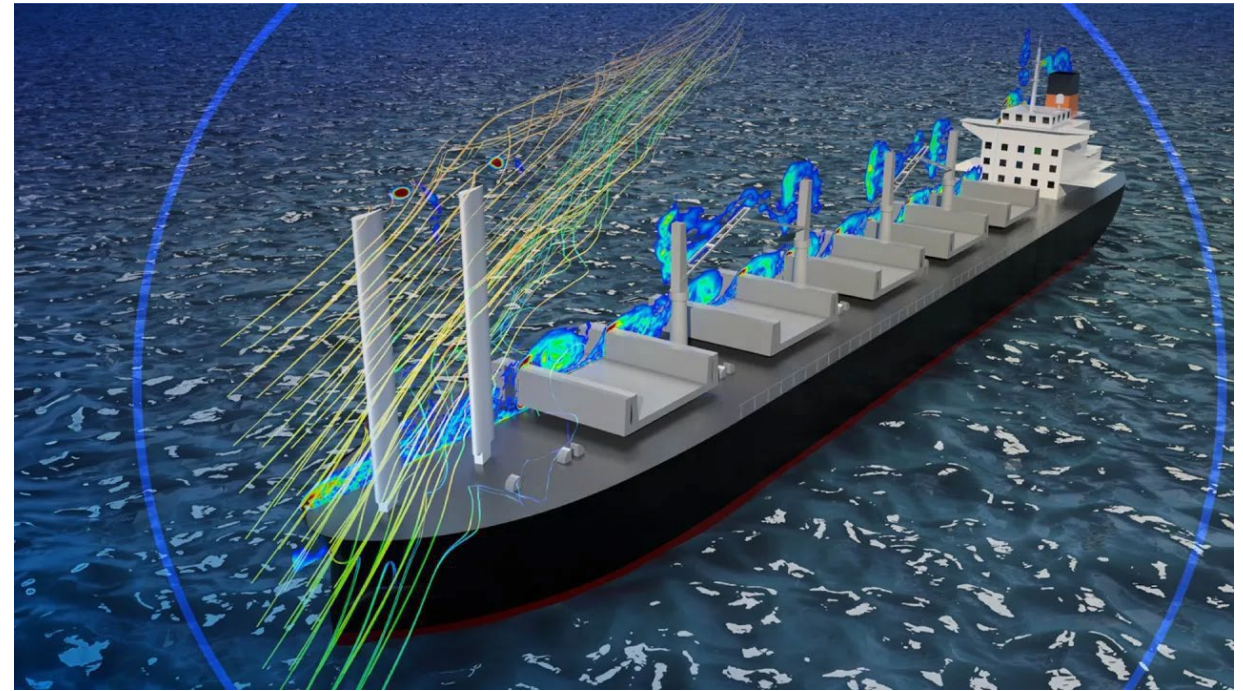

## Keywords

- Maritime Engineering
- Aerodynamics
- Sails
- Wind Propulsion
- Programming (Matlab/Python)

## Contact & Information

Contact person: Michael K. McWilliam  
Mail: [mimc@dtu.dk](mailto:mimc@dtu.dk)  
Division: Wind Energy Systems  
Master thesis: X  
Bachelor project: X  
Can be both: X

Short description of the thesis/project idea (include an illustration if relevant)

The European wind industry provided approximately 400,000 direct jobs in 2025. EU growth targets, coupled with a desire for EU manufacturing, could add several hundred thousand more jobs by 2030. Traditional economic input/output approaches to modeling these jobs tend to rely on assumptions about the location of the supply chain and non-wind industry data, which makes them unreliable.

The goal of this project is to focus on the workforce readiness of different EU regions to support the manufacture of specific components. It will not attempt to predict a number of supply chain jobs, but will model the potential for success and the comparative strengths of different regions. The analysis will involve developing spatially resolved, component-specific workforce readiness metrics that are based on publicly available data. These metrics can be calibrated against historical job data, literature, interviews, and other indicators about the potential for different regions to participate in elements of the wind energy supply chain. The project will compare workforce readiness scores with social acceptance data, planned deployment, and/or existing supply chain to provide insight into areas where job creation could help to overcome resistance to wind energy deployment. Analysis will be conducted for at least one EU or EU adjacent country, with some consideration of data availability for the remainder of the EU.

## Keywords

Workforce readiness  
Metric development  
Spatial analysis  
Impact assessment

## Contact & Information

Contact person: Matt Shields

Mail: [mcs@dtu.dk](mailto:mcs@dtu.dk)

Division: Wind and Energy  
Systems

Master thesis: X

I am happy to support a projects on a variety of different topics in Optimization. Optimization is a numerical process of finding the best design, given an objective (e.g. minimize costs), subject to constraints (e.g. loads). One can apply it for the following:

- Aerodynamic rotor design
- Blade structure design
- Offshore support structure design
- System optimization

There are also a variety of interesting and advanced methods that are fun to explore

- Multi-fidelity optimization (using simple or complex models to enhance the optimization)
- Stochastic optimization (taking into account the uncertainty in the optimization)
- Multi-disciplinary optimization (optimizing more aspects of the system at the same time)

Project details figured out in discussion, please

contact Michael K. McWilliam ([mimc@dtu.dk](mailto:mimc@dtu.dk)) for details

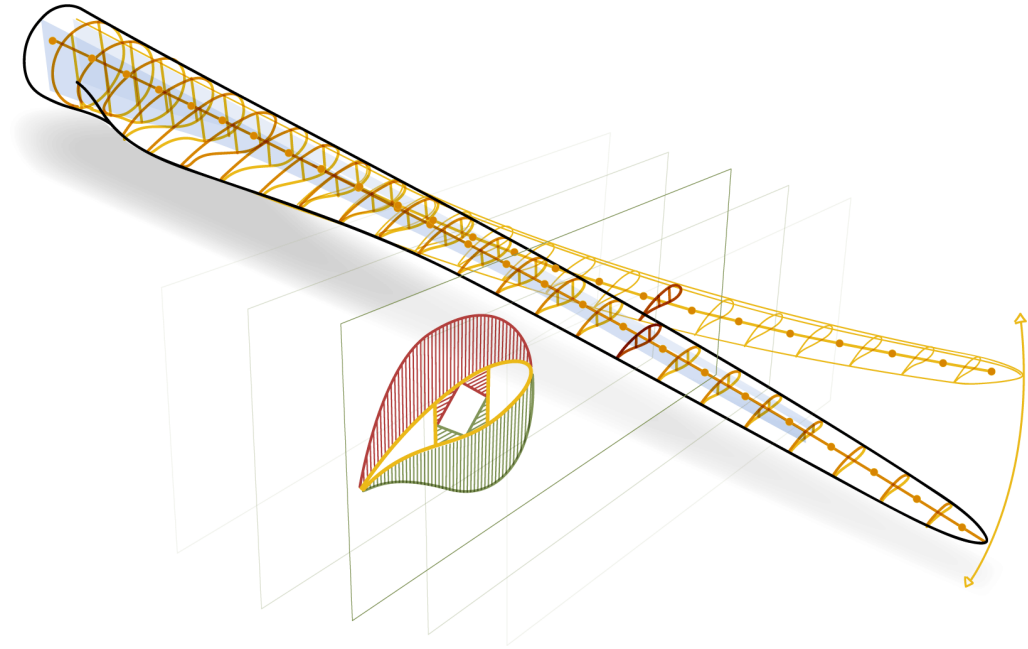

## Keywords

- Design Optimization
- Structural Dynamics
- Aerodynamics
- Blade Design
- Offshore Support Structure Can be both: X

## Contact & Information

Contact person: Michael K. McWilliam  
Mail: [mimc@dtu.dk](mailto:mimc@dtu.dk)  
Division: Wind Energy Systems  
Master thesis: X  
Bachelor project: X

# **Wind Energy Materials and Components (WMC)**

## **What do we do at WMC division?**

We develop solutions for wind energy to become more sustainable, increasing the manufacturing capacity and quality to meet the green transition goals.

## **Why is research on materials and components important?**

Materials are at the core of wind turbines, affecting key properties like weight, duration, performance or environmental footprint. Materials also play a key role in the manufacturing processes.

The main components of wind turbines (blades, drive trains, towers, foundations,...) have a key role in the overall performance of wind turbines, allowing for higher efficiency and cost reductions when the right choices are made during the design phase.

Our research focuses on developing design tools that industry is using for their new components and material systems. The research also focuses on developing innovative testing methods that are used to validate the design tools and industry new products (materials, blades, ...).

## **What can you experience as student working in WMC?**

As a student you will have the opportunity to join projects with industry where research is focused on solving real problems. Our long-term partnerships with the key industry players in win energy allow our students to have an insight and training into the areas industry (wind turbine manufacturers and wind farm developers) are working today.

You will have access to design tools and innovative software that can be used to solve concrete problems while exploring new solutions. Our tools include structural blade design, AI based inspection methods for the detection of blades damage, X ray tomography to look into microscale failure mechanisms, models to calculate remaining life of components, etc.

On top of a cutting-edge suite of tools you will also have access to some of the best laboratories that we se every day to test from the microscale to full scale blades.

You will also have access to some of the top scientists, development engineers and technicians with a very long track record and a very friendly attitude.

Natural fibres like hemp, flax, and sisal are increasingly considered for reinforcing composites in structural applications, such as wind turbine blades. These fibres offer good mechanical properties, such as stiffness and strength, while less dense than traditional fibres like glass or carbon. However, testing their mechanical properties remains challenging, especially in determining their cross-sectional area due to their irregular shape and hollow structure (see the figure below ).

In the Materials Lab at DTU Wind Energy, Risø campus, a semi-automated single fibre testing machine is used for mechanical testing of fibres. An in-built vibroscope technique is used to determine the fibre cross-sectional area based on vibration theory for a tensioned beam. The single fibre testing method at DTU Wind Energy is well-developed and successfully used for glass and carbon fibres. Now, the method needs to be developed for natural fibres.

The MSc. thesis project will cover experimental work of testing fibres with different machine settings, in addition to the required further development of the vibration theory to meet the characteristics of natural fibres.

**Keywords:**

- Natural fibres
- Mechanical testing
- Cross-sectional area
- Vibration theory

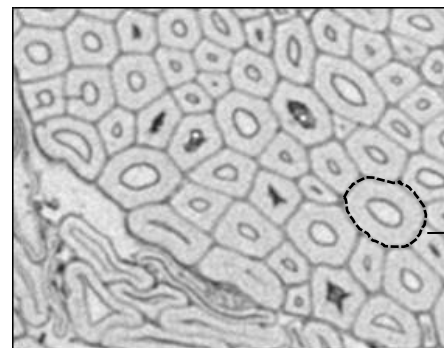

Typical cross-section of natural fibres

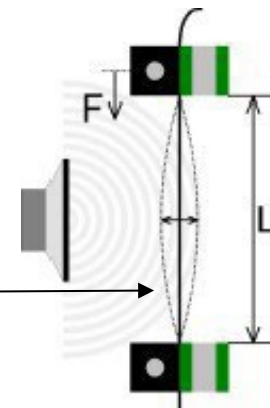

Vibroscope measurement

**Contact & Information**

Contact person: Bo Madsen, Rajnish Kumar  
Mail: [boma@dtu.dk](mailto:boma@dtu.dk) and [rakum@dtu.dk](mailto:rakum@dtu.dk)  
Division/Company: Wind Energy Materials and Components  
Master thesis: X

# Cohesive Zone Modelling of transition from stable to unstable crack propagation:

**Objective:** Predict the transition from stable to unstable delamination crack using advanced cohesive zone model implemented in ABAQUS.

## Project description:

1. Create FEM model of a double cantilever beam using a Cohesive Zone Model
2. Use a combined analytical-numerical approach to predict the transition from stable to unstable crack propagation (catastrophic failure)
3. Carry out parameter study to identify key cohesive parameters driving unstable crack propagation

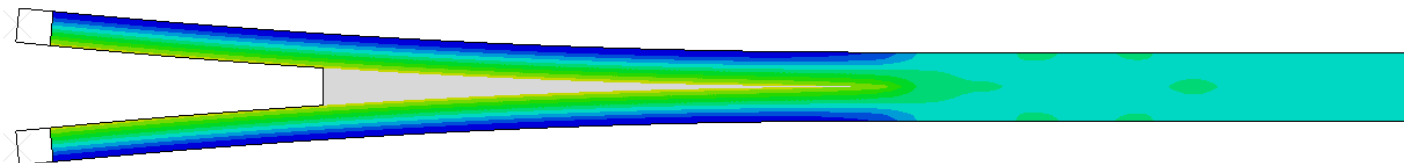
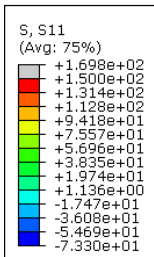

**Keywords:** finite element modelling (FEM), Cohesive zone modelling (CZM), ABAQUS,

**Requirements:** basic understanding of fracture mechanics, and basic knowledge of finite elements (FE)

## Contact & Information

Contact person: Rubén I. Erives

Mail: [riea@dtu.dk](mailto:riea@dtu.dk)

Division: Wind Energy Materials and Components

Master thesis: X

Thermal residual stresses occur during manufacturing and exist in most structures. They are generally something one would like to avoid, since they can lead to premature failures if not understood. What if we could actually tailor the residual stresses and utilize them to make an interface act strong while in-use and weak when separation is desired?

In this master project, you will use finite element modelling to test out the concept of utilizing residual stresses to control interfacial behavior. The project will consider:

- **Develop a finite element model** of a DCB specimen with layers of different materials and thermal residual stresses
- Use FE model to **demonstrate that residual stresses can be controlled** by designing a suitable the layer and material combination
- Use FE model to **demonstrate that the same specimen with residual stresses can act strong** under certain loading conditions **and weak** in others
- **Assessment of the feasibility** of controlling and utilizing thermal residual stresses in real applications

## Keywords:

- Finite element modeling, Interfaces, Fracture mechanics, Thermal residual stresses, Composites

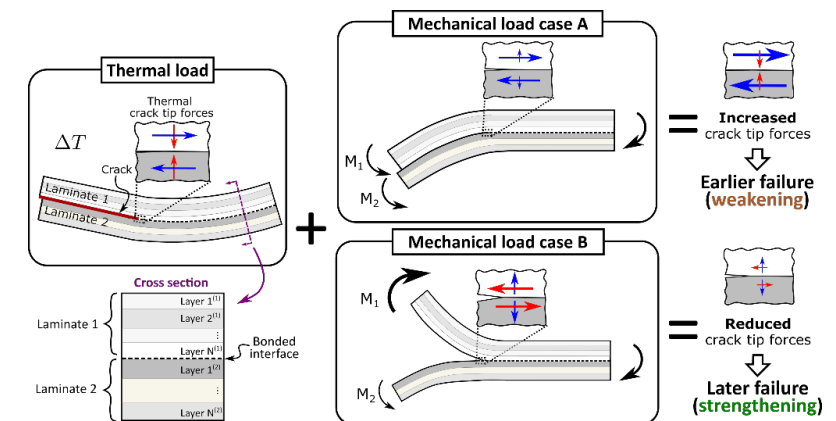

## Contact & Information:

Contact person: Kristine M. Jespersen

Mail: [kmun@dtu.dk](mailto:kmun@dtu.dk)

Division: Wind Energy Materials and Components

Master thesis: X

# Crack growth simulation for wind turbine bearings

Blade bearings of wind turbines can crack their rings

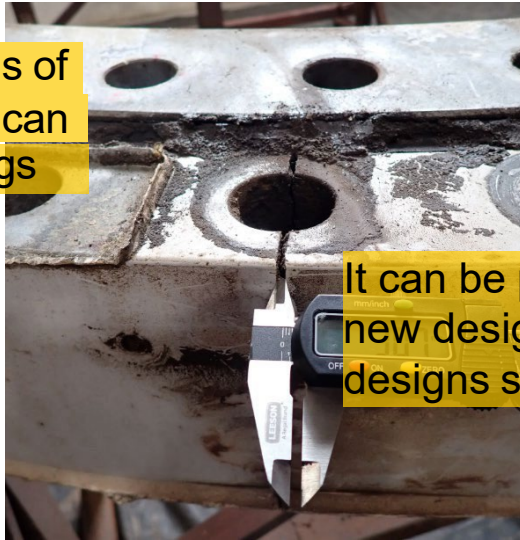

It can be prevented with new designs, but older designs still have issues

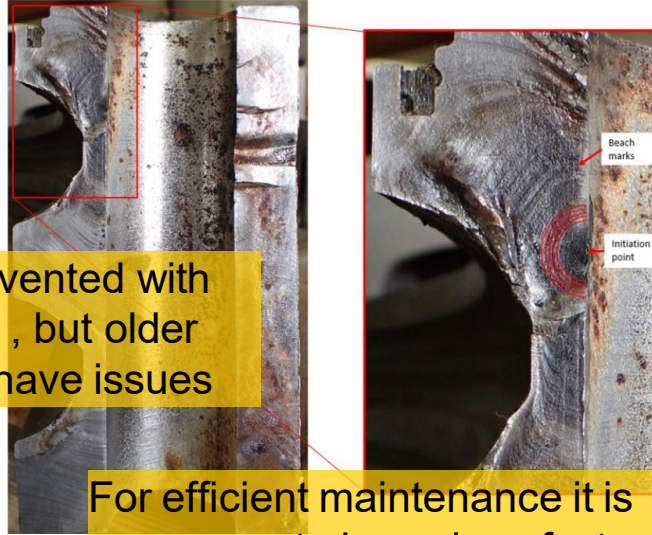

For efficient maintenance it is necessary to know how fast the cracks grow

We got the understanding of load distribution, bearing geometries, and load cycles



- Now it's your turn:
- Use an internship at Vestas to learn about blade bearings
  - Set up a local model in Abaqus to calculate crack growth under a realistic load cycle

**FE Analysis**  
**Mechanical design**  
**Non-linear**  
**Fatigue design**

I got 12 years of experience in pitch bearing research and authored the guideline on their design (DG03). I have supervised 30+ MSc and BSc theses. I will give you guidance and support and nudge in the right direction if you get lost on the way.

**Contact & Information**  
 Contact person: Matthias Stammler  
 Mail: [masta@dtu.dk](mailto:masta@dtu.dk)  
 Division: Wind energy materials and components  
 Master thesis: X

# Damage tolerant structural design by shape optimization of wind turbine blade structures

**Objective:** Optimization of structural details for damage tolerant designs of large composite structures e.g., wind turbine blades

## Project description:

1. Create finite element model of structural detail using a Cohesive Zone Model
2. Use a combined analytical-numerical optimization of structural detail to minimize the external energy release rate of different designs
3. Carry out parameter study to identify key cohesive parameters driving unstable crack propagation

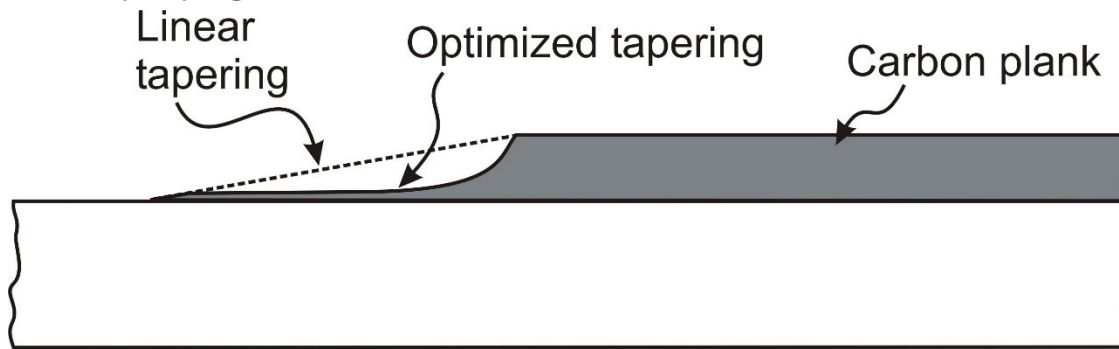

PlankDrop\_Optimal\_1a.cdr

**Keywords:** FEM modelling, CZM, ABAQUS, Fracture mechanics, optimization, wind turbine blade

**Requirements:** basic understanding of fracture mechanics, and basic knowledge of finite elements (FE)

## Contact & Information

Contact person: Bent F. Sørensen

Mail: [bsqr@dtu.dk](mailto:bsqr@dtu.dk)

Division: Wind Energy Materials and Components

Master thesis: X

# Design exploration of a coning pitch bearing

BOTH

What if a wind turbine can lean into the wind?

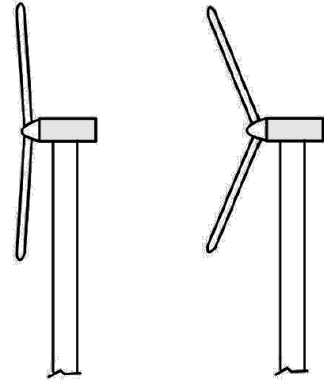

Aerodynamic and control engineers would be



Costs of energy would be



- Disruptive technology**
- Mechanical design**
- Risk analysis**
- 3D visualization**

I got 12 years of experience in pitch bearing research and authored the guideline on their design (DG03). I have supervised 30+ MSc and BSc theses

I will give you guidance and support and nudge in the right direction if you get lost on the way.

We got the concept for a pitch bearing that could do it:

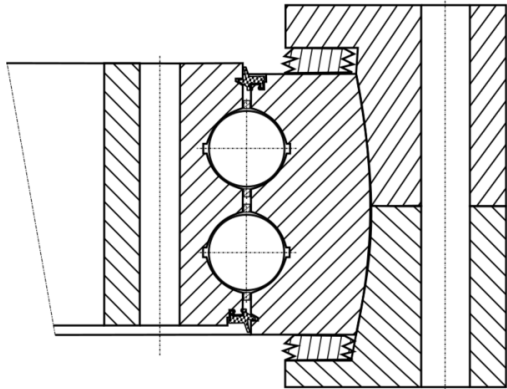

- Now it's your turn:
- Use 3D tools to make a more detailed design
  - Explore possible materials
  - Evaluate risks
  - Plan tests on large test rigs

**Contact & Information**  
 Contact person: Matthias Stammler  
 Mail: [masta@dtu.dk](mailto:masta@dtu.dk)  
 Division: Wind Energy Materials and Components  
 Master thesis: X  
 Bachelor project: X  
 Can be both: X

# Design of light-weight loading arms for fracture mechanics test

The double cantilever beam test with uneven bending moments (DCB-UBM) allows to test the strength of an interface at many different combinations of shear and normal loading near the crack tip (mode mixities). This is important for accurate modelling of interfaces in structures such as wind turbines. However, the current experimental setup suffers from heavy aluminium arms used to apply the bending moment loading. This can lead to an unintended pre-loading of the specimen, which should be avoided.

In this master project, you will use finite element modelling to design new light-weight (e.g. carbon fibre composite) loading arms for the DCB-UBM test setup. The project will consider:

- **Make 3D CAD drawings** of the loading arm design candidates
- **Develop a finite element (FE) model** of the load arms
- Utilize developed FE model to **compare different loading arm designs**
- Utilize developed FE model to **examine suitable materials and lay-up** for the arms

The expected outcome of the project is to provide sufficient details of the design of new loading arms to be able to be put into production after the project is finished.

## Keywords:

- Finite element modeling
- Carbon fibre composite
- Fracture mechanics testing
- CAD drawing
- Experimental design

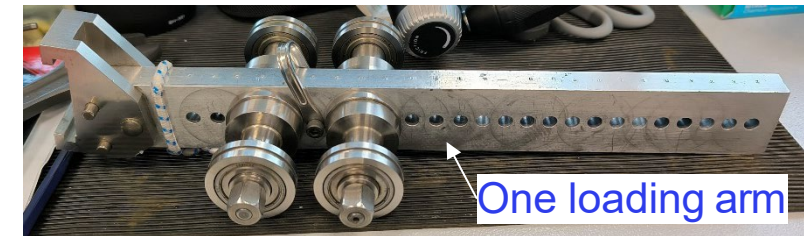

## Contact & Information:

Contact person: Kristine M. Jespersen

Mail: [kmun@dtu.dk](mailto:kmun@dtu.dk)

Division: Wind Energy Materials and Components

Master thesis: X

# Experimental: Comparative Analysis of Blade Material Durability Using Whirling Arm Rain Erosion Facility

- **Background:** Wind turbine blades are subject to various atmospheric conditions, with rain erosion being one of the leading factors affecting their durability and efficiency. The collaboration between DTU Wind Energy and Fraunhofer IWES provides an exclusive opportunity to utilize advanced testing facilities - the new whirling arm rain erosion facility at DTU and the erosion tester at IWES - aiming to innovate blade materials for enhanced durability in harsh environmental conditions.
- **Purpose:** This project seeks to understand the erosion mechanisms affecting wind turbine blades, compare the efficacy of different protective coatings and materials, and analyze their performance under simulated high-velocity rain conditions, contributing to the development of more resilient wind turbines.

## Contents:

- **Conducting Tests** - Perform erosion tests one or both facilities
- **Data Analysis and Interpretation** - Analyze data to assess material performance, erosion rates, and effectiveness of protective coatings under different conditions.
- **Methods:** This project will involve experimental research methods, utilizing the advanced testing facilities at both DTU and IWES. Statistical analysis is crucial for interpreting test results and drawing valid conclusions.
- **Expected Results:** A clearer understanding of how different blade materials and protective coatings withstand rain erosion, providing an empirical basis for recommendations on material innovation for industry application.

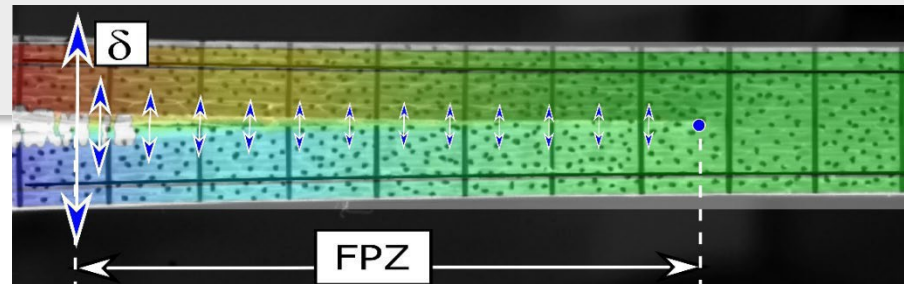

**Keywords:** Wind Turbine Erosion, Blade Material Durability, Rain Erosion Simulation, Erosion Protective Coatings, Whirling Arm Testing

**Requirements:** basic knowledge of programming,

## Contact & Information

Contact person: Nicolai Frost-Jensen Johansen

Mail: [Nijoh@dtu.dk](mailto:Nijoh@dtu.dk)

Division/Company: Wind Energy Materials and Components

Master thesis: X

**Objective:** Plan and conduct fracture mechanics test and use digital image correlation analyses to estimate the fracture resistance of a material in terms of the J-integral.

## Project description:

1. Plan fracture mechanics tests for DCB specimens subject to un-even bending moments
2. Instrument setup with high resolution cameras for digital image correlation.
3. Analyze images and loads from experiments to obtain fracture resistance as a function of delamination crack openings
4. Compare results with analytical approaches

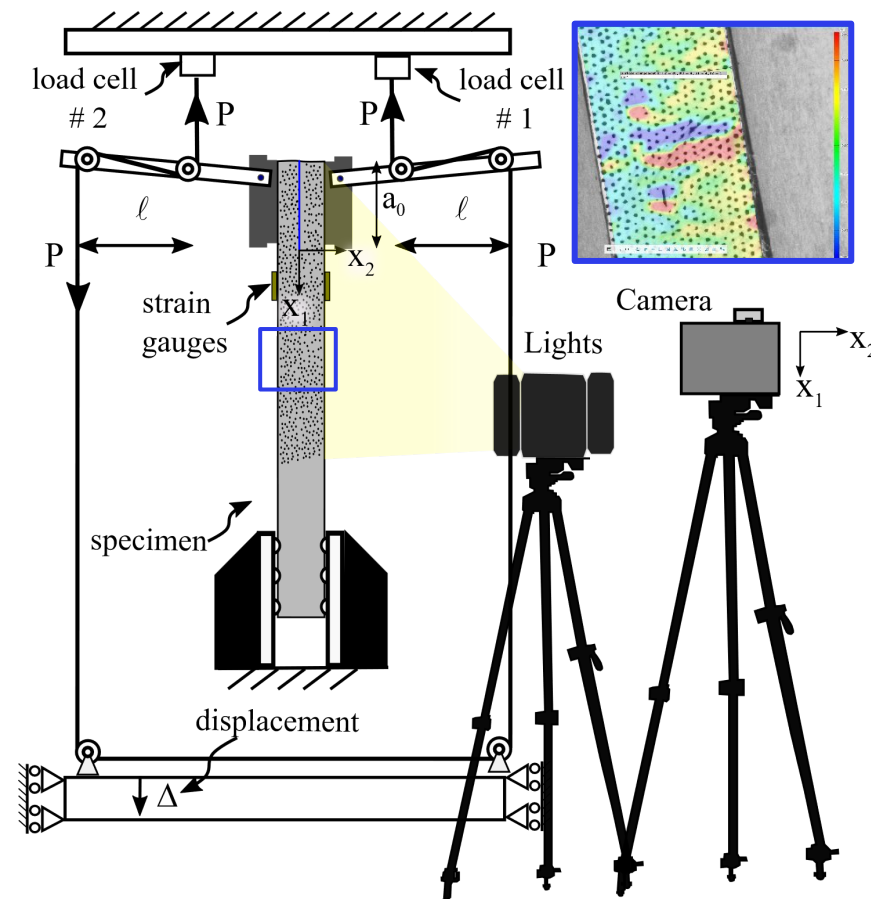

**Keywords:** Digital image correlation, Fracture mechanics testing, wind turbine blade, Experimental

**Requirements:** basic understanding of fracture mechanics

## Contact & Information

Contact person: Bent F. Sørensen

Mail: [bsqr@dtu.dk](mailto:bsqr@dtu.dk)

Division/Company: Wind Energy Materials and Components

Master thesis: X

# Experimental: In-situ measurements of fracture resistance using digital image correlation from SEM

**Objective:** Plan and conduct *in-situ* fracture mechanics test at the scanning electron microscope (SEM) to record high magnification images and use digital image correlation (DIC) analyses to estimate the fracture resistance of a material in terms of the J-integral.

## Project description:

1. Plan in-situ fracture mechanics tests at the scanning electron microscope for small scale DCB specimens
2. Analyze images using digital image correlation (DIC) technique and loads from experiments to obtain fracture resistance as a function of crack openings
3. Carry out experiments with asymmetric specimens and compare results with analytical results

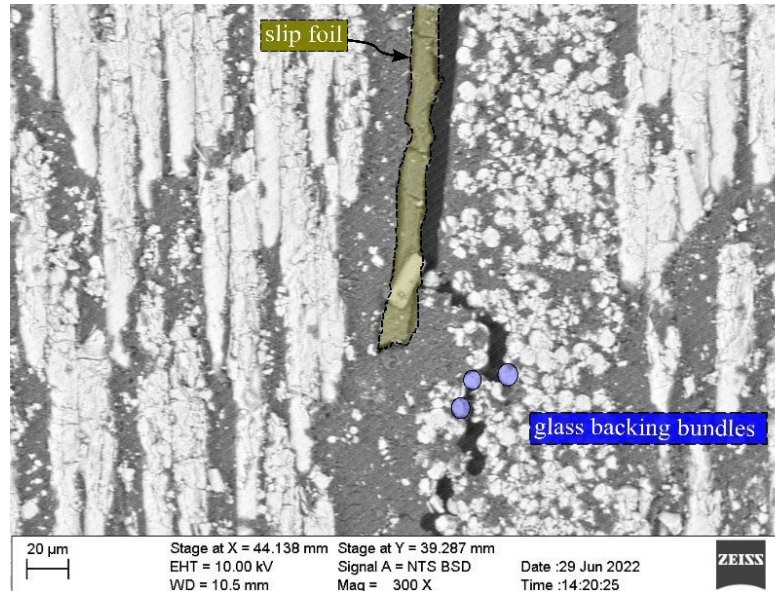

**Keywords:** Digital image correlation, fracture mechanics, micro-mechanics testing, scanning electron microscope (SEM)

**Requirements:** basic understanding of fracture mechanics

## Contact & Information

Contact person: Bent F. Sørensen

Mail: [bsqr@dtu.dk](mailto:bsqr@dtu.dk)

Division/Company: Wind Energy

Materials and Components

Master thesis: X

- Leading edge erosion of wind turbine blades is a severe problem for wind power generation. The blade surfaces erode due to collisions with rain droplets, hail stones and other airborne particles. It leads to degradation of the aerodynamic efficiency, loss of power generation, and expensive repairs.
- Fatigue cracking is a prominent damage mode in elastomer based leading edge protection (LEP) systems.
- The purpose of this project is to characterize fatigue crack growth thresholds in leading edge materials for a range of loading rates and temperatures.

## Keywords:

- Wind energy
- Turbine blade erosion
- Fracture mechanics
- Experimental characterization
- Materials science

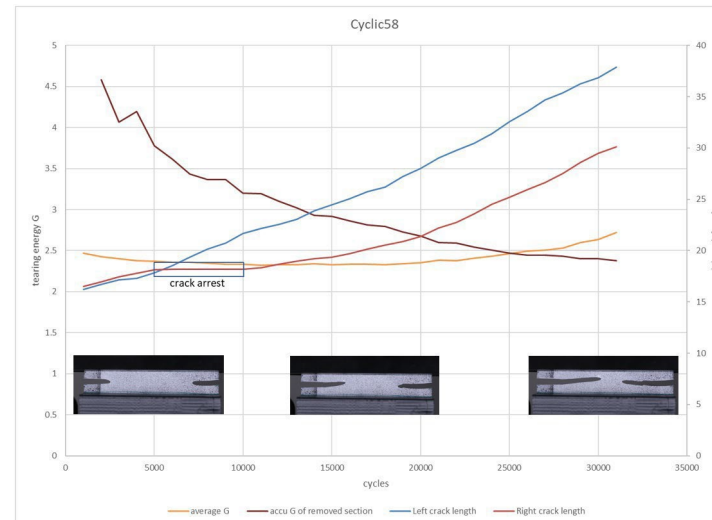

## Contact & Information

Contact person: Jakob I. Bech

Mail: [jakb@dtu.dk](mailto:jakb@dtu.dk)

Division: Wind Energy Materials and Components

Master thesis: X

# Fatigue resistance of corroded 42CrMo4 steel

Blade bearings of wind turbines can crack their rings

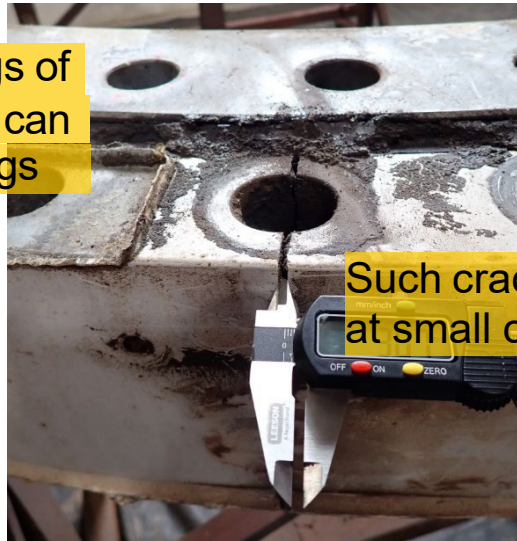

Such cracks often initiate at small corrosion spots

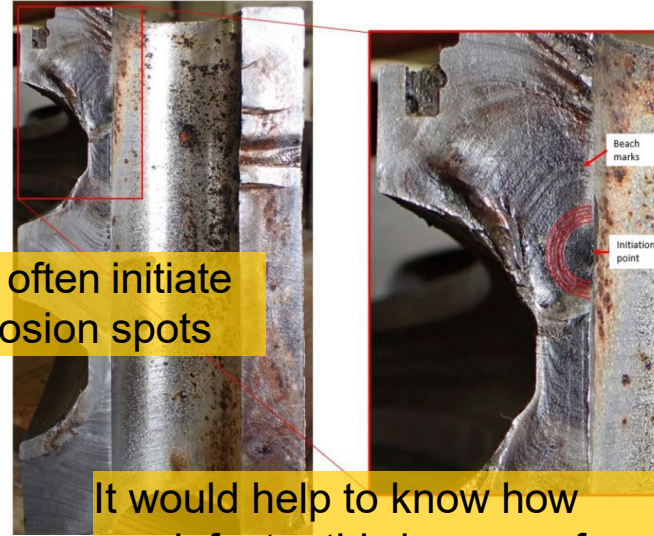

It would help to know how much faster this happens for typical bearing steel

Now it's your turn:

- Use an internship at Vestas to learn about blade bearings and their materials
- Prepare corroded samples of 42CrMo4 steel and test them at DTU's material tests labs
- Calculate S/N curves

**Mechanical design**  
**Material tests**  
**Fatigue design**

I got 12 years of experience in pitch bearing research and authored the guideline on their design (DG03). I have supervised 30+ MSc and BSc theses

I will give you guidance and support and nudge in the right direction if you get lost on the way.

## Contact & Information

Contact person: Matthias Stammer

Mail: [masta@dtu.dk](mailto:masta@dtu.dk)

Division: Wind energy materials and components

Master thesis: X

# Investigating dynamic effects of steel beams used in a DCB-UBM test setup

## Project Background:

For characterization of crack growth under various mode mixities, viz., Mode I, Mode II and Mixed mode, we commonly use DCB-UBM (Double Cantilever Beam loaded with Uneven Bending Moments) specimens. Figure towards the right shows a schematic representation of the test setup and how uneven bending moments (UBM) are applied to the test specimen. By using transverse arms, currently made of steel and a cable/roller arrangement, identical forces are generated at the arms as shown. The arms are attached to the ends of the DCB specimen. The moments are then controlled by the moment arms, i.e., the distance between the forces,  $l_1$  and  $l_2$ .

## Objective:

To study the inertia effects of transverse steel arms and other parts of the test machine (like springs, rollers etc.) that can lead to unwanted vibrations during cyclic loading of DCB-UBM specimens when tested under different frequencies. The main aim is to build a model and analyze the test set-up from the perspectives of dynamics:

- **Can the transverse arms be made of light weight material**
- **Explore alternative material options like wood, fibre composites etc.**
- **Knowing the operational limits of the test setup (ex. maximum frequency during cyclic loading)**

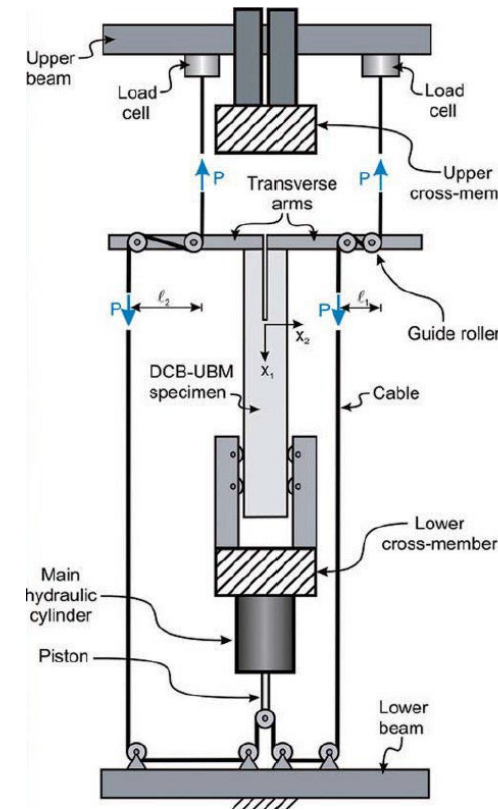

## **Keywords:**

- Inertia effects
- Dynamics of machines
- Vibrational analysis
- Strength and stiffness

## **Contact & Information:**

Contact person: Ashish K. Bangaru

Mail: [akba@dtu.dk](mailto:akba@dtu.dk)

Division/Company: Wind Energy  
Materials and Components

Master thesis: X

# Micro Mechanical Properties and Failure Modes of Carbon Fiber Pultrusions: Influence of Fiber Geometry

- Carbon pultrusions are the industry standard in wind turbine blades due to their exceptional strength-to-weight ratio, stiffness, and fatigue resistance. The performance is due to an almost perfect fiber alignment. However, the mechanical behavior and failure mechanisms of these materials are complex and highly dependent on the microstructural characteristics of the fibers and the composite architecture.
- This project aims to investigate the micro-mechanical properties and failure modes of carbon fiber pultrusions, with a particular focus on how variations in fiber geometry influence these properties. Of particular interest are non-circular fiber cross-sections—such as trilobal geometries—and their potential enhancement of the mechanical performance of pultrusion compared to traditional circular fibers
- The project will be conducted together with a leading wind turbine manufacturer

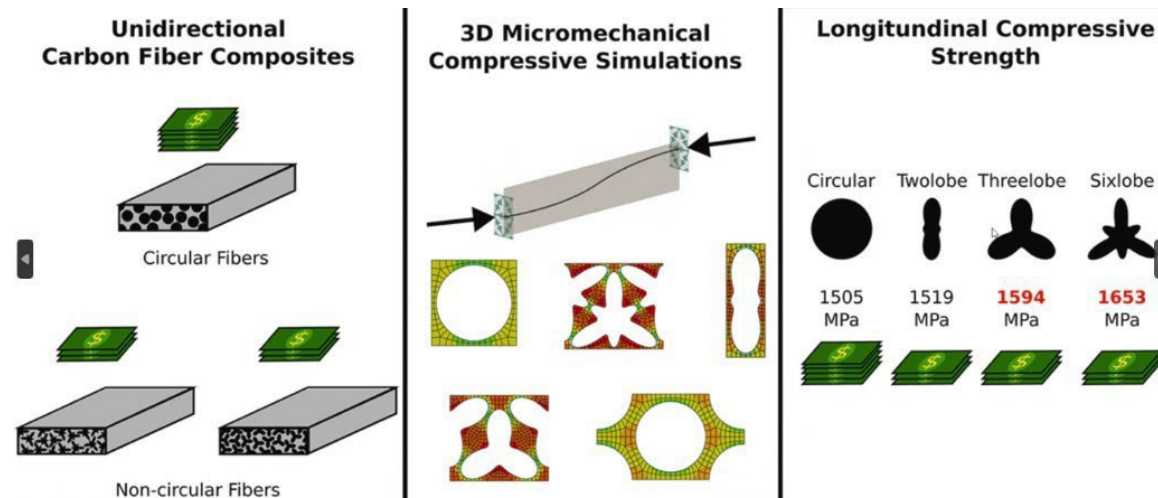

Reference: <https://doi.org/10.1016/j.compscitech.2023.110168>

## Contact & Information

Contact person: Lars P. Mikkelsen, C.F. Niordson

Mail: [lapm@dtu.dk](mailto:lapm@dtu.dk) and [cfni@dtu.dk](mailto:cfni@dtu.dk)

Division: Wind Energy Materials and Components

Master thesis: X

# Numerical modelling of carbon fiber wind turbine blade structures

- Carbon fiber reinforced polymer (CFRP) higher specific stiffness vs glass (GFRP)
- XXL blades use CFRP in spar caps -> Industrial relevance
- CFRP has different stiffness in tension vs compression
- DTU has tool called BECAS to calculate beam properties from a cross-section using 2D FEM
- The aim is to include this non-linearity in numerical modelling using BECAS

## Keywords:

- ❖ Wind turbine blades
- ❖ Carbon fiber
- ❖ Numerical modelling

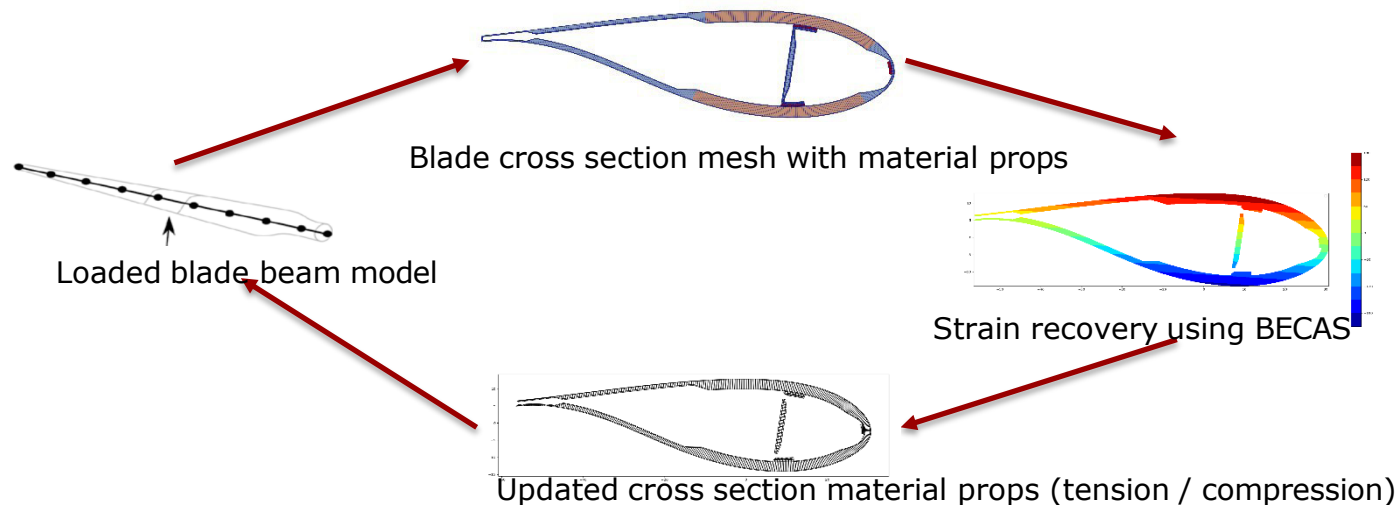

## Contact & Information

Contact person: Mathijs Peeters  
Mail: [matpee@dtu.dk](mailto:matpee@dtu.dk)  
Division: Wind Energy Materials and Components  
Master thesis: X

# On demand bonding and debonding of interfaces by friction

Have you ever riffle-shuffled a deck of cards then tried to pull the two stacks apart while still holding the stacks and wondered why it was so difficult? However, you can easily take the cards apart again if you just simply lift them off. The answer is friction combined with applied pressure. After taking the cards apart, one can easily shuffle them together again with the same or a different stack of cards. Here, the key mechanism is friction between the cards. What if we could utilize similar mechanisms for composite materials used for future wind turbine blades?

In this master project, you will use finite element modelling to test out a **new bonding method** inspired by the card shuffling example that can easily be debonded and bonded again multiple times. The project will consider:

- **Develop a finite element model** with multiple layers including friction
- Consideration of **designing a suitable transition** between the layers allowing for production
- **Carry out parametric studies** on the effect of overlap length, applied pressure, and layer height on the bond strength
- **Assessment of the feasibility** of utilizing friction for bonding in real applications

## Keywords:

- Finite element modeling
- Interfaces
- Fracture mechanics
- Friction
- Composites

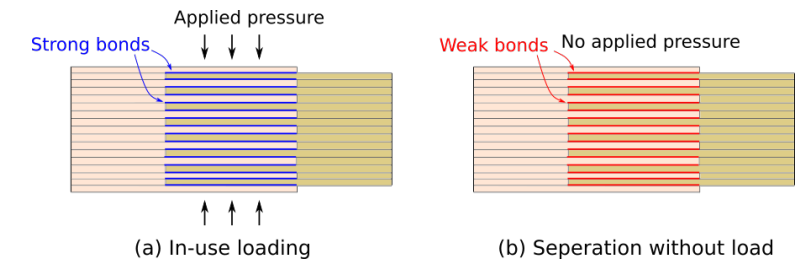

## Contact & Information:

Contact person: Kristine M. Jespersen

Mail: [kmun@dtu.dk](mailto:kmun@dtu.dk)

Division: Wind Energy Materials and Components

Master thesis: X

What if we could design the interfaces between the layers of composite materials in a way where they could be strong in service but weak when we needed to take them apart? And then put them together again in a different stacking sequence for another application?

In this master project, you will use finite element modeling to investigate whether having **alternating weak and strong interfaces** in a **composite material** can be used to obtain a strong interface under certain loading conditions (in-use) and a weak interface when separation is desired. The project will consider:

- **Develop a finite element model** of a layered structure containing a weak and a strong interface e.g. cohesive zone modeling, XFEM or similar
- on the crack propagation **Examine the effect of applying different types of loading**
- **Carry out a parametric study** on how changing the interface properties affect the load carrying capacity at "in-use" and "separation" loading conditions
- **Assessment of the feasibility** of utilizing alternating weak/strong interfaces for "on-demand debonding"

## Keywords:

- Finite element modeling
- Interfaces
- Fracture mechanics
- Cohesive zone modelling
- Composites

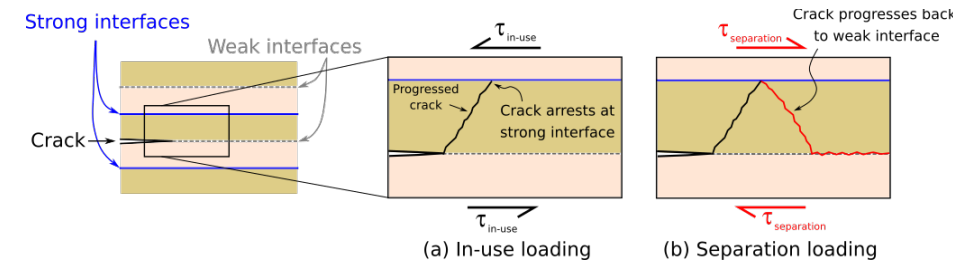

## Contact & Information:

Contact person: Kristine M. Jespersen

Mail: [kmun@dtu.dk](mailto:kmun@dtu.dk)

Division: Wind Energy Materials and Components

Master thesis: X

# Physics-informed machine learning for parameter identification of interface fracture of composite materials

**Objective:** Use physics-informed machine learning methods to fit experimental fracture mechanics data (R-curves) and derive the cohesive behavior or mixed-mode delamination.

**Keywords:** Physics-informed machine learning, surface fitting, Fracture resistance

## Project description:

1. Use existing (direct) machine learning methods (e.g., gaussian process models, neural networks, etc.) to fit the surface of a potential function determined from experimental fracture resistance curves (R-curves).
2. Use different physics-informed machine learning to identify model parameters that best describe the measured fracture resistance, and compare both approaches.

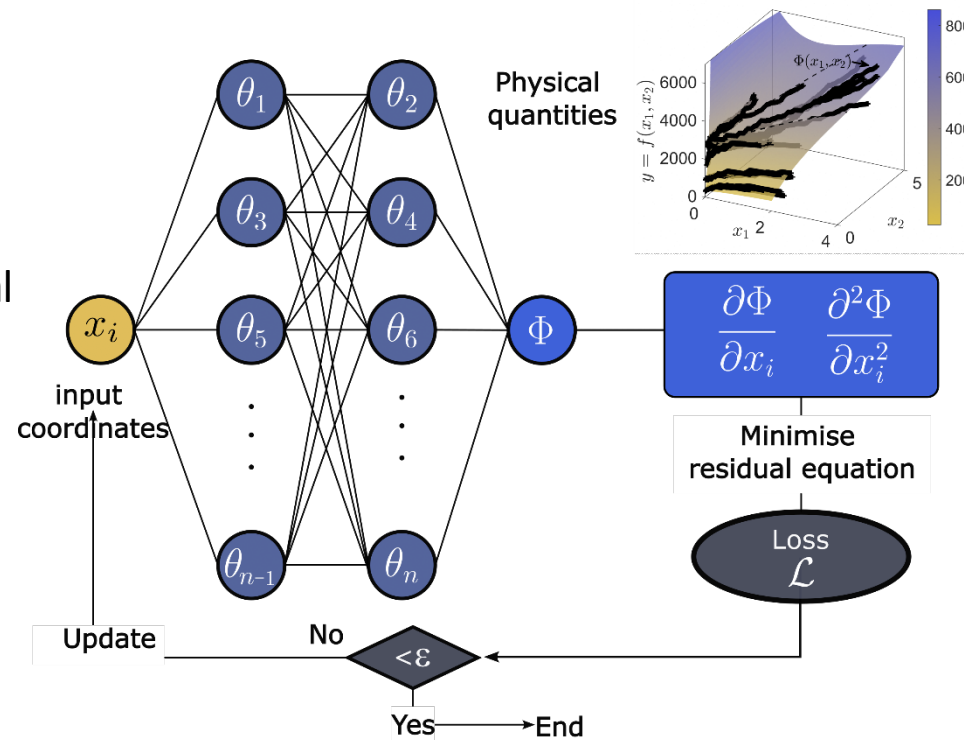

**Requirements:** Basic knowledge of programming, basic understanding of fracture mechanics

## Contact & Information

Contact person: Rubén I. Erives

Mail: [riea@dtu.dk](mailto:riea@dtu.dk)

Division: Wind Energy Materials and Components

Master thesis: X

# Probabilistic modeling of operation and maintenance processes

This thesis aims to advance DTU's **ValueWind** tool, an impact assessment framework that models the technical and economic performance of wind energy assets over their lifetime. The focus is on extending ValueWind's **Operation & Maintenance Module** by integrating asset operation with maintenance modeling.

## Objectives:

- Model failure occurrence and maintenance processes using Markov chains
- Link turbine load response to failure rates (load-to-failure modeling)
- Integrate system state modeling with economic modeling of the maintenance process

## Requirements:

- Understanding of wind energy systems, operation, and economics, understanding of probabilistic methods and reliability
- Python programming skills

**Keywords:** Impact Assessment, Operation & Maintenance, Reliability



## Contact & Information

Contact person: Moritz Gräfe

Mail: [mograf@dtu.dk](mailto:mograf@dtu.dk)

Division: Wind Energy Materials and Components

Master thesis: X

Most mechanical properties of composites depend on the fraction of fibres, matrix and - importantly - porosity. This composition can be measured by ASTM D3171, but the results always depend on the input densities and their uncertainty.

The density of carbon and glass fibres is challenging to measure. At the Materials Lab at DTU Wind Energy, we use a gas pycnometer, where the volume of a fibre sample is related to measurements of gas pressure. This method is well established, and widely used in our collaboration with the composite industry.

However, experience with the device has shown the need for a better understanding of how the pycnometer settings influence accuracy and precision of measurements.

The MSc. thesis project will cover experimental work of measuring the density of fibres under different experimental settings, in addition to theoretical understanding of the operating physical principles, and statistical error analysis.

## Keywords:

- Fractions of fibres, matrix and porosity
- Fibre density
- Pycnometer method
- Accuracy and precision of measurements

## Contact & Information

Contact person: Bo Madsen, Agustin Canalis  
 Mail: [boma@dtu.dk](mailto:boma@dtu.dk) and [aguca@dtu.dk](mailto:aguca@dtu.dk)  
 Division/Company: Wind Energy Materials and Components  
 Master thesis: X

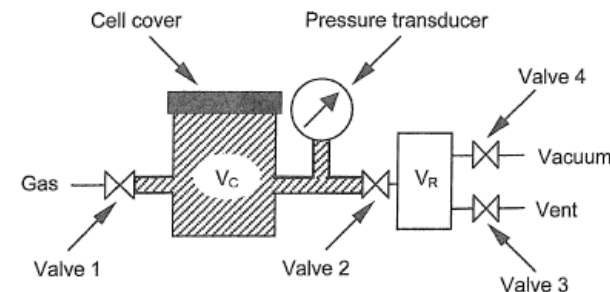
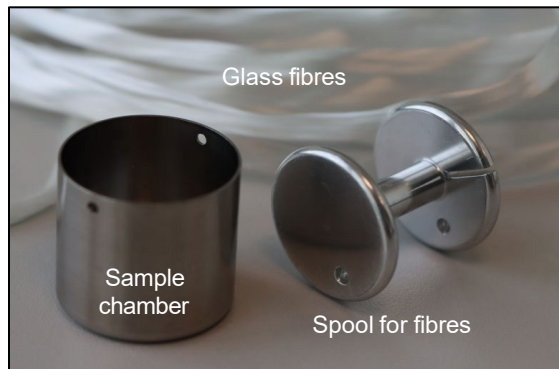

Many European wind turbines are approaching the end of their design life. Decisions on lifetime extension (LTE) or decommissioning must balance structural safety, reliability, and economic and legal feasibility.

## Objectives

Develop a techno-economic model for wind turbine lifetime extension and integrate it into DTU's ValueWind impact assessment tool. Key tasks include:

- Modeling costs of LTE and repowering projects
- Estimating O&M costs during extended lifetime
- Performing risk analysis
- Assessing valuation and economic feasibility

## Requirements

- Understanding of wind energy systems, operation, and economics
- Proficiency in Python programming

## Keywords:

Life time extension,  
Repowering, Project economics,  
Cost modeling



## Contact & Information

Contact person: Moritz Gräfe

Mail: [mograf@dtu.dk](mailto:mograf@dtu.dk)

Division: Wind Energy Materials and  
Components

Master thesis: X

# Understanding crack-tip behavior in composites at the microscale

## Project Background:

The resistance to fracture of fibre composites can be dramatically increased by crack bridging, i.e. fibres that connect crack faces behind the crack tip, a phenomenon that is observed in many tough natural materials. However, for unidirectional fibre composites, delamination cracks growing in the longitudinal direction (i.e., along the fibres) do not generate much crack bridging, since, at the macroscale, cracks do not kink through the layers of fibres irrespective of the modes of loading. This is different from isotropic materials, where cracks always propagate in the direction perpendicular to the direction of the highest principal tensile stress. In composites, at the microscale, matrix cracks kink and align perpendicular to the local maximum principal stress only in resin-rich areas.

## Objective:

The project objective is to understand why, at the macroscale, a longitudinal crack in conventional fibre composites does not kink through layers under Mixed Mode loading:

- **Scanning Electron Microscope (SEM) investigations of tested fracture specimens**
- **Identify locations with narrow and wide fibre spacing including resin-rich pockets**
- **Postulate conditions that produce crack kinking at the microscale**

The expected outcome of the project is to provide microscale details that promote crack kinking/bridging and thereby enhancing the fracture resistance of the fibre composite.

## **Keywords:**

- Unidirectional fibre composites
- Fracture resistance
- Fibre bridging

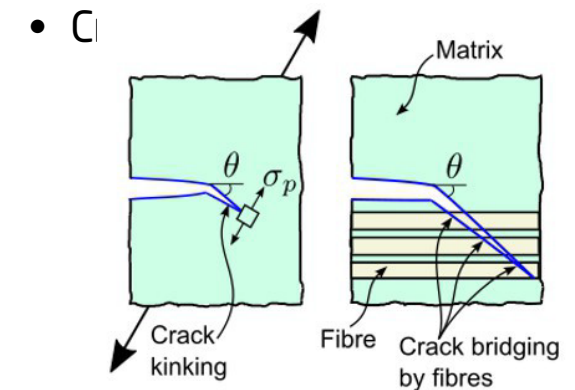

## **Contact & Information:**

Contact person: Ashish K. Bangaru

Mail: [akba@dtu.dk](mailto:akba@dtu.dk)

Division/Company: Wind Energy  
Materials and Components

Master thesis: X

# Wind farm project valuation under different operational strategies and market conditions

This thesis aims to advance DTU's **ValueWind** tool, an impact assessment framework that models the technical and economic performance of wind energy assets over their lifetime. The focus is on extending ValueWind's **revenue assessment module** by integrating country-specific support schemes and market-based pricing mechanisms.

**Keywords:** Wind energy economics, Impact Assessment

## Objectives

- Develop and implement detailed models for country-specific CfD schemes
- Assess revenue performance under varying spot prices, CfDs, and support mechanisms
- Evaluate operational strategies (e.g., greedy control, revenue-based curtailment) and their interaction with support schemes

## Requirements:

- General understanding of wind energy systems, operation & economics
- Python programming skills

References: Kitzing, L., Held, A., Gephart, M., Wagner, F., Anatolitis, V., & Klessmann, C. (2024). *Contracts-for-difference to support renewable energy technologies: Considerations for design and implementation*. European University Institute. <https://doi.org/10.2870/379508>



## Contact & Information

Contact person: Moritz Gräfe

Mail: [mograf@dtu.dk](mailto:mograf@dtu.dk)

Division: Wind Energy Materials and Components

Master thesis: X

- Leading edge erosion of wind turbine blades is a severe problem for wind power generation. The blade surfaces erode due to collisions with rain droplets, hail stones and other airborne particles. It leads to degradation of the aerodynamic efficiency, loss of power generation, and expensive repairs.
- Fracture mechanics offer a novel direction in modelling and analyzing leading edge erosion.
- This project addresses cyclic high strain rate fracture of elastomer based coatings and shielding materials for leading edge protection of wind turbine blades.
- The M.Sc. project will cover the development of a numerical fracture mechanics based model to predict fatigue crack growth thresholds for droplet impact on a leading edge protection material. The model will employ hyper viscoelastic and fracture mechanics properties obtained from mechanical experimental characterization of the impacted material.

**Keywords:**

- Wind energy
- Turbine blade erosion
- Fracture mechanics
- Numerical modelling
- Materials science

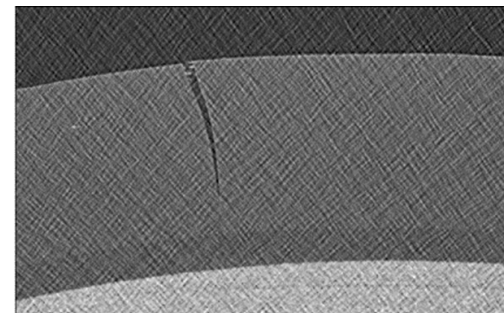
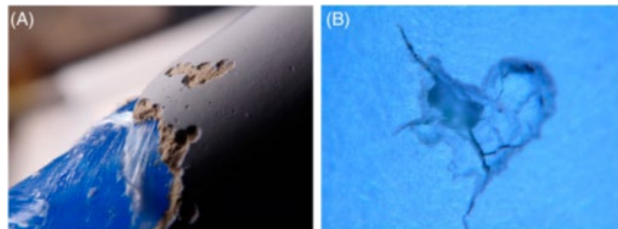
**Contact & Information**

Contact person: Jakob I. Bech

Mail: [jakb@dtu.dk](mailto:jakb@dtu.dk)

Division: Wind Energy Materials and Components

Master thesis: X

# Wind Turbine Blade Thermal Image Super-Resolution and Denoising Using Diffusion Models

## Abstract

Thermal imaging plays a crucial role in various inspection systems, particularly in industrial and environmental monitoring. However, high-resolution thermal cameras are prohibitively expensive, limiting accessibility and scalability. Recent advances in generative AI, specifically diffusion models (DMs), have demonstrated exceptional capabilities in generating high-quality, realistic images. This project aims to develop a diffusion model-based AI framework for enhancing thermal images through super-resolution (SR) and denoising, enabling improved analysis using lower-cost thermal imaging hardware.

## Research Foundation and Resources

- Expertise: The group has a strong background in computer vision and thermography
- Data: Extensive thermal image dataset from wind turbine inspections
- Hardware: Access to various thermal cameras: Optris PI 640i, FLIR A655sc, ...

## Candidate Requirements

- Experience in Computer Vision, Deep Learning, and Python
- Experience with DMs/thermal imaging/image SR is a plus
- Academic writing skills are beneficial

## Find out more about our recent project

- Scan the QR code

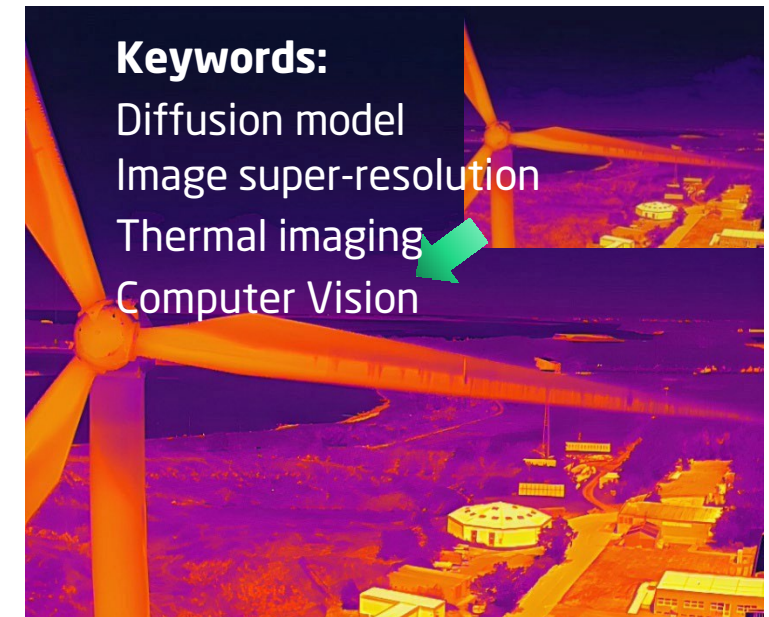
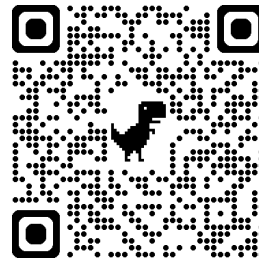

## Contact & Information

Contact person: Xiaodong Jia / Xiao Chen/ Hans-Henrik von Benzon

Mail: [xiaj@dtu.dk](mailto:xiaj@dtu.dk)

Division: Wind Energy Materials and Components

Master thesis: X

# Wind Turbine Design (WTD)

## Rotor and airfoil design

- Engineering aerodynamics
- Aerodynamic validation
- Aerodynamic rotor design and optimization
- Aerodynamic control
- Airfoil design

## Aero- and fluid dynamics

- Numerical fluid mechanics
- Aero acoustics, noise emission modelling
- CFD tools
- Fluid-structure modelling
- Hydrodynamics
- Wave and current loads modelling and validation

## Turbine response and control

- Dynamics
- Aero-elasticity
- Load models and validation
- Control models and validation

## Measurement systems and testing

- Measurements systems
- Sensor development
- Lidar development
- HW and SW
- Data management
- Turbine performance testing (loads, power, noise, electrical)
- Testing methods for turbines
- Calibration methods

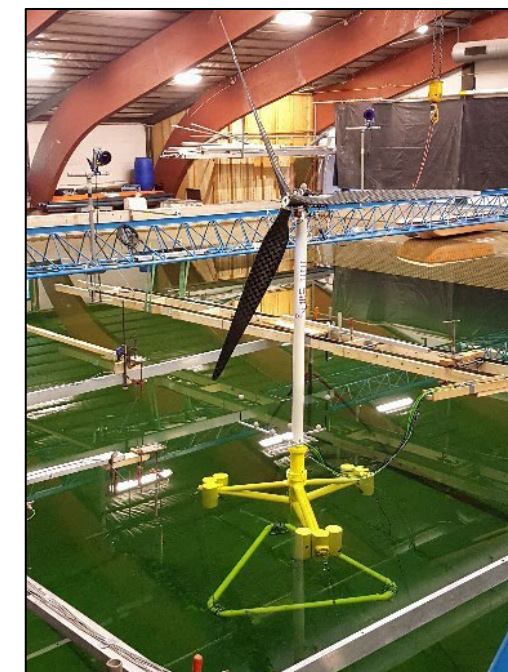
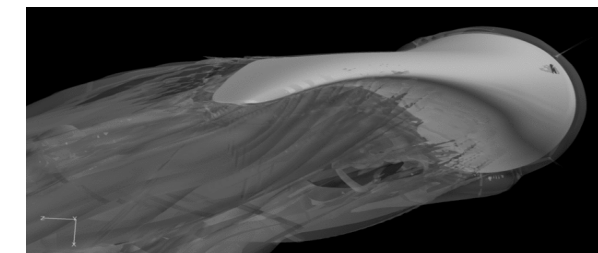
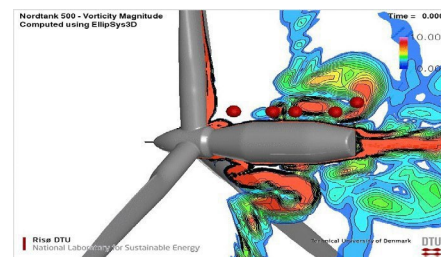
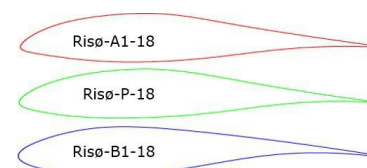

# Aerodynamic Design of Ground-effect Vehicle for Sustainable Transportation

- Ground-effect vehicles (GEV) offer a highly efficient solution for waterborne transportation over calm surfaces, such as a lakes. When combined with fully electric propulsion powered by batteries, GEVs represent a sustainable alternative to conventional boats.
- The student will:
  - Apply an existing lifting-line code for aerodynamic calculation and design.
  - Optimize wing planform and geometry for efficiency and stability.
  - Evaluate trade-offs in payload, range and cruise performance.

## Keywords

Ground-effect Vehicle  
Lifting-line method  
Sustainable transportation  
Wing design and optimization

## Recommended prerequisites:

Aerodynamic modeling  
Lifting-line method  
Optimization

## Contact & Information

Mac Gaunaa [macg@dtu.dk](mailto:macg@dtu.dk)

Ang Li [angl@dtu.dk](mailto:angl@dtu.dk)

Wind Turbine Division

Master thesis: X

Bachelor project: (X)



Source: Screenshot from zaojiemowu @ douyin

# Analysis of Turbulent Inflow using Lidar Measurements for Aerodynamic Noise Application

LIDARs are used to measure wind speed characteristics. Nowadays, they can be mounted on wind turbine nacelles, facing upstream in order to monitor the incoming flow field and associated turbulence. This set-up can be used for optimizing the turbine performance and reducing aerodynamic loads. These type of measurements focus on relatively large turbulence structures.

The aim of the project is to extrapolate the atmospheric turbulence characteristics to smaller structures. The latter are responsible for the generation of so-called turbulent inflow noise, which is an area of research to be further explored for modern large wind turbines. The results of this analysis can be used as input for noise modelling tools, and compared with noise measurements in the field.

This work will be a cooperation between DTU Wind, which has advanced tools for analysing LIDAR measurement data and predicting noise, and ENGIE (a french based energy producer) which has access to a large database of LIDAR (and noise) measurements.

## Keywords:

**Lidar measurements**

**Turbulence characterization**

**Noise prediction**

## Contact & Information

Contact person: F. Bertagnolio, A. Fischer, A. Peña

Mail: [frba@dtu.dk](mailto:frba@dtu.dk) / [asfi@dtu.dk](mailto:asfi@dtu.dk) / [aldi@dtu.dk](mailto:aldi@dtu.dk)

Division: Wind Turbine Design / ENGIE

Master thesis: X

# Analysis of Wind Turbine Noise in Non-Nominal Conditions

The length of modern multi-MW wind turbine blades is of the order of 100 m (and above). During rotation their tips, where most of the aerodynamic noise is generated, can experience different wind conditions due to wind shear and/or other different atmospheric inflow conditions. In addition, due to the unsteady nature of atmospheric wind, these conditions do evolve over time. This has a significant impact on their noise emission and its assessment. However, prediction models often neglect these spatial and temporal inhomogeneities to some degree, or their qualitative impact is not well understood.

The aim of the project is to use a wind turbine rotor noise model and investigate the influence of relevant atmospheric flow parameters on a modern large wind turbine noise emission. The outcome would be a detailed overview of the critical parameters at stake, and how they affect the predicted noise, as well as its measurement in the field following standards.

## Keywords:

Wind turbine aerodynamics  
Turbulent inflow noise  
Trailing edge noise  
Noise predictions

## Contact & Information

Contact person: F. Bertagnolio, A. Fischer  
Mail: [frba@dtu.dk](mailto:frba@dtu.dk) / [asfi@dtu.dk](mailto:asfi@dtu.dk)  
Division: Wind Turbine Design / (possibly Vestas)  
Master thesis: X

# Atmospheric Flow Characterization using Stochastic Reduced Order Model

## Project Proposal:

Atmospheric turbulence is highly complex, and atmospheric flows are governed by a range of different drivers such as temperature differences, roughness, geostrophic wind speeds etc. The atmospheric flows greatly impact the loads and performance of wind turbines, and are typically characterized by statistics such as turbulence intensity (TI), shear, veer, wind speed etc. A data-driven reduced order model has been developed based on Large-Eddy Simulations (LES), which enable the generation of stochastic realizations at a fraction of the computational cost.

The aim of this project is to understand the complex flow and quantify statistical changes during different diurnal cycles, including different stochastic realizations.

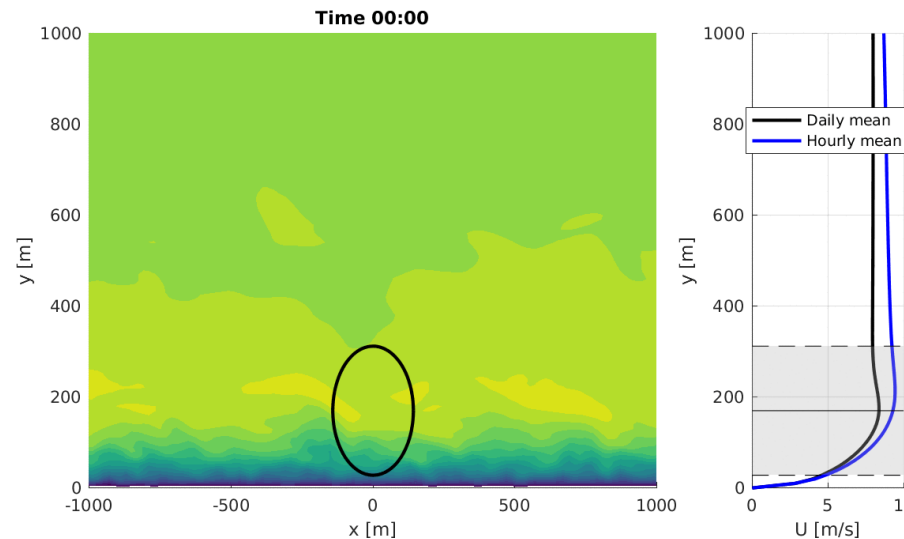

## Keywords:

- Computational fluid dynamics
- Atmospheric turbulence
- Stochastic Modelling
- Data-driven/Machine-Learning

## Contact & Information

Contact person: Søren Andersen

Mail: [sjan@dtu.dk](mailto:sjan@dtu.dk)

Division: Wind Turbine Design

Master thesis: X

Bachelor project: X

Can be both: X

# Beyond superposition: advancing near-wake vortex-cylinder (NW-VC) model for curved blades

- We have recently developed a coupled near-wake vortex cylinder (NW-VC) model for aerodynamic modeling of curved blades, including sweep, prebend, coning and deflection. In the current framework, the blade sweep and prebend effects are model separately and then superimposed. While this approximation is supported by CFD evidence, further improvements are valuable. This model has already been applied successfully in rotor design optimization studies.
- The student will:
  - Investigate and implement possible near wake model enhancements.
  - Evaluate the impacts at different operational conditions.
  - Benchmark against existing CFD results.
  - Apply the improved model to rotor optimization studies.

## Keywords

Aerodynamic modeling  
Curved blade aerodynamics  
Rotor design

## Recommended prerequisites:

Aerodynamic modeling  
BEM method  
Lifting-line method

## Contact & Information

Ang Li [angl@dtu.dk](mailto:angl@dtu.dk)  
Wind Turbine Design  
Master thesis: X

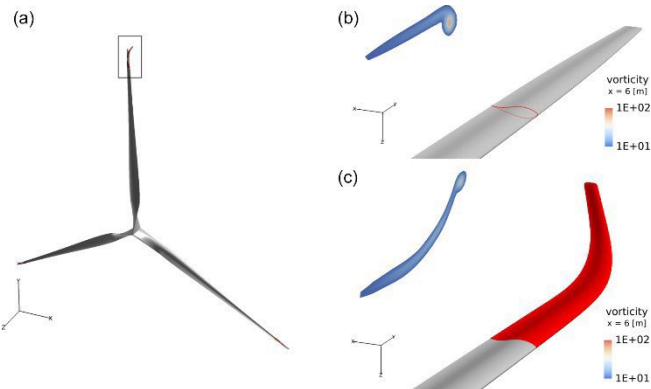

Source: Mads Madsen et al.



Source: eocycle M-21



Source: Gang Wang

# Blade Load Estimation using Sensors on Tower

Individual pitch control (IPC) is a proven blade pitch control method for mitigating unbalanced rotor loads, which are typically caused by wind shear and gravitational loading. The approach allows each blade to be pitched individually in response to its specific loading. Despite its effectiveness, IPC has not yet been widely deployed. One of the main barriers is the need for additional strain gauges at the blade roots.

This project investigates the feasibility of estimating blade loads from tower sensors instead. Tower-top strain gauges are easier to access for installation and maintenance, and their application requires less specialised expertise compared to attaching strain gauges to composite blade roots. The proposed method involves control-oriented modelling of the turbine tower and blade structures. A state observer/Kalman filter technique will potentially be employed to estimate blade loads and determine the optimal placement of tower sensors. The estimated blade loads will then be validated in IPC simulations in HAWC2.

## Keywords

Estimation

Control

Modelling

## Contact & Information

**Contact person:** Alan Wai Hou Lio,  
Sangwon Lee, Taeseong Kim

**Mail:** [wali@dtu.dk](mailto:wali@dtu.dk), [sanle@dtu.dk](mailto:sanle@dtu.dk),  
[tkim@dtu.dk](mailto:tkim@dtu.dk)

**Division/Company:** Wind Turbine Design

Master thesis: X

Bachelor project: X

Can be both: X

## Project Proposal:

Trackman develops advanced golf simulators, which enables golf players to play golf virtually on many different international golf courses. The simulator includes detailed aerodynamics of the golf balls, but the representation of the atmospheric boundary layer (ABL) is simplified. The project can be separated into different parts. One component relates to performing steady state computational fluid dynamics (CFD) simulations of a golf course with varying degrees of complexity to understand the impact on flow. Another component is the development of a data-driven reduced order model (ROM) to provide fast and accurate ABL flow.

## Keywords:

- Computational fluid dynamics
- Atmospheric turbulence
- Data-driven/Machine-Learning

## Contact & Information

Contact person: Søren Andersen,  
Niels Trolborg

Mail: [sjan@dtu.dk](mailto:sjan@dtu.dk), [niet@dtu.dk](mailto:niet@dtu.dk)

Division: Wind Turbine Design  
Master thesis: X



# CFD reproduction of floating wind turbine response to nonlinear waves

When near-breaking and breaking waves interact with floating wind turbine substructures, nonlinear response effects occur. They emerge both as high-frequency motion at the 2nd and 3rd harmonic frequency ranges of the spectrum and as low-frequency response due to sub-harmonic wave forcing.

We have conducted a series of tests in 2025 both with focused wave groups and long time series, well suited for reproduction in OpenFOAM. In the project we will make use of *harmonic decomposition*, where several phase shifted tests are combined to extract the nonlinear response. We will make the same computations in OpenFOAM and thereby be able to compare the isolated nonlinear motions from experiment and CFD.

If you are passionate about nonlinear hydrodynamics and CFD, this is the project for you!

## Contact & Information

Contact person: Sithik Aliyar, Henrik Bredmose

Mail: [sitali@dtu.dk](mailto:sitali@dtu.dk) [hbre@dtu.dk](mailto:hbre@dtu.dk)

Division: Wind Turbine Design

Master thesis: X

## Keywords:

- Floating wind
- Hydrodynamics
- Waves
- OpenFOAM
- Extreme conditions

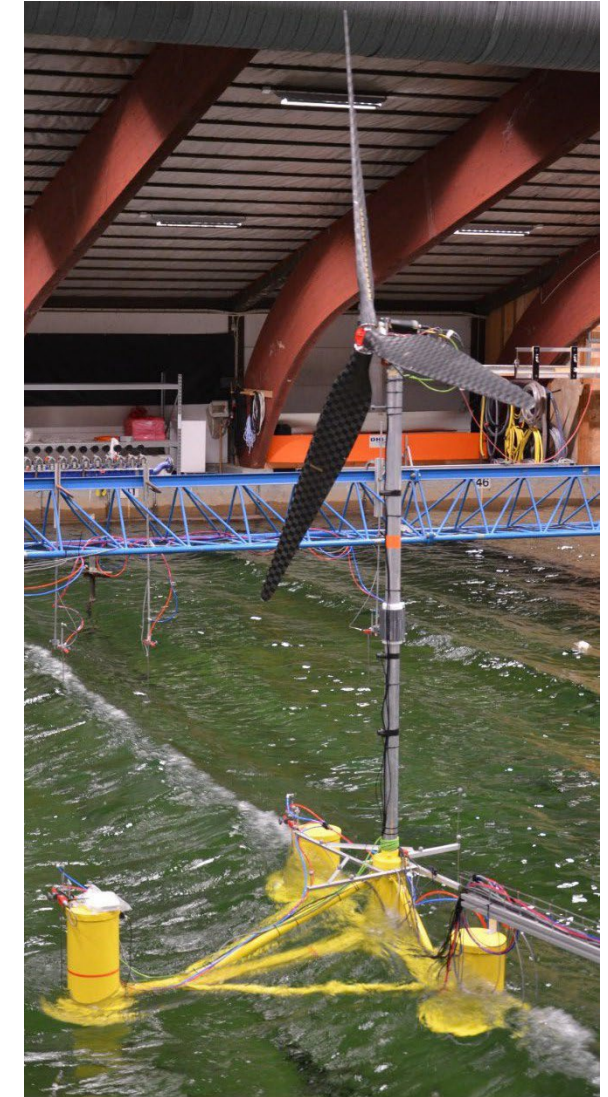

## Project Proposal:

Wind turbine wakes lead to power losses in wind farms, and therefore developing techniques to improve wake recovery is very important. Operating turbines at a high tip speed ratio but the same thrust coefficient may lead to faster breakdown of the tip vortices in the near wake, and hence improved wake recovery. This project will investigate the wake recovery behind turbines with different tip speed ratios by analysing data from Large Eddy Simulations (LES). Wake recovery, wake dynamics and downstream turbine power output can be analysed, as well as comparing different inflows and turbine modelling methods.

## Keywords:

- Computational fluid dynamics
- Wind turbine wakes
- Wind turbine modelling
- Turbulence

Faster near wake  
breakdown

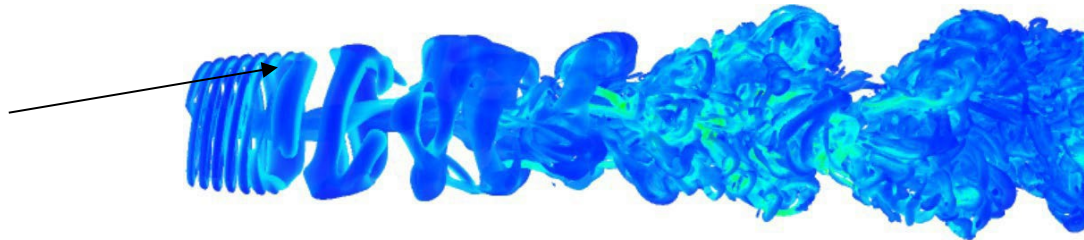

Slower near wake  
breakdown

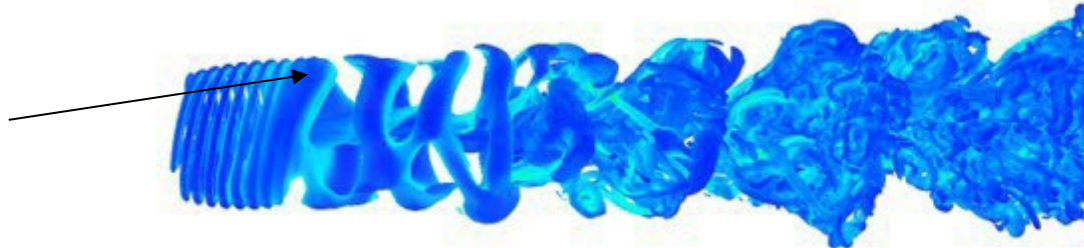

## Contact & Information

Contact person: Emily Hodgson

Mail: [emlh@dtu.dk](mailto:emlh@dtu.dk)

Division: Wind Turbine design

Master thesis: X

## Project Proposal:

Wake steering through yaw misalignment is a method with potential to improve wind farm power output by mitigating wake effects. However, the predicted power gains are highly sensitive to uncertainty in the inflow wind direction, which is introduced through imperfect measurements and is inherent in the atmosphere. This project will assess the impact of wind direction uncertainty on power changes due to wake steering, specifically in relation to the asymmetry between positive and negative yaw directions, by analysing data from Large Eddy Simulations (LES). Mean wake flow, wake dynamics, power output, turbine loads can be investigated. Surrogate modelling can also be performed.

## Keywords:

- Computation fluid dynamics
- Wind turbine wakes
- Wind farm flow control
- Uncertainty quantification
- Surrogate modelling

Mean flow  
for different  
wind  
directions

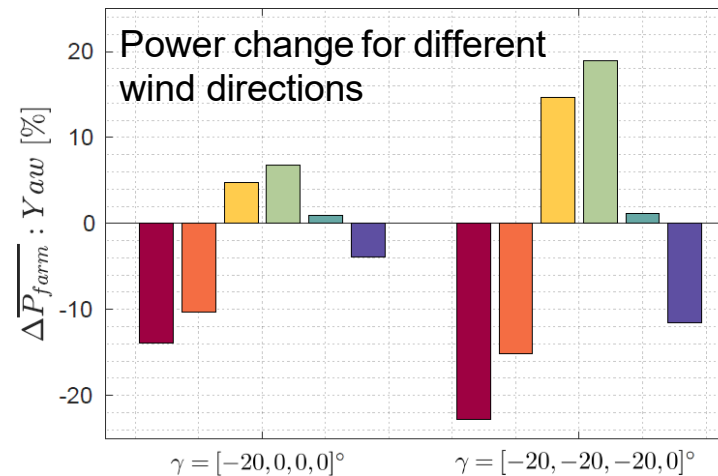
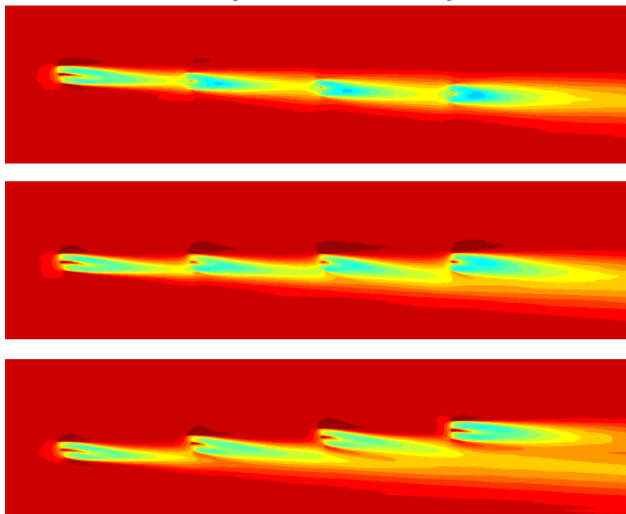

## Contact & Information

Contact person: Emily Hodgson

Mail: [emlh@dtu.dk](mailto:emlh@dtu.dk)

Division: Wind Turbine design

Master thesis: X

Bachelor project: X

Can be both: X

We are inviting motivated master's students to participate in a project on CFD-based multibody simulations of floating offshore vessels, with a focus on Operations & Maintenance (O&M) of offshore wind platforms. The project aims to validate high-fidelity numerical models against experimental data, using results from DHI's floating vessel experiments that capture realistic vessel motions and hydrodynamic interactions. These experiments provide a unique benchmark for assessing CFD predictions under conditions relevant to O&M operations, such as maintenance, installation, and crew transfer.

Student will gain hands-on experience in multibody dynamics, hydrodynamic simulations, and experimental validation, learning how computational tools can predict vessel behavior during realistic operational scenarios. The project offers exposure to state-of-the-art CFD software, floating system modeling, and practical O&M challenges in offshore renewable energy.

Ideal candidates have a background in mechanical, naval, or ocean engineering, fluid mechanics, or applied mathematics, and are eager to connect theory with real-world offshore operations.

## Keywords:

- CFD (Computational Fluid Dynamics)
- Multibody dynamics
- Floating offshore vessels
- Offshore wind platforms
- Operations & Maintenance (O&M)

## Contact & Information

Contact person: Sithik Aliyar & Henrik Bredmose

Mail: [sitali@dtu.dk](mailto:sitali@dtu.dk)

Division: Wind Turbine Design

Master thesis: X

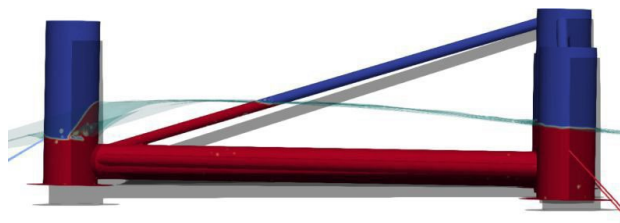
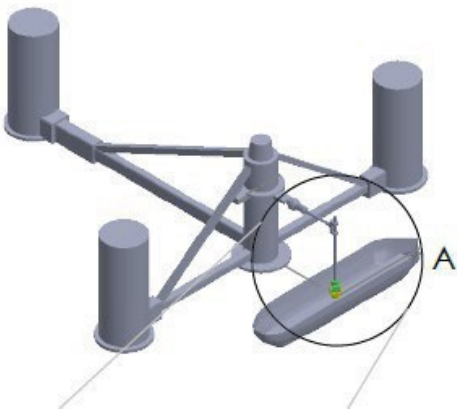

## Project Proposal:

Engineering wake models are simple, fast tools to model wind turbine wakes and wind farm flows, but are heavily reliant on tuning constants and the superposition method used to combine individual wakes. This project will assess the ability of engineering wake models to represent partial wake flows by running simulations with PyWake and comparing with Large Eddy Simulation (LES) data of a row of turbines with different wind directions, in terms of wake predictions and wind farm power output. Different wake and superposition models can be evaluated, and wake steering through yaw misalignment could also be investigated.

## Keywords:

- Computational fluid dynamics
- Engineering wake models
- Wind farm flows
- Model comparison

## Comparison of different engineering models:

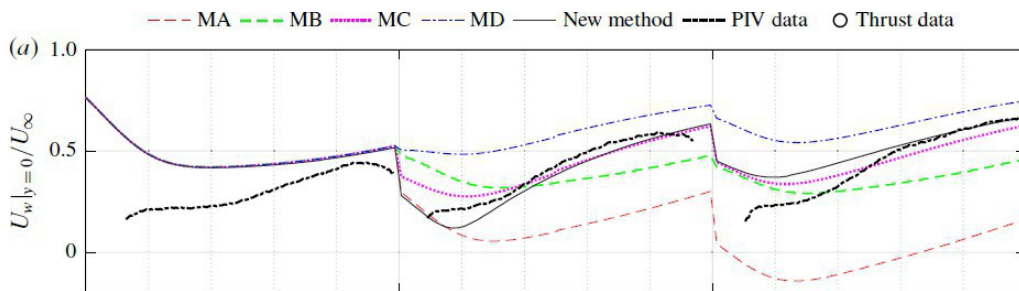

From: Zong and Porte-Agel, 2020

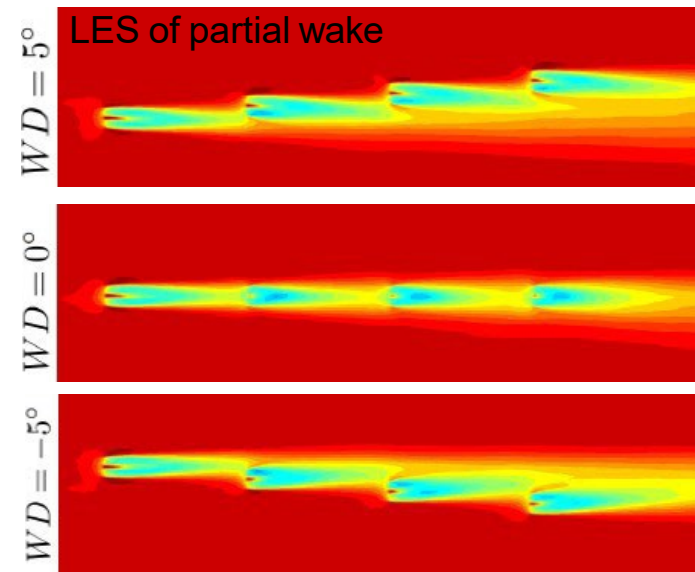

## Contact & Information

Contact person: Emily Hodgson

Mail: [emlh@dtu.dk](mailto:emlh@dtu.dk)

Division: Wind Turbine design

Master thesis: X

# Consistency in Mean Velocity Estimates between Different CFD fidelities

## Project Proposal:

Computational Fluid Dynamics (CFD) is used to solve the wake flows around wind turbines and within larger wind farms. Different CFD models and fidelities exist, where the governing equations are simplified for the computations. For instance, Reynolds Averaged Navier-Stokes (RANS) yields time-averaged results, while Large Eddy Simulations (LES) gives dynamic results, which are filtered spatially. The different fidelities and approaches give rise to different results, even in time-averaged mean velocities as shown in the figure where LES is compared against the RANS model by van der Laan.

The aim of this project is to compare and quantify the mean velocity estimates from RANS and LES and potentially simpler models to develop an "error estimator", which can be used to correct low or medium fidelity results to accurately capture higher fidelity results from LES using machine-learning methods.

## Keywords:

- Computational Fluid Dynamics (CFD)
- RANS + LES
- Wind turbine wakes
- Machine-learning/surrogate

## Contact & Information

Contact person: Søren Andersen, Paul van der Laan

Mail: [sjan@dtu.dk](mailto:sjan@dtu.dk), [plaa@dtu.dk](mailto:plaa@dtu.dk)

Division: Wind Turbine Design

Master thesis: X

Bachelor project: X

Can be both: X

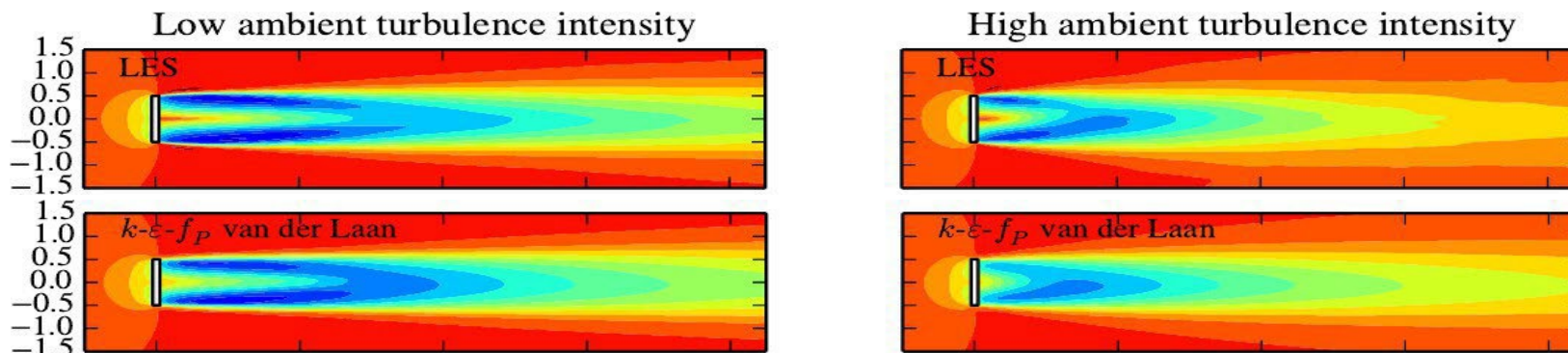

## Description:

This project aims to develop and validate a coupled simulation framework that integrates **HAWC2** (a high-fidelity aeroelastic code) with **OpenFOAM** (a CFD-based hydrodynamic solver) to accurately capture the complex fluid-structure interactions of **floating offshore wind turbines (FOWTs)** under realistic sea conditions. Inspired by the recent study *“High-fidelity simulations of a floating offshore wind turbine in irregular waves by coupling OpenFOAM and OpenFAST”*, the project will extend these ideas to the HAWC2 environment, enabling advanced aero-hydro-servo-elastic simulations. The student will implement the data exchange interface between the two solvers, perform dynamic simulations in irregular waves, and analyze the resulting loads, motions, and performance metrics. The work contributes to the ongoing efforts toward **digital twins and high-fidelity validation of floating wind systems**.

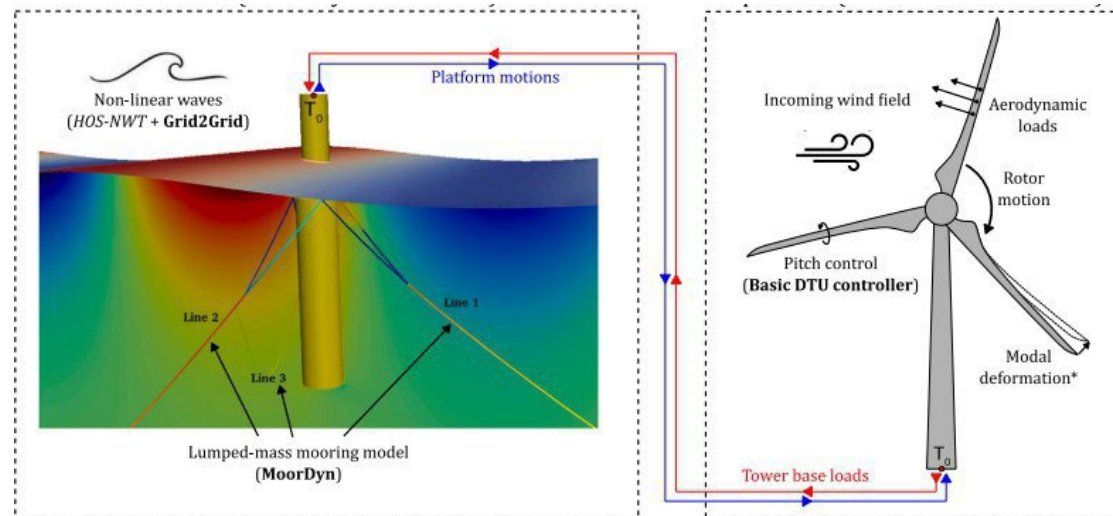

## Keywords:

- Floating Offshore Wind Turbines
- HAWC2
- OpenFOAM
- Aero-hydro-servo-elastic coupling
- CFD, High-fidelity simulations

## Contact & Information

Contact person: Sithik Aliyar & Henrik Bredmose

Mail: [sitali@dtu.dk](mailto:sitali@dtu.dk)

Division: Wind Turbine Design

Master thesis: X

# Design and analysis of a hydrofoil setup for a small leisure motor-boat or a solar challenge race boat

The hydrodynamic efficiency of planing boats is limited due to the physics at play. This results in excessively high power requirements, fuel costs and CO<sub>2</sub> generation. This render electric solutions unrealistic due to battery weight and price. Lifting the hull out of the water using a hydrofoil setup offer the possibility of drastically improved efficiency (~80%), bringing electric solutions within reach.

The present project builds on previous MSc works and use mostly the same tools and methods used in aerodynamics and stability analysis for wind energy. The study will use an already existing lifting-line based simulation method for calculation of the hydrodynamic forces.

The two overall paths this MSc thesis work can take is (1) to work with design and analysis of a smaller motorboat for possible future testing, or (2) to analyze and suggest improvements for the hydrofoil setup for DTU's existing monaco energy boat challenge vessel.

The specific tasks to be carried out could be:

- Make/refine a design tool for hydrofoil system/setup design
- Make a sailing situation analysis/prediction tool
- Make a full dynamic stability assessment tool



## Contact & Information

Name: Mac Gaunaa, Robert Mikkelsen

Mail: [macg@dtu.dk](mailto:macg@dtu.dk) [rfmi@dtu.dk](mailto:rfmi@dtu.dk)

Division: Wind Turbine Division

Master thesis: X

Bachelor project: (X)

# Design and wind tunnel test of porous disc for emulated rotor thrust

Rotor aerodynamic thrust generated by the spinning blades may in some experimental setup be replaced by a porous disc capable of producing an equivalent drag force as a real rotor thrust. For certain experimental setups it is advantageous not to have spinning blades but maintain the loading using a simple drag device, wake studies, floating turbine, etc.

The project undertaken suggest to investigate researched [1] disc geometries using CFD and wind tunnel modeling and extend disc-designs to cover a larger part of the thrust curve than just a single point.

The present project is focused on

- Wind tunnel testing of porous disc
- CFD analysis of porous disc
  - Actuator disc modeling
  - Resolved geometry
- Design a variable thrust porous disc

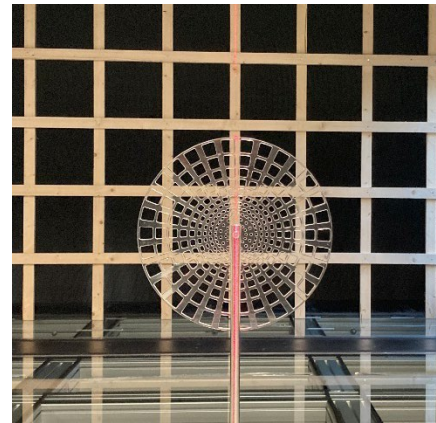

[1] Round-Robin test II – wake measurements of porous discs under clearly defined boundary conditions. M. Hölling et al. WEC 2025

## Keywords:

Rotor aerodynamic thrust, porous disc, Wind Tunnel testing

## Contact & Information

Contact person: Robert Mikkelsen,

Jens H. Walter, Fabio Pierella

Mail: [rfmi@dtu.dk](mailto:rfmi@dtu.dk)

Division: Wind Turbine Design

Master thesis: X

Bachelor project: X

Can be both: X

The Magnus rotor has been the main choice for Wind Assisted Ship Propulsion, WASP, in recent years.

The project undertaken suggest to design a magnus rotor for wind tunnel test but also perform CFD on the setup.

The present project is focused on

- Design of a Magnus rotor - surface tabs possibilities should be addressed
- CFD analysis
- Wind tunnel testing of Magnus rotor
- Smooth vs rough

Keywords:

Magnus force, CFD, Wind tunnel testing

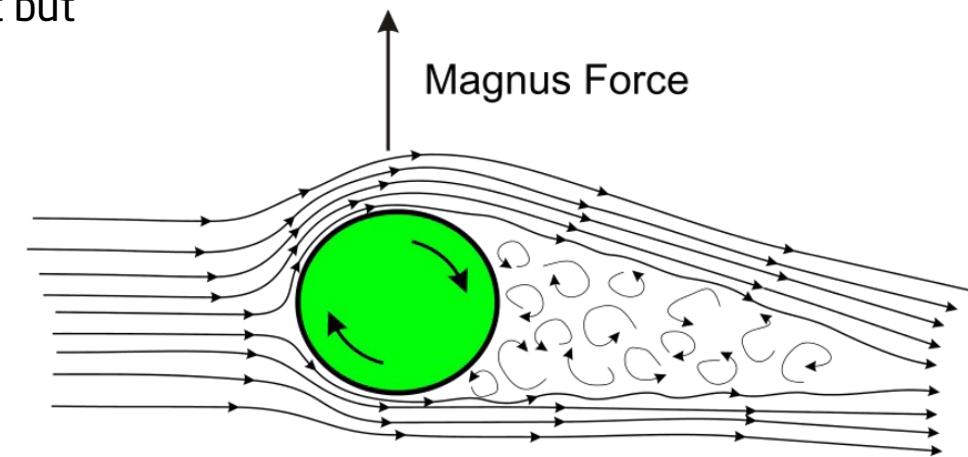

## Contact & Information

Contact person: Robert Mikkelsen,  
Mac Gaunaa

Mail: [rfmi@dtu.dk](mailto:rfmi@dtu.dk)

Division: Wind Turbine Design

Bachelor project: X

# Design of an Individual Pitch Controller for a model 22MW floating wind turbine

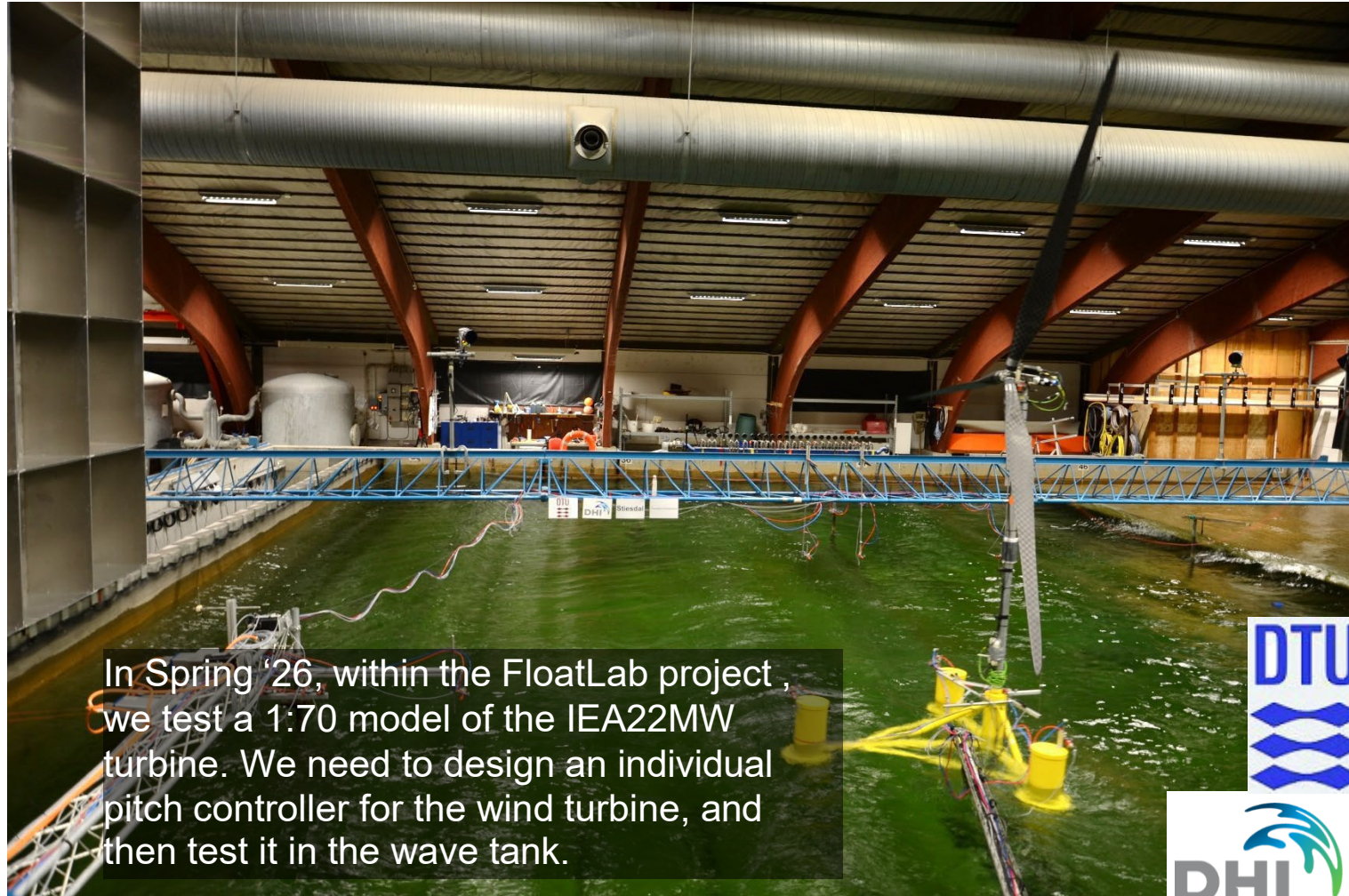

In Spring '26, within the FloatLab project, we test a 1:70 model of the IEA22MW turbine. We need to design an individual pitch controller for the wind turbine, and then test it in the wave tank.

**Keywords:** wave tank, experiments, IEA22MW, controller, HAWC2, PID, simulations, FloatLab

**Skills:** HAWC2, Course 46320 Loads, Aerodynamics and Control of Wind Turbines

## Contact & Information

Contact person: Fabio Pierella

Mail: [fabpi@dtu.dk](mailto:fabpi@dtu.dk)

Division: Wind Turbine Design

Master thesis: X

# Development and verification of control strategies for wind turbine loads reduction

As wind turbines continue to increase in size to harvest more energy, they are subjected to stronger and more uneven wind loads. These loads lead to increased fatigue and, therefore, greater maintenance demands, ultimately affecting the reliability and cost of wind energy production.

This thesis addresses these challenges by improving and verifying the advanced control strategies implemented in the DTU Wind Energy Controller (DTUWEC) for wind turbine load reduction. In this thesis, control strategies such as individual pitch control, drive-train damper, and tower damper, etc., need to be further improved and tested using HAWC2 simulations to analyze their effectiveness under realistic operating conditions.

The results provide valuable insights into how active control can enhance turbine performance, reduce operational costs, and support the continued growth of wind energy.

## Keywords

Individual pitch control;  
Drive train damper;  
Loads reduction;

## Contact & Information

Contact person:

Fanzhong Meng, Andrew Russell,  
Mail: [famen@dtu.dk](mailto:famen@dtu.dk) [ajaru@dtu.dk](mailto:ajaru@dtu.dk)

Division: Wind Turbine Design

Master thesis: X

Recent experimental work in the national Danish Poul LaCour wind tunnel <https://www.plct.dk/> and in DTU's red wind tunnel have focused on unsteady airfoil aerodynamics and dynamic stall.

Dynamic stall is a non-linear unsteady aerodynamic effect that occurs when airfoils undergo unsteady motion. The effect of dynamic stall is important both for conventional HAWTs and especially for VAWTs, where the AOA amplitudes are very large.

The present project is focused on

- Wind tunnel testing of a low-Re airfoil
- Investigate lag effect from pressure tubes, phase and amplitude
- Work with high-Re unsteady airfoil data from PLCT
- Apply corrections, unsteady wind tunnel blockage, lags, etc.
- Simplified numerical modelling of dynamic stall

Programming skills is required (Matlab)

## Keywords:

Aerodynamic Experiments,  
Unsteady Aerodynamics, Dynamic  
Stall, Pressure Lag,  
Wind Tunnel Corrections

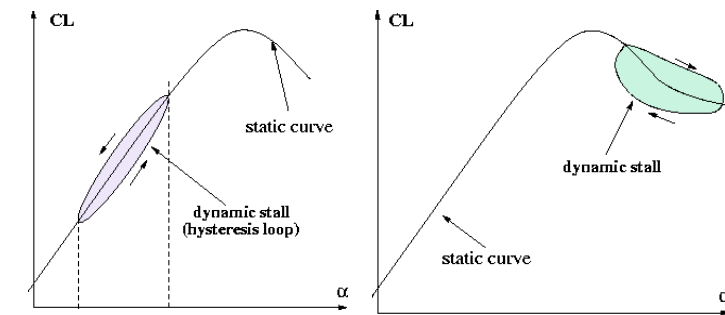

From <https://aerodyn.org/>

## Contact:

Name: Robert Mikkelsen, Mac  
Gaunaa, Andreas Fischer  
Mail: [rfmi@dtu.dk](mailto:rfmi@dtu.dk)  
Division: Wind Turbine Design  
Master thesis: X

# Efficient aerodynamic modeling of curved blades for rotor design and aeroelastic simulation

- Accurate modeling of wind turbine aerodynamics considering the blade prebend, curvature and deformation is essential. A recently developed coupled near- and far-wake model enables efficient simulations of curved blades, but the frequent need for updating the far-wake vortex cylinders (computational heavy) limits its application in time-domain aeroelastic tools, such as DTU's HAWC2.
- The student will:
  - Investigate and develop new coupling strategies.
  - Explore approximations and reformulations of the far-wake model.
  - Benchmark efficiency of alternative coupling methods.
  - Compare against existing CFD results.
  - Apply the improved model to rotor optimization studies.

## Keywords

Aerodynamic modeling  
Curved blade aerodynamics  
Rotor design

## Recommended prerequisites:

Aerodynamic modeling  
BEM method  
Lifting-line method

## Contact & Information

Ang Li [angl@dtu.dk](mailto:angl@dtu.dk)  
Wind Turbine Design  
Master thesis: X

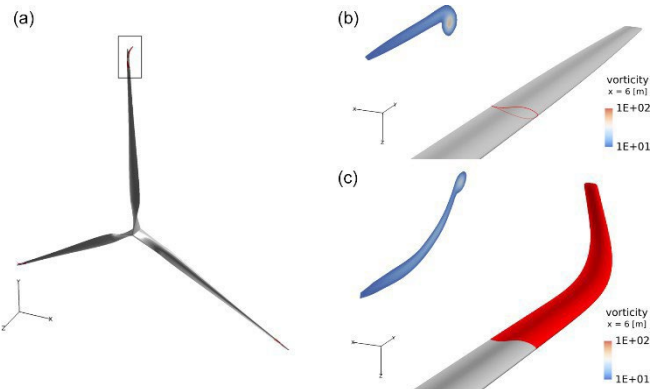

Source: Mads Madsen et al.



Source: eocycle M-21



Source: Gang Wang

# Experimental measuring and identification of slamming loads in a Floating Wind Platform

Understanding platform loads in floating wind turbines is essential to safely reduce the cost of this promising technology. Among these loads, slamming events are particularly challenging since they are highly non-linear, difficult to predict and hard to measure.

To tackle this problem, an experimental campaign will be carried out during the spring of 2026, focused on identifying and evaluating slamming loads. The campaign will feature a fully functional floating wind platform subjected combined wind and wave conditions. Slamming events will be captured using accelerometers, force transducers, and pressure sensors.

The tests will take place at the Danish Hydraulic Institute (DHI). This is a unique opportunity for students who are passionate about hydrodynamics and eager to get hands-on experience in experimental research. If you are interested or would like to know more, send us an email.

## Contact & Information

Contact person:

Ignacio Johannesen, Henrik Bredmose

Mail: [iapjo@dtu.dk](mailto:iapjo@dtu.dk) [hbre@dtu.dk](mailto:hbre@dtu.dk)

Division: Wind Turbine Design

Master thesis: X

## Keywords:

- Floating wind
- Hydrodynamics
- Waves
- Slamming loads
- Extreme conditions
- Experimental campaign
- Hands on

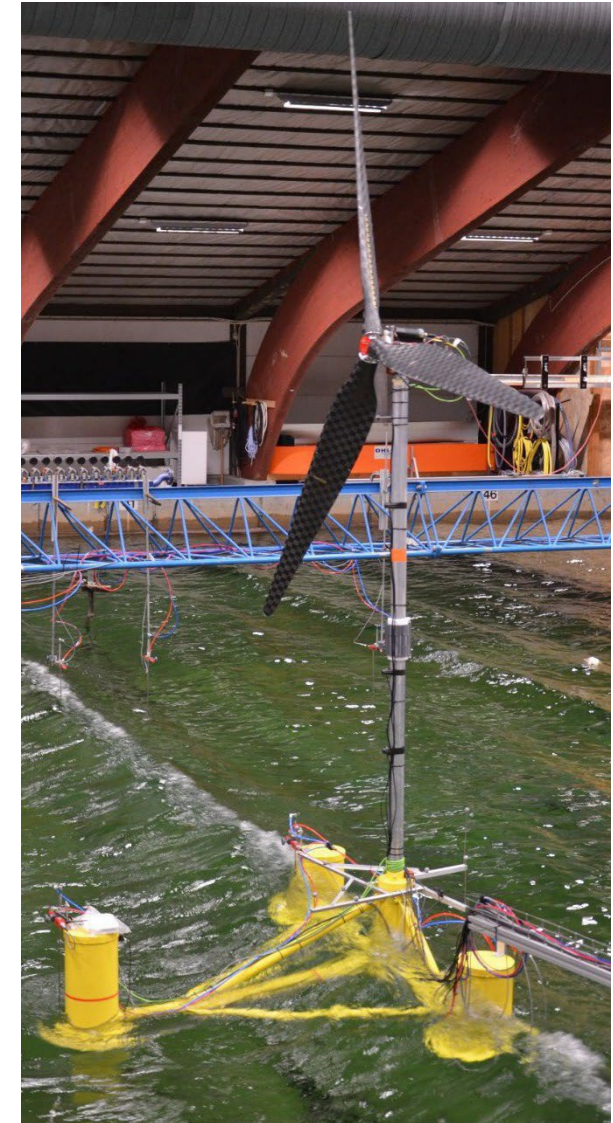

# HAWC2-MIRAS re-simulation of floating wind turbine tests

The aerodynamics of floating wind turbines is complex due to the motion of the rotor. This alters the wake recovery due to increased mixing. Also the wake is deflected upwards due to the steady rotor tilt. Unsteady effects are thus important as well as 3D flow effects along the blade.

We have conducted a series of tests in 2025 with a 1:70 scaled version of the IEA Wind 22 MW reference wind turbine in turbulent wind inflow. Some tests include waves and control. We have had a good reproduction of them in HAWC2 and have set up also the MIRAS free vortex solver and coupled it to HAWC2. In 2026 we'll make a new test campaign and are planning an MSc project to conduct HAWC2-MIRAS simulations of the new tests.

If you are passionate about floating wind and numerical aerodynamics, make contact to us.

## Contact & Information

Contact person:

Henrik Bredmose, Ang Li, Ignacio Johannesen

Mail: [hbre@dtu.dk](mailto:hbre@dtu.dk), [angl@dtu.dk](mailto:angl@dtu.dk), [iapjo@dtu.dk](mailto:iapjo@dtu.dk)

Division: Wind Turbine Design

Master thesis: X

## Keywords:

- Floating wind
- Aerodynamics
- Free vortex solver
- Experimental data

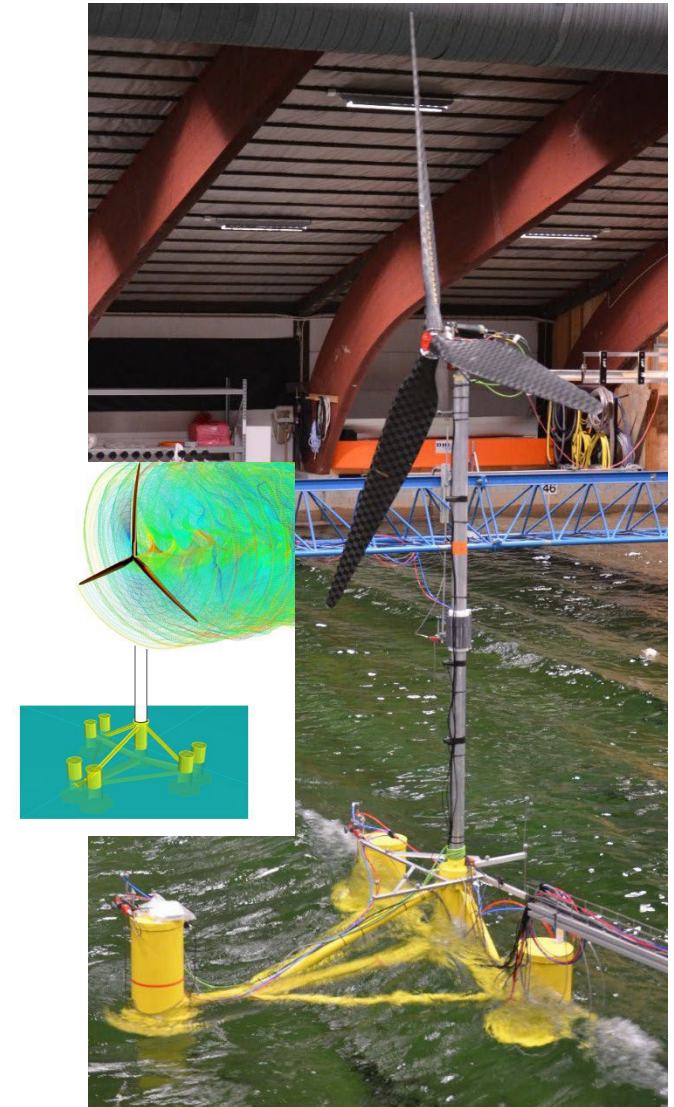

# Influence of flexibility on loads and wake of a 22MW turbine in CFD

## Project Proposal:

For very large wind turbines, including the effect of blade flexibility is becoming increasingly important in accurately modelling turbine loading, wakes and wind farm flow. The project will analyse data from large eddy simulations (LES) where turbines are simulated with and without flexibility to investigate the impact that aeroelastic modelling choices have on turbine loading and wake dynamics. Results from LES will be compared with standalone aeroelastic simulations in HAWC2 to study the influence of coupling LES to an aeroelastic solver. Comparison with a smaller turbine could also be performed.

## Keywords:

- Computational Fluid Dynamics
- Wind turbine modelling
- Blade flexibility
- Wind turbine wakes
- Aeroelastic load analysis

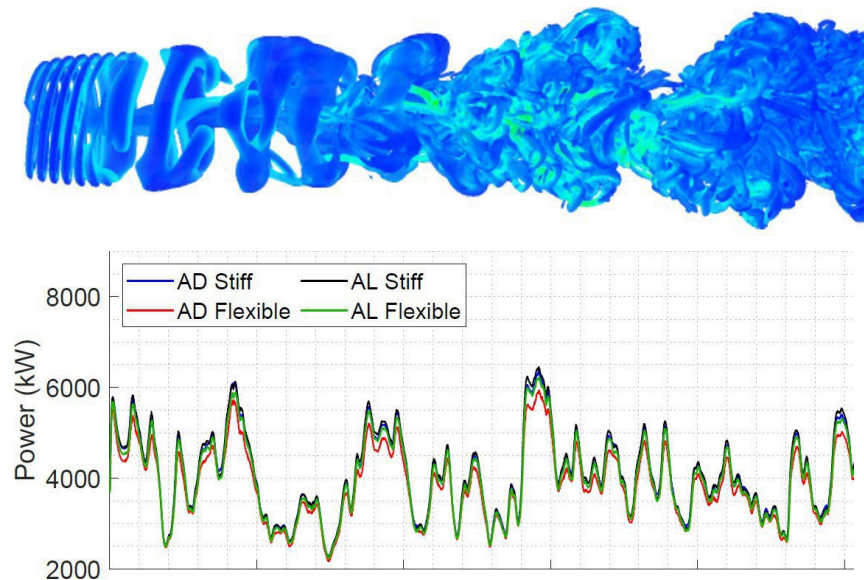
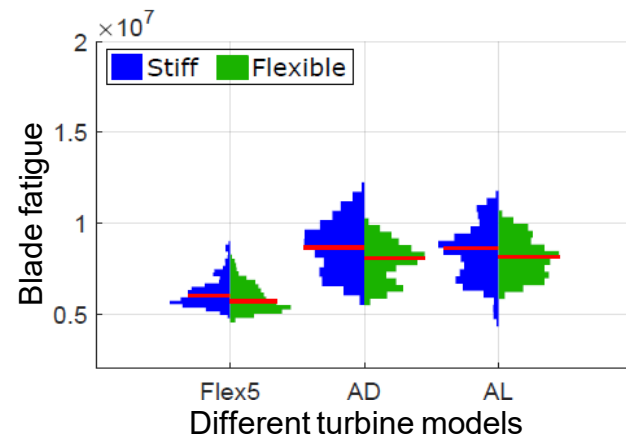

## Contact & Information

Contact person: Emily Hodgson

Mail: [emlh@dtu.dk](mailto:emlh@dtu.dk)

Division: Wind Turbine design

Master thesis: X

# Investigation of aerofoil noise directivity in the Red Wind Tunnel

The noise emission from wind turbines originated from the trailing edge, TE, emitted at the outer blade sections and is the dominant noise source on modern turbines. State-of-the-art engineering models for TE noise use simplified directivity models based on analytical solutions for flat plates. The engineering models on directivity and the interaction of boundary layer turbulence are the main tools combining flat plate solutions with empirical measurements. The newly rebuild Red Wind Tunnel for aero-acoustic measurements aims to improve engineering models through airfoil TE boundary layer and beam-forming measurements. In part, RWT needs to be characterized and compared with PLCT data.

The present project is focused on

- Aero-acoustic measurement in the Red Wind Tunnel, RWT, on the DU91-W2-250 airfoil
- Characterize RWT setup
- Comparison with [www.plct.dk](http://www.plct.dk) high Reynolds no. data
- Measurement of TE boundary layer - correlation with noise
- Uncertainty aspect in using simplifying assumption - flat plate vs curved foil

## Prerequisite:

Familiar with acoustic measurement and theory

## Keywords:

Aero-acoustics , Wind tunnel, airfoil noise

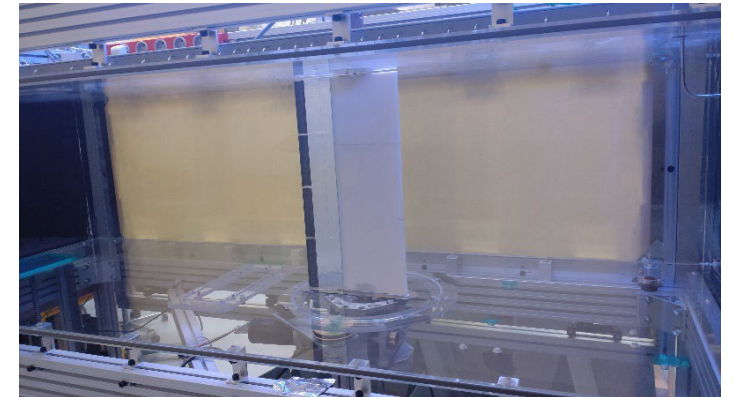

## Contact & Information

Contact person: Robert Mikkelsen,  
Andreas Fischer, Oliver Lyloff

Mail: [rfmi@dtu.dk](mailto:rfmi@dtu.dk)

Division: Wind Turbine Design

Master thesis: X

# Investigation of the roll-yaw couple motion by using individual pitch control on FOWT

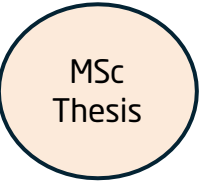

As floating wind technology rapidly advances, various concepts are being designed and tested, each with unique dynamics due to the movement of the floating platform. Among those motions, the floater roll motion, and the yaw motion are strongly coupled and has the potential to be unstable. Developing or improving a control strategy that considers this platform couple motion is essential to improving the system's stability and performance.

This thesis addresses the roll-yaw instability by improving the individual pitch control (IPC) strategy implemented in the DTU Wind Energy Controller (DTUWEC), And investigate the roll-yaw motion using HAWC2 simulations to analyze their effectiveness under realistic operating conditions.

The results provide valuable insights into how IPC can enhance the stability of the roll-yaw motion.

## Keywords

Individual pitch control;  
Floating offshore wind turbine;

## Contact & Information

Contact person:

Fanzhong Meng, Alan Wai Hou Lio

Mail: [famen@dtu.dk](mailto:famen@dtu.dk) [wali@dtu.dk](mailto:wali@dtu.dk)

Division: Wind Turbine Design

Master thesis: X

# Numerical investigations of the effect of flexibility on the loads of a floating wind turbine

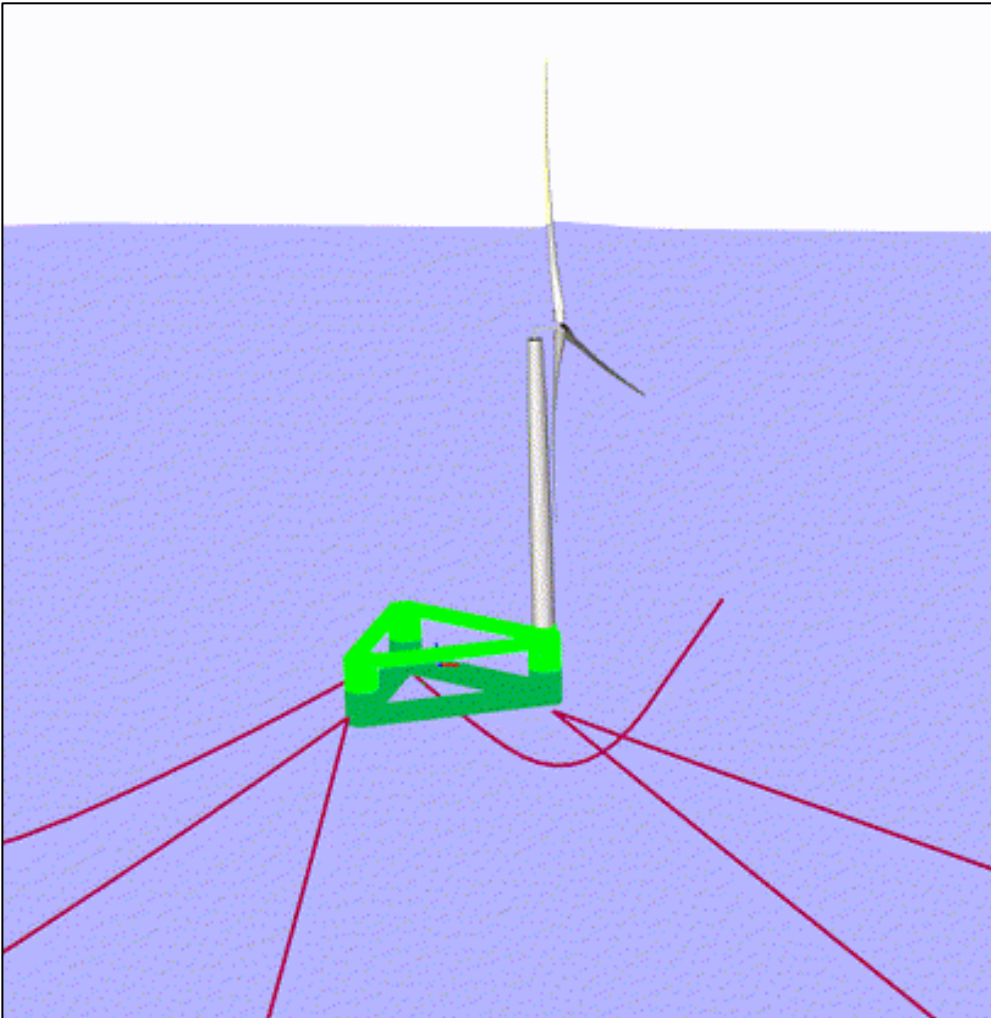

🌐 As turbines become larger, the substructures need to be lighter to reduce the costs.

🍂 Lighter structures are also more flexible, which could mean more complex vibrational modes and additional fatigue due to the dynamic loads.

🔧 In the OC7 research project, we investigate this through dedicated HAWC2 simulations.

🏠 Join in and help us achieve the goal!

**Keywords:** flexibility, floater modeling, finite element modeling, structural loads

**Skills:** HAWC2, Course 46320 Loads, Aerodynamics and Control of Wind Turbines, 46211 Offshore Course

## Contact & Information

Contact person: Fabio Pierella  
Mail: [fabpi@dtu.dk](mailto:fabpi@dtu.dk)  
Division. Wind Turbine Design  
Master thesis: X

# Oscillating inflow in airfoil testing using CFD and wind tunnels

Airfoil polars are most often tested in steady inflow through the AOA and Reynolds number range of interest, both aerodynamic and aero-acoustic testing. Airfoils in operation on wind turbine blades only operate in unsteady inflow conditions originating from atmospheric turbulence, wind shear and blade elastic response.

The project undertaken suggest to investigate application of unsteady inflow using cylindrical structures placed into the contraction of a wind tunnel. Large wake structure are then convected to the test-foil and impacts the AOA and airfoil boundary layer resulting in changed aerodynamic loading and aero-acoustic noise.

The present project is focused on

- Wind tunnel testing of unsteady inflow
- CFD analysis of wakes from a two-cylinder [1] configuration
- Airfoil testing with unsteady inflow - CFD and wind tunnel

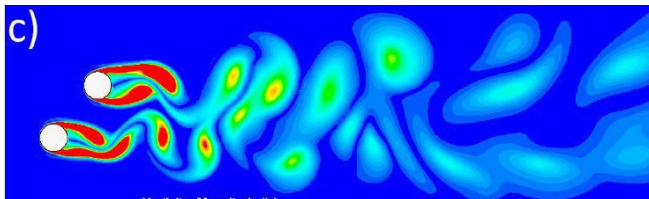

+

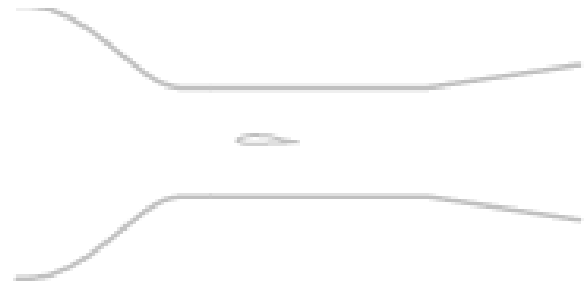

## Keywords:

Airfoil test, unsteady inflow, CFD  
Wind tunnel testing

## Contact & Information

Contact person: Robert Mikkelsen,  
Mac Gaunaa, Andreas Fischer  
Mail: [rfmi@dtu.dk](mailto:rfmi@dtu.dk)

Division: Wind Turbine Design

Master thesis: X

Bachelor project: X

Can be both: X

[1] Numerical Study of Flow around Two Circular Cylinders in Tandem, Side-By-Side and Staggered Arrangements. Gracjan M. Skonecki and James M. Buick

## Project Proposal:

In order to accurately predict wind farm flows and power output from CFD simulations, understanding the sensitivities and uncertainties of CFD is very important. This is particularly the case for wind farm flow control, which aims to deflect or reduce wake effects in wind farms in order to increase wind farm efficiency. The project will analyse data from Large Eddy Simulations (LES) of wind farms using wake steering and study power outputs, loading and/or wake dynamics. The influence of numerical choices, such as grid resolution and turbine modelling, can then be investigated.

## Keywords:

- Computational fluid dynamics
- Wind farm flow control
- Wind turbine wakes
- Uncertainty quantification

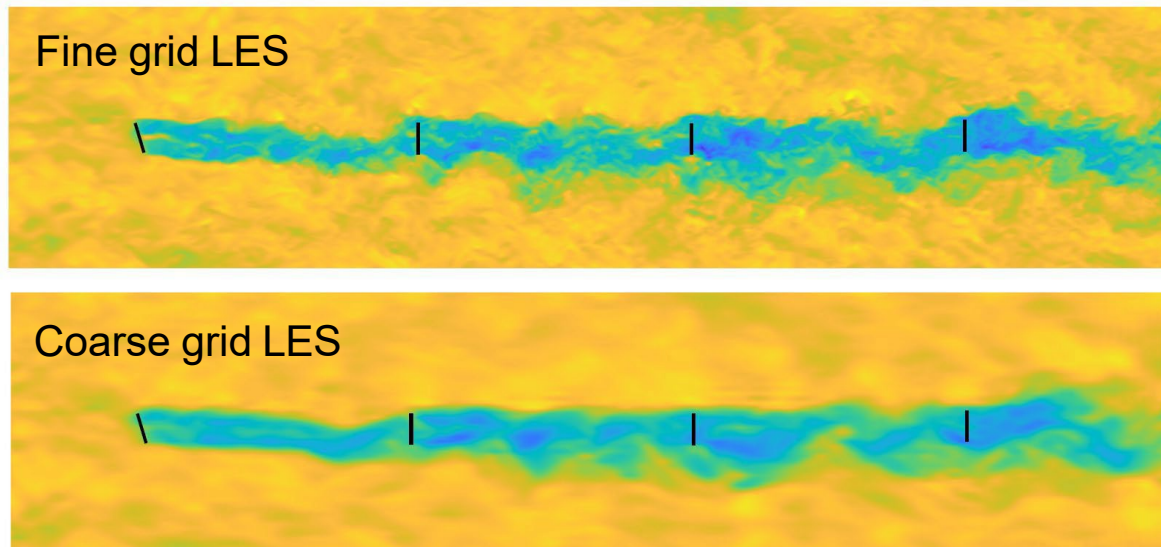

## Contact & Information

Contact person: Emily Hodgson

Mail: [emlh@dtu.dk](mailto:emlh@dtu.dk)

Division: Wind Turbine design

Master thesis: X

Bachelor project: X

Can be both: X

## THE CONTEXT

Wind turbine towers can experience *Vortex Induced Vibrations (VIV)*, compromising the structural integrity.

## LEARNING OBJECTIVES

Study of VIV for wind turbine towers by means of a Navier-Stokes solver, coupled with a 2D/3D structural model.

The student will improve her/his competences in aeroelasticity and Computational Fluid Dynamics (CFD) and Computational Structural Dynamics (CSD). This topic can be combined with experimental tests in the Red Wind Tunnel.

## SUGGESTED THESIS TOPICS

- Effect of Reynolds number and other parameters on tower VIV.
- Development of an efficient model for tower VIV prediction.
- CFD and wind tunnel experiments of VIVs

## Keywords:

Aeroelasticity

Towers

Computational Fluid Dynamics

Computational Structural  
Dynamics

Vortex Induced Vibrations

Wind tunnel experiments

**Contact person: Christian Grinderslev**

Email: [cgrinde@dtu.dk](mailto:cgrinde@dtu.dk)

Division: Wind Turbine Design

Master Thesis: X

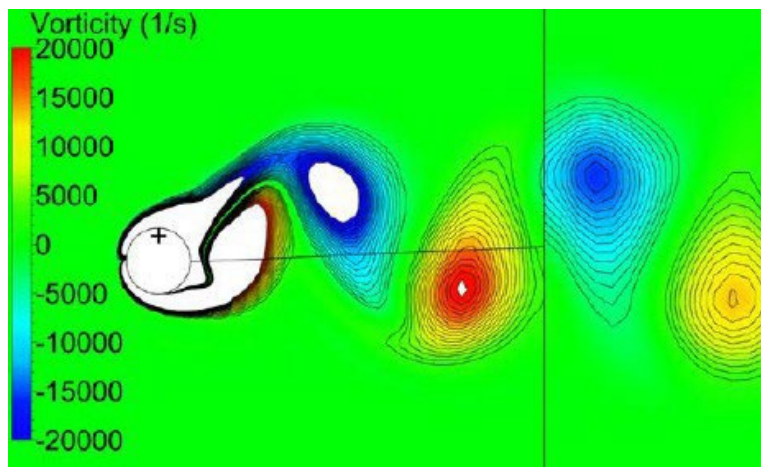

*Sergio González Horcas. CFD Methodology for Wind Turbines Fluid-Structure Interaction. Fluid Dynamics [physics.flu-dyn]. Université de Mons (UMONS), 2016. English. (tel-01562675)*

# Unsteady Actuator Line

## Description:

Actuator lines (AL) model wind turbine rotor forces efficiently in atmospheric flows & wind farms

Until now the AL force response is not validated for dynamic, unsteady inflow (turbulence, wakes etc)

## Aim:

Apply existing unsteady aerodynamic models with new correction to AL  
Implement and validate new model for rotors using our CFD solver

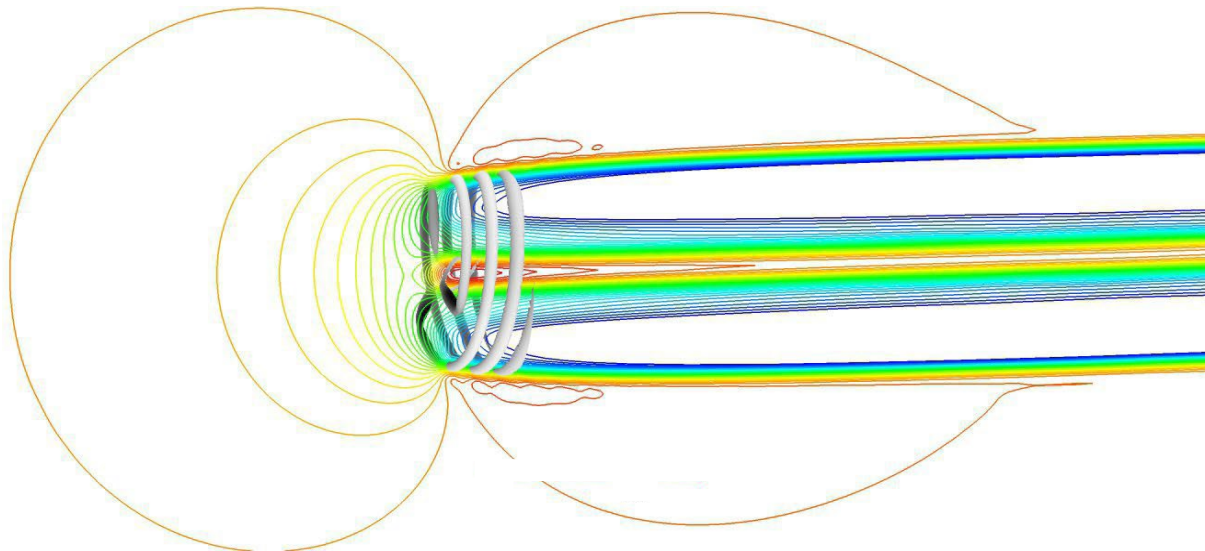

## Keywords:

CFD  
Actuator Line  
Shed Vorticity  
Dynamic Inflow  
Validation

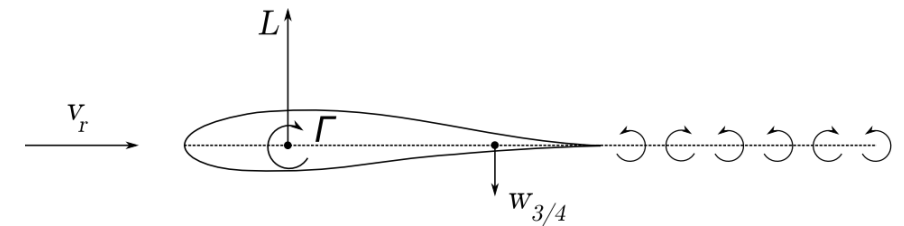

## Contact & Information

Name: Alex Meyer Forsting, Georg Pirrung,  
Mac Gaunaa  
Mail: [alrf@dtu.dk](mailto:alrf@dtu.dk), [gepir@dtu.dk](mailto:gepir@dtu.dk), [macg@dtu.dk](mailto:macg@dtu.dk)  
Division: Wind Turbine Division  
Master thesis: X  
Bachelor project: (X)

## THE CONTEXT

In standstill, wind turbine blades can experience *Vortex Induced Vibrations (VIV)*, compromising the structural integrity.

## LEARNING OBJECTIVES

Study VIVs on airfoils with Navier-Stokes solver, coupled with a structural model and/or using forced motion.

The student will improve her/his competences in aeroelasticity and Computational Fluid Dynamics (CFD).

## SUGGESTED THESIS TOPICS

- Parametric studies on the VIV phenomenon
- CFD and wind tunnel experiments of VIVs

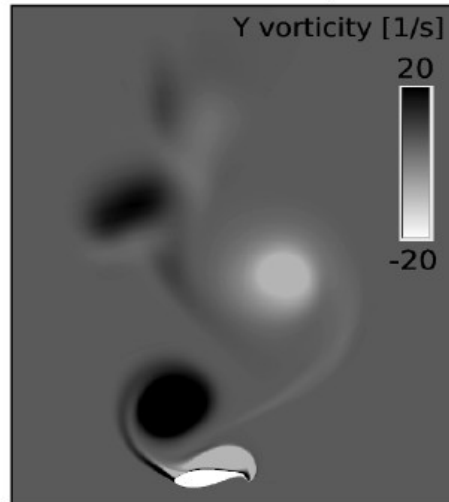
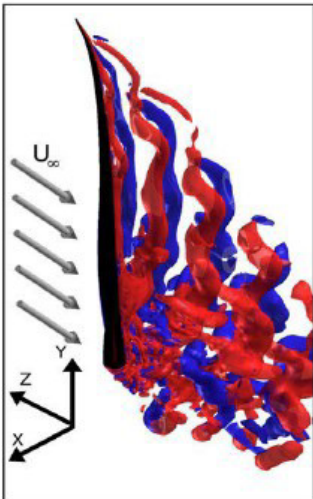

Horcas, S. G., Barlas, T., Zahle, F., & Sørensen, N. N. (2020). Vortex induced vibrations of wind turbine blades: influence of the tip geometry. *Physics of Fluids*, 32(6). <https://doi.org/10.1063/5.0004005>

Horcas, S. G., Madsen, M. H. A., Sørensen, N. N., & Zahle, F. (2019). Suppressing vortex induced vibrations of wind turbine blades with flaps. In E. Ferrer & A. Montlaur (Eds.), *Springer Tracts in Mechanical Engineering* (pp. 11–24). Springer.

## Keywords:

Aeroelasticity  
Blades  
Computational Fluid  
Dynamics  
Vortex Induced Vibrations  
Wind tunnel experiments

**Contact person: Christian Grinderslev**

Email: [cgrinde@dtu.dk](mailto:cgrinde@dtu.dk)

Division: Wind Turbine Design Master

Thesis: X

# Yawed Rotor Wake Modeling

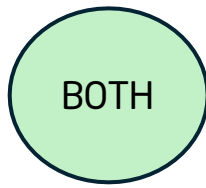

The wake behind a yawed wind turbine differs a lot from the one of similarly loaded unyawed turbine. The yawed case has a cross-flow motion of the wake and the shape of the wake distorts into a kidney-shape cross-sectional geometry. The shape, position and recovery of the wake behind a turbine is important for downstream turbines. Understanding/describing and modeling the key phenomena at play is of high importance.

This MSc project is envisioned to include investigations using a mix of an existing vortex-based engineering modeling framework and higher fidelity CFD actuator disc simulations, and may significantly aid the development of a new fast engineering model for the "fingerprint" of a yawed wind turbine.

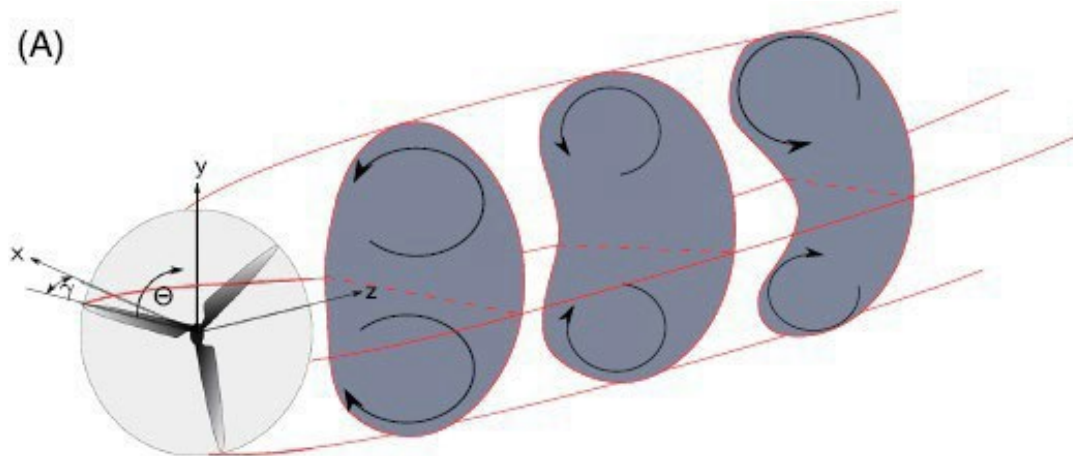

## Keywords:

Yawed Wind Turbine Wake  
Numerical Actuator Disc  
Modeling  
Vortex Cylinder modeling  
Engineering modeling

## Contact & Information

Name: Mac Gaunaa, Paul van der Laan  
Mail: [macg@dtu.dk](mailto:macg@dtu.dk) [plaa@dtu.dk](mailto:plaa@dtu.dk)  
Division: Wind Turbine Division  
Master thesis: X  
Bachelor project: (X)

# **Master thesis & Bachelor projects TOPICS From some of our industrial partners**

A grid company plans in collaboration with a local industrial company to install and connect a Battery Energy Storage (BESS) to the electricity distribution system. The BESS with capacity of 10 MW - 10 MWh shall be connected at medium voltage. The following must be investigated in the project initial phase:

- BESS concept and principles for battery charging and discharging.
- Building a static model in DlgSILENT PowerFactory (or ETAP) with the relevant data
- The PowerFactory model (or ETAP) is used for the following analyses:
  - Load flow analysis for both charging and discharging
  - Voltage variations in POC and main station for both charging and discharging
  - Short circuit analysis
- The project will describe theoretical principles for voltage stability in the power grid.
- The project will investigate the problem of voltage stability and draw a UP/Q diagram for Point of Connection (POC): UQ diagram and UP diagram.
- Is there a need for voltage regulation and reactive power compensation in POC? If so, what technical solutions are recommended?
- Does the current distribution network impose any limitations on charging and discharging BESS?
- Is there a need to strengthen the distribution network?
- Load model for industrial consumption? P; Q cos( phi ) or purely resistive load? Possibly power dependence  $P=f(?)$ ?
- Constant load for other consumption? P; Q cos( phi ) or purely resistive load?

Prerequisites for a weak MV network with long radials shall be clarified. The project will provide data for the electricity distribution network, including cable lengths, cable type and data, as well as MV/LV transformer data and system data for 60 kV feed-in . BESS data is supplied by the battery supplier for the selected BESS size with maximum battery capacity (10 MWh) and maximum power (10 MW).

## Keywords

- *Battery Energy Storage concept*
- *Power system modelling and simulation*
- *DlgSILENT PowerFactory*
- *Distribution grid properties*
- *Voltage stability in distribution grid*

## Contact & Information

Contact person: Jesper Horn Pedersen

Mail: [jehp@arteliagroup.dk](mailto:jehp@arteliagroup.dk)

Company: Artelia Energy, Artelia A/S, Denmark

Master thesis: X

# Wave-Induced Loads on Airtight Platforms in Offshore Wind Monopiles

## The Challenge

When waves cause an oscillating water level inside a monopile, the trapped air between the water surface and the airtight platform (ATP) is compressed and decompressed. This air compressibility creates significant loads on the ATP, which simplified models often fail to capture accurately.

## Your Project

You will make a real-world impact by combining theoretical modelling with advanced simulation techniques:

- Model Development: Expand an existing engineering model to account for the second-order effects of waves and directionality of the water flow into the monopile.
- Validation: Use Computational Fluid Dynamics (CFD) to validate your enhanced model and ensure its accuracy.
- Sensitivity Analysis: Analyse how design choices, such as water replenishment holes, ATP elevation, and wave characteristics affect the magnitude of the pressure loads.

## Student Profile

- Background in civil, offshore, or mechanical engineering
- Familiarity with wave mechanics and numerical methods.
- Interest in CFD (previous experience beneficial but not mandatory).

This is an excellent opportunity to gain hands-on expertise in hydrodynamic modelling while contributing to the future of sustainable energy within industry. 

# MASTER THESIS PROJECT TITLE

## Keywords:

Wave-Induced Pressure Loads, Monopile Foundations, CFD

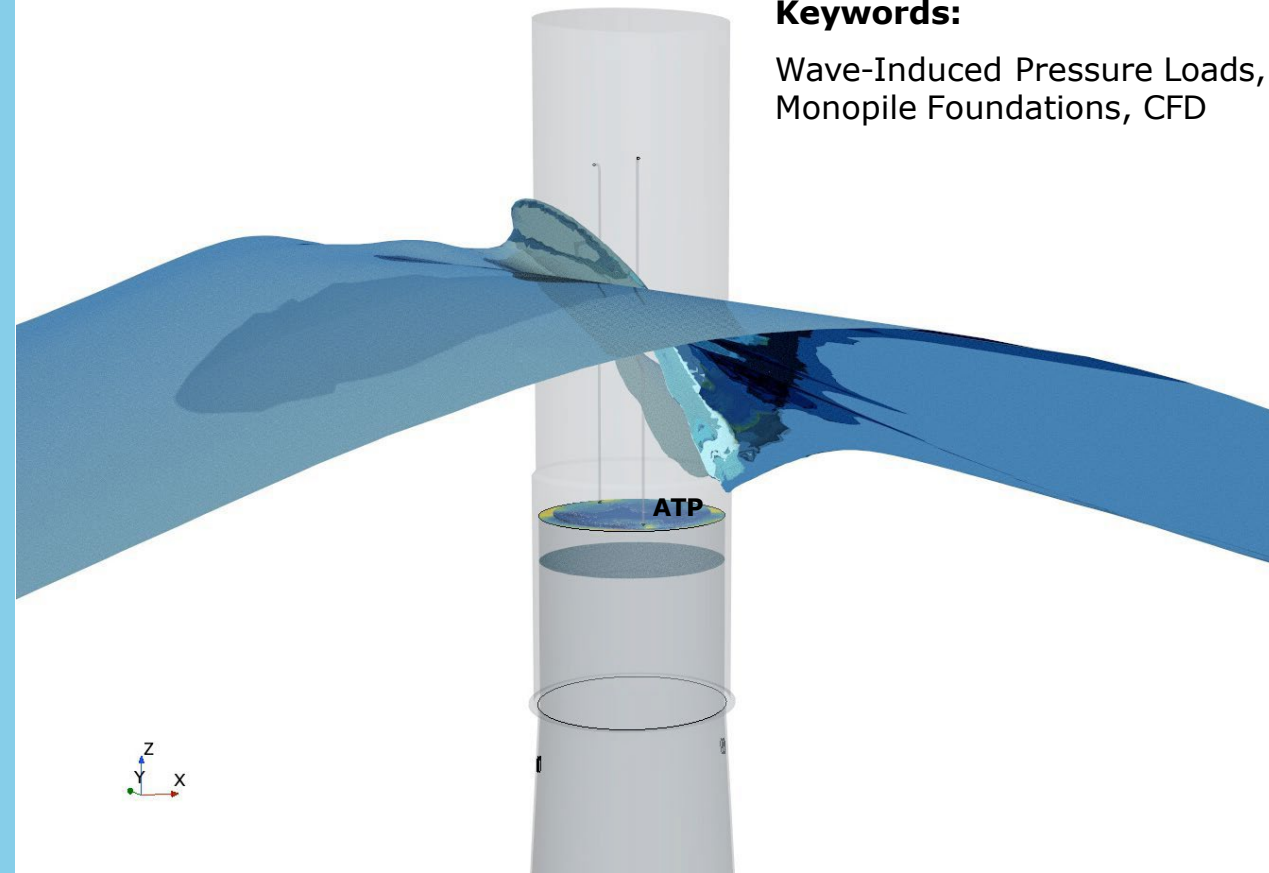

## Contact & Information

Contact person: Aref Moalemi

Mail: [armo@ramboll.dk](mailto:armo@ramboll.dk)

Division/Company: Advanced Numerical Simulations/ Ramboll

Master thesis: X

Expected start date: Fall 2026

# Investigating Chinese Offshore Wind Installation and O&M

Short description of the thesis/project idea (include an illustration if relevant)

China is the world's largest offshore wind market, yet detailed insights into its installation and operation & maintenance (O&M) performance remain scarce. This thesis aims to investigate the Chinese offshore wind market using Sea Impact's data-driven methodology, combining vessel position (AIS) data, satellite imagery, and publicly available project information to uncover patterns in installation methods, vessel utilization, and O&M practices.

The work will involve analyzing large datasets of Chinese offshore wind vessel activity, enriching these with public and industry data sources, and benchmarking findings against European offshore wind projects. The outcome will provide valuable perspectives on the performance, efficiency, and characteristics of the relatively closed Chinese offshore wind market.

## Keywords

Offshore Wind · Installation · Operation & Maintenance · Data Analysis

## Contact & Information

Contact person: Lars-André Bugge  
Tobaben

Mail: [lat@sea-impact.com](mailto:lat@sea-impact.com) Company:  
Sea Impact ApS Master thesis: X  
Bachelor project: X  
Can be both: X

# Design and Analysis of 3D concrete printed offshore structures

Sperra (sperra.com) is building a new foundation for renewable energy. We design and manufacture 3D concrete printed (3DCP) infrastructure for offshore wind, floating solar and wave energy projects. Using automated design and construction, we enable local teams to manufacture custom anchoring solutions using local materials. Our approach minimizes material waste, reduces carbon emissions and ensures more resilient infrastructure for clean energy to power this generation and the next. We are looking to work with MS students on aspects of engineering, design and analysis across technologies in our growing product portfolio such as:

- Station-keeping systems for floating offshore solar PV
- Coastal resilience structures
- Platforms for offshore RE-powered data centers

And more!

*Rendering of one of Sperra's 3DCP gravity anchors*



## Keywords:

Design

Optimization

Offshore structures

3D Concrete Printing

Multi-physics modelling

## Contact & Information

Contact person: Katherine Dykes

Mail: [Katherine.dykes@sperra.com](mailto:Katherine.dykes@sperra.com)

Company: Sperra

Master thesis: X

# Analysis and optimization of offshore renewable energy projects

Sperra ([sperra.com](http://sperra.com)) is building a new foundation for renewable energy. We design and manufacture 3D concrete printed (3DCP) infrastructure for offshore wind, floating solar and wave energy projects and more. We have several technologies to explore hybridization of offshore renewable energy projects – integrating offshore wind with floating offshore solar, long-duration subsea storage, battery technologies and more. We envision these facilities will be serve a variety of offtake:

- Traditional grid interconnection and energy markets
- Power-to-x for hydrogen
- RE-powered offshore data centers

We are looking to work with students on modelling of the sizing and operation (energy management) of these hybrid power plant systems for different applications.

*Rendering of a RE-Powered floating offshore data center system co-located with wind and solar*

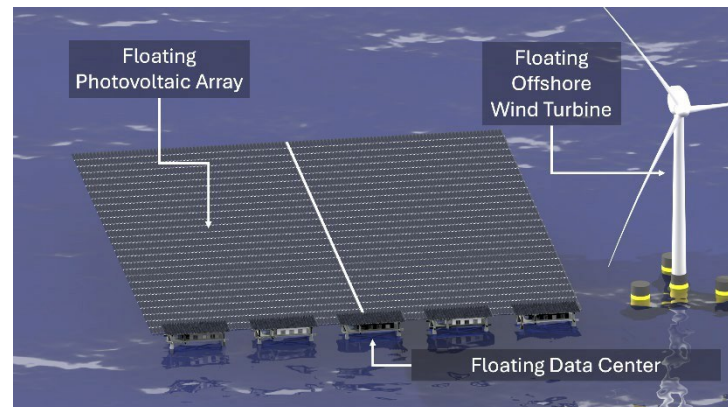

## Keywords:

Design

Optimization

Offshore renewables

Hybrid power plants

## Contact & Information

Contact person: Katherine Dykes

Mail: [Katherine.dykes@sperra.com](mailto:Katherine.dykes@sperra.com)

Company: Sperra

Master thesis: X

# Techno-economic and impact analysis for offshore renewables

Sperra (sperra.com) is building a new foundation for renewable energy. We design and manufacture 3D concrete printed (3DCP) infrastructure for offshore wind, floating solar and wave energy projects and more. We have several technologies in development for increasing cost-competitiveness and accelerating build-out of offshore renewable energy. Sperra's approach to construction and deployment of offshore wind and storage vertically-integrates supply chain in a novel way – combining development of port facilities, construction/manufacturing operations, and marine logistics. Using concrete in an ultra-efficient way, the technologies can also reduce environmental impacts (e.g. carbon emissions). We are looking to work with students on techno-economic analysis of these systems including:

- Levelized cost of energy / storage of novel offshore wind / storage systems
- Supply chain analysis
- Life cycle assessment

*Rendering of an integrated port facility, construction, logistics system for offshore wind*



## Keywords:

Offshore renewables  
Techno-economic analysis  
Supply chain analysis  
Life cycle assessment

## Contact & Information

Contact person: Katherine Dykes  
Mail: [Katherine.dykes@sperra.com](mailto:Katherine.dykes@sperra.com)  
Company: Sperra  
Master thesis: X

# Modal analysis - Quick tool for integrated load assessment

The usual process of conducting an integrated load analysis on offshore wind turbines requires the use of a hydro-aeroelastic BEM solver such as HAWC2. This procedure is time consuming and can be a bottleneck on commercial project work. The usual solution is to employ a frequency domain tool; however, this tool often fails to properly capture the wind-wave misalignment and the directional damping produced by the spinning rotor.

This thesis suggests to develop a modal analysis tool using a few Eigenmode-shapes to be run in the time domain. This tool can quickly assess the loading on a site given a wide range of site conditions. These site conditions are usually a predetermined statistical representations of the site, that does not account for which conditions are needed to appropriately represent the loading.

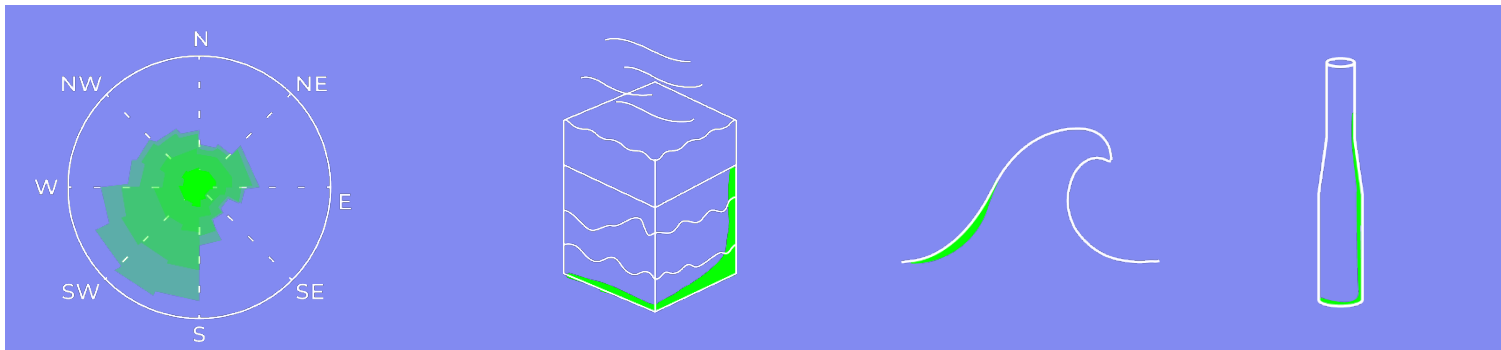

## Keywords

Modal analysis, integrated load analysis (ILA), BEM, eigenmode assessment, FLS, ULS, load case table (LCT), fast tool, time domain, site condition assessment, Wood Thilsted



## Contact & Information

Contact person: Martin Bjerre Nielsen

Mail: [mbn@woodthilsted.com](mailto:mbn@woodthilsted.com)

Company: Wood Thilsted

Master thesis: X

# Using soil hysteresis model resonant sea state

As turbines grow larger the effect of the non-linearity becomes more dominant, it is important that this is appropriately captured when modelling these large turbines. Here the hysteresis model is proving promising.

The thesis will consider an application of soil hysteresis modelling to a wide range of sea-states including: Normal sea-states for fatigue, severe sea-state, extreme sea state and extreme resonant sea state. The goal is to quantify the difference between the regular linear soil modelling approach to an integrated hysteresis soil response.

## Keywords

Resonant sea state (RSS), hysteresis, HAWC2, integrated load analysis (ILA), Wood Thilsted

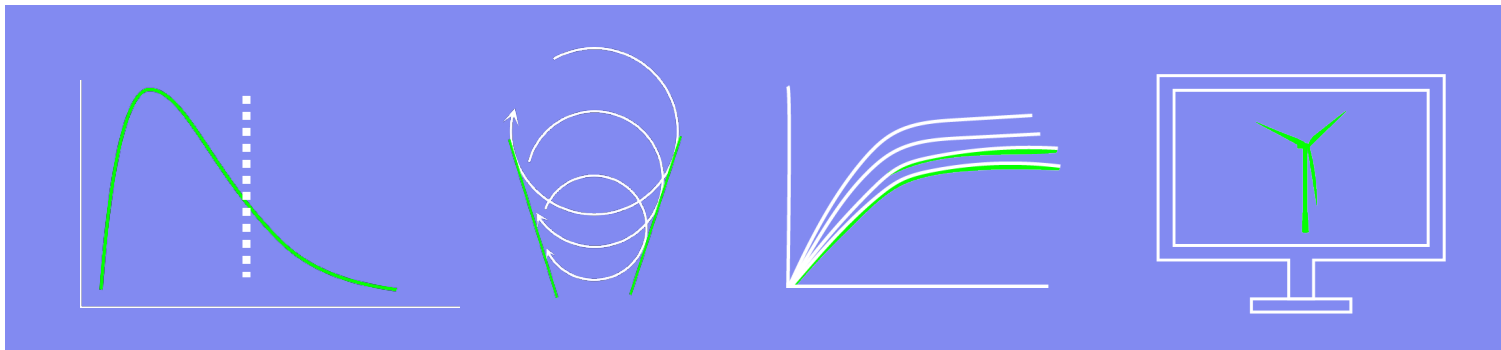

## Contact & Information

Contact person: Martin Bjerre Nielsen

Mail: [mbn@woodthilsted.com](mailto:mbn@woodthilsted.com)

Company: Wood Thilsted

Master thesis: X

# Novel foundation type modelling in Orcaflex

This topic covers a novel foundation type that is a fixed-bottom guyed supporting structure. The introduction of mooring line to this foundation type introduces new loading scenarios which include; Un-even mooring line tensioning and mooring line breaking. These load scenarios are of a complex nature that changes the dynamic response of the structure after their occurrence.

This study suggests investigating different type of mooring line complications and how to model these appropriately. The tools Orcaflex and HAWC2 are suggested to be integrated to fully capture the complex mechanics.

## Keywords

Orcaflex, floater, monopile, mooring line failure, novel foundation type, HAWC2, Wood Thilsted

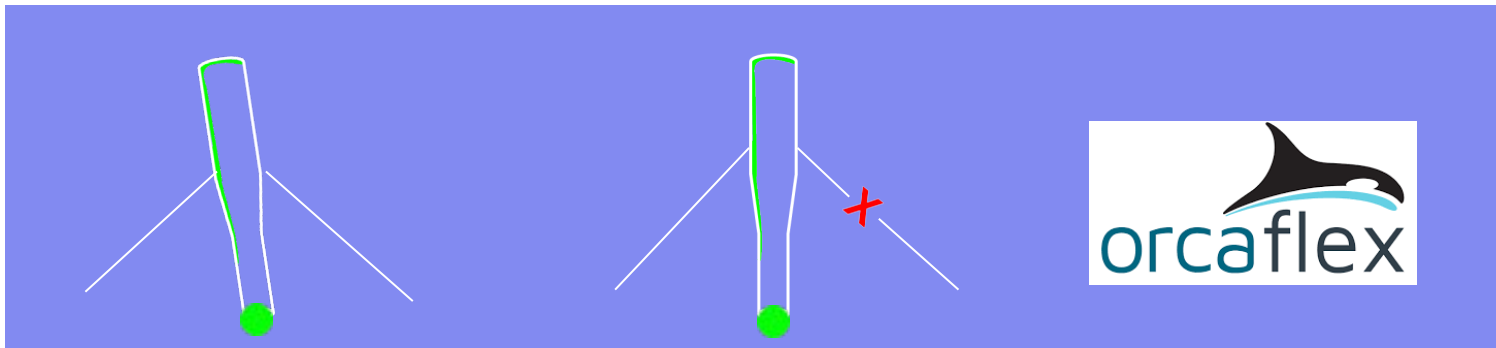

## Contact & Information

Contact person: Joshua Forrest  
Mail: [jfo@woodthilsted.com](mailto:jfo@woodthilsted.com)  
Company: Wood Thilsted  
Master thesis: X

# IEA reference turbine controller tuning in transient load events

The IEA 15MW reference turbine is the most advanced turbine model available. The commercial development has introduced loading scenarios that are not fully captured with the generic controller model.

This thesis suggests to expand the operational zones to above the default cut-out wind speed and introduce a tapered power output in-line with the latest commercial developments. The impact on this expansion of the operational zone on fatigue and ultimate limit states are to be assessed.

## Keywords

IEA reference turbine, turbine modelling, controller, cut-in, cut-out, ULS, FLS, Wood Thilsted

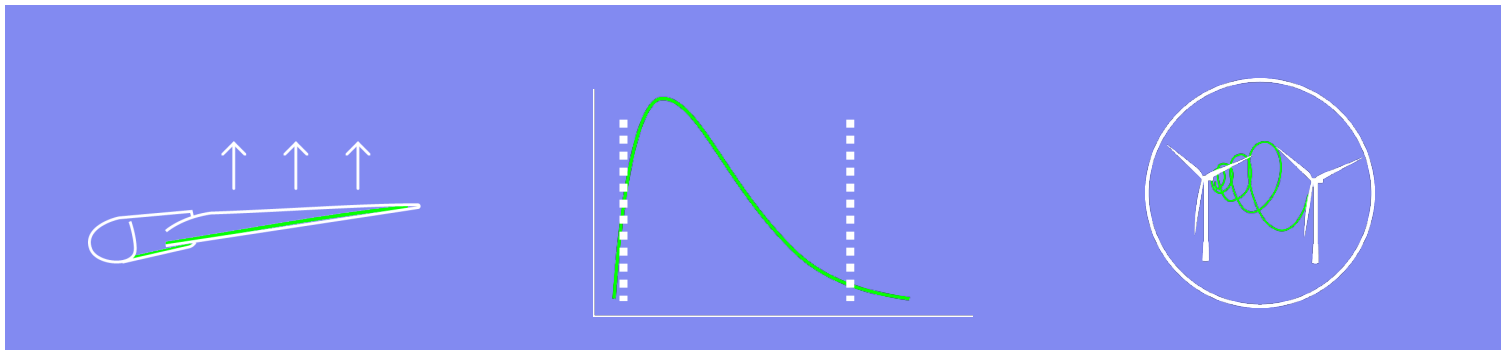

## Contact & Information

Contact person: Joshua Forrest

Mail: [jfo@woodthilsted.com](mailto:jfo@woodthilsted.com)

Company: Wood Thilsted

Master thesis: X